

# THE HYDRAULIC HAND BOOK

**EIGHTH EDITION**



## HIRSCH HYDRAULIC SERVICES



Unit 15, South Cape Industrial Park, 19 Leo Road, Diep River, Cape Town 7800

P.O. Box 334, Bergvliet 7864

Tel: (021) 706 7573

Cell: 0827287796 / 0833737556

Email: [sales@hirschyd.co.za](mailto:sales@hirschyd.co.za)

[www.hirschhydraulics.co.za](http://www.hirschhydraulics.co.za)



# THE HYDRAULIC HAND BOOK



EIGHTH EDITION

01-10-2022

CODE	CONTENTS	PAGE
60H-	HYDRAULIC VALVE MONOBLOCK	A 1 - A 4
61H-	HYDRAULIC VALVE PV4 & STACK	B 1 - B 7
62H-	HYDRAULIC VALVE SOLENOID & MANIFOLDS	C 1 - C 4
63H-	HYDRAULIC COMPONENTS	D 1 - D 10
64H-	HYDRAULIC HAND PUMPS	E 1 - E 2
65H-	HYDRAULIC HEAT EXCHANGERS & ACCUMULATORS	F 1 - F 2
66H-	HYDRAULIC TANKS, ACCESSORIES & GAUGES	G 1 - G 3
67H-	HYDRAULIC FILTERS	H 1 - H 2
68H-	HYDRAULIC PUMP COUPLINGS	I 1 - I 3
69H-	HYDRAULIC PUMP BELLHOUSINGS	J 1 - J 2
70H-	HYDRAULIC PUMPS / MOTORS ALUMINIUM GROUP 1 & 2	K 1 - K 8
71H-	HYDRAULIC PUMPS / MOTORS ALUMINIUM GROUP 3	L 1 - L 2
72H-	HYDRAULIC GEAR FLOW DIVIDERS & HI - LO PUMPS	M 1 - M 3
73H-	HYDRAULIC PUMPS O.E.M. & MINI POWER PACKS	N 1
74H-	HYDRAULIC PUMPS FORKLIFT	O 1 - O 6
75H-	HYDRAULIC PUMPS CAST IRON	P 1 - P 9
76H-	HYDRAULIC PUMPS P.T.O. PISTON & GEAR	Q 1 - Q 6
77H-	HYDRAULIC PUMPS VANE TYPE	R 1 - R 6
78H-	HYDRAULIC PUMPS PISTON	S 1 - S 10
79H- / 84H-	HYDRAULIC MOTORS & WINCHES	T 1 - T 7
80H-	HYDRAULIC STEERING UNITS	U 1 - U 2
81H-	HYDRAULIC CYLINDER TIE ROD TYPE & WELDED TYPE	V 1 - V 9
82H-	HYDRAULIC CYLINDER TIPPING & LOG SPLITTER TYPE	W 1
83H-	HYDRAULIC TECHNICAL INFORMATION	X 1 - X 6

**DISCLAIMER MESSAGE:**

PLEASE NOTE: ALL O.E.M. NAMES OR NUMBERS ARE FOR REFERENCE USE ONLY, HIRSCH HYDRAULICS CANNOT BE HELD RESPONSIBLE FOR THE USE OF ANY OF THE INFORMATION

DISCLOSED IN THIS CATALOGUE. THIS INFORMATION IS USED AT THE READERS DISCRETION. MANUFACTURERS NAMES, PART NUMBERS AND DESCRIPTIONS ARE FOR REFERENCE

PURPOSES ONLY. THIS DOES NOT IMPLY THAT ANY PARTS LISTED IS THE PRODUCT OF THESE MANUFACTURERS.

Part Number	<b>VALVES MONOBLOCK</b>		RETAIL:
			01-10-2022
	<u><b>MB - 3 - TAK - BOK SERIES</b></u>		
	( 45 LITRES FLOW RATE ALL PORTS 3/8" & 1/2" UP TO 3 BANK )		
60H-MB-3-1-3-8	MB - 3 / 1 S - 3 / 1 8 L / G - 3 / M 3	ONE SPOOL	3/8"
60H-MB-3-2-3-8	MB - 3 / 2 S - 3 / 1 8 L / G - 3 / M 3	TWO SPOOL	3/8"
60H-MB-3-3-3-8	MB - 3 / 3 S - 3 / 1 8 L / G - 3 / M 3	THREE SPOOL	3/8"
60H-MB-3-4-3-8	MB - 3 / 4 S - 3 / 1 8 L / G - 3 / M 3	FOUR SPOOL	3/8"
60H-MB-3-5-3-8	MB - 3 / 5 S - 3 / 1 8 L / G - 3 / M 3	FIVE SPOOL	3/8"
60H-MB-3-6-3-8	MB - 3 / 6 S - 3 / 1 8 L / G - 3 / M 3	SIX SPOOL	3/8"
	<u><b>SPOOL TYPE</b></u>		
60H-YLMB33001	SPOOL DOUBLE ACTING ON PORT ( A & B ) ( SPOOL TYPE 1 )		
60H-YLMB33002	SPOOL MOTOR ACTING ON PORT ( A & B ) ( SPOOL TYPE 2 )		
60H-YLMB33003	SPOOL SINGLE ACTING ON PORT ( A ) ( SPOOL TYPE 3 ) ( SPOOL OUT ) LEVER IN		
	<u><b>SPOOL CONTROL</b></u>		
60H-YLMB44061	3 POSITION DETENT	KIT TYPE ( 6-1 )	
60H-YLMB44092	1 POSITION DETENT	KIT TYPE ( 9-2 ) DETENT IN PORT B WITH SPRING CENTRED	
60H-YLMB44093	1 POSITION DETENT	KIT TYPE ( 9-3 ) DETENT IN PORT A WITH SPRING CENTRED	
60H-YLMB44080	PNEUMATIC CONTROL	KIT TYPE ( 8P )	
60H-YLMB48EP3	ELECTRO PNEUMATIC CONTROL KIT TYPE ( 8EP3 ) 12 OR 24 VOLT ( TO BE ADDED TO ABOVE )		
60H-YLMB45002	JOYSTICK	KIT TYPE ( LCB )	
60H-YLMB44200	DUAL CONTROL	KIT TYPE ( 8D2 )	
	<u><b>ACCESSORIES</b></u>		
60H-YLMB45000	LEVER BOX	KIT TYPE ( L )	
60H-YLMB34007	LEVER BOX	KIT TYPE ( 7 L ) NYLON	
60H-YLMB44008	END CAP	KIT TYPE ( 8 )	
60H-YLMB35000	END CAP	KIT TYPE ( 7 ) NYLON	
60H-YLMB35001	DUST CAP	KIT TYPE ( SPL )	
60H-YLMB08160	LEVER	KIT TYPE ( YL02M8X160 )	
60H-YLMB32003	RELIEF VALVE CARTRIDGE	TYPE ( DG-3 ) RANGE 63 - 200 BAR	
60H-YLMB32002S	RELIEF VALVE SPRING	KIT TYPE ( DG-2 ) RANGE 40 - 80 BAR	
60H-YLMB32003S	RELIEF VALVE SPRING	KIT TYPE ( DG-3 ) RANGE 63 - 200 BAR	
60H-YLMB32004S	RELIEF VALVE SPRING	KIT TYPE ( DG-4 ) RANGE 160 - 315 BAR	
60H-YLMB354121	DUMP VALVE NORMALY CLOSED - G03 - 12V DC ( NC ) - 2TXV018		
	<u><b>TECHNICAL SPECIFICATIONS</b></u>		
	<u><b>THREADS AND SIZES:</b></u>		
	A - PORT ON TOP	3/8" BSPP	
	B - PORT ON TOP	3/8" BSPP	
	P - PORT ON TOP	3/8" BSPP	
	T - PORT ON TOP	3/8" BSPP	
	C/O - PORT ON SIDE	3/8" BSPP	
	<u><b>RECOMMENDED FLOW RATE:</b></u>		
	45 LITRES PER MIN.		
	<u><b>PRESET OPERATING PRESSURE:</b></u>		
	120 BAR		
	<u><b>MAXIMUM OPERATING PRESSURE:</b></u>		
	315 BAR		
	<u><b>TANK LINE PRESSURE:</b></u>		
	25 BAR		
	<u><b>PORT IDENTIFICATION</b></u>		
	PORT ( A ) CLOSEST TO SPRING		
	PORT ( B ) CLOSEST TO LEVER		
			
PLEASE NOTE: ALL O.E.M. NAMES OR NUMBERS ARE FOR REFERENCE USE ONLY			PAGE A 1

<u>Part Number</u>	<b>VALVES MONOBLOCK</b>		RETAIL:
			01-10-2022
	<b><u>MB - 4 - TAK - BOK SERIES</u></b>		
	<b>( 60 LITRES FLOW RATE 1/2" PORTS )</b>		
60H-MB-4-1-1-2	MB - 4 / 1 - S - 3 / 18 L / G - 4 / M 3	ONE SPOOL	
60H-MB-4-2-1-2	MB - 4 / 2 - S - 3 / 18 L / G - 4 / M 3	TWO SPOOL	
60H-MB-4-3-1-2	MB - 4 / 3 - S - 3 / 18 L / G - 4 / M 3	THREE SPOOL	
60H-MB-4-4-1-2	MB - 4 / 4 - S - 3 / 18 L / G - 4 / M 3	FOUR SPOOL	
60H-MB-4-5-1-2	MB - 4 / 5 - S - 3 / 18 L / G - 4 / M 3	FIVE SPOOL	
60H-MB-4-6-1-2	MB - 4 / 6 - S - 3 / 18 L / G - 4 / M 3	SIX SPOOL	
	<b><u>SPOOL TYPE</u></b>		
60H-YLMB43001	SPOOL DOUBLE ACTING ON PORT ( A & B ) ( SPOOL TYPE 1 )		
60H-YLMB43002	SPOOL MOTOR ACTING ON PORT ( A & B ) ( SPOOL TYPE 2 )		
60H-YLMB43003	SPOOL SINGLE ACTING ON PORT ( A ) ( SPOOL TYPE 3 ) ( SPOOL IN ) LEVER OUT		
60H-YLMB43004	SPOOL SINGLE ACTING ON PORT ( B ) ( SPOOL TYPE 4 ) ( SPOOL OUT ) LEVER IN		
	<b><u>SPOOL CONTROL</u></b>		
60H-YLMB44061	3 POSITION DETENT KIT TYPE ( 6-1 )		
60H-YLMB44092	1 POSITION DETENT KIT TYPE ( 9-2 ) DETENT IN PORT B WITH SPRING CENTRED		
60H-YLMB44093	1 POSITION DETENT KIT TYPE ( 9-3 ) DETENT IN PORT A WITH SPRING CENTRED		
60H-YLMB44080	PNEUMATIC CONTROL KIT TYPE ( 8P )		
60H-YLMB48EP3	ELECTRO PNEUMATIC CONTROL KIT TYPE ( 8EP3 ) 12 OR 24 VOLT ( TO BE ADDED TO ABOVE )		
60H-YLMB45002	JOYSTICK KIT TYPE ( LCB )		
60H-YLMB44200	DUAL CONTROL KIT TYPE ( 8D2 )		
	<b><u>ACCESSORIES</u></b>		
60H-YLMB45000	LEVER BOX KIT TYPE ( L )		
60H-YLMB34007	LEVER BOX KIT TYPE ( 7 L ) NYLON		
60H-YLMB44008	END CAP KIT TYPE ( 8 )		
60H-YLMB35000	END CAP KIT TYPE ( 7 ) NYLON		
60H-YLMB45001	DUST CAP KIT TYPE ( SPL )		
60H-YLMB08160	LEVER KIT TYPE ( YLO2M8X160 )		
60H-YLMB42003	RELIEF VALVE CARTRIDGE TYPE ( MG-3 ) RANGE 63 - 200 BAR		
60H-YLMB42002S	RELIEF VALVE SPRING KIT TYPE ( MG-2 ) RANGE 40 - 80 BAR		
60H-YLMB42003S	RELIEF VALVE SPRING KIT TYPE ( MG-3 ) RANGE 63 - 200 BAR		
60H-YLMB42004S	RELIEF VALVE SPRING KIT TYPE ( MG-4 ) RANGE 160 - 315 BAR		
60H-YLMB454121	DUMP - G04 - 12V DC (NC) - 2TXV021		
	<b><u>TECHNICAL SPECIFICATIONS</u></b>		
	<b><u>THREADS AND SIZES:</u></b>		
	A - PORT ON TOP	1/2" BSPP	
	B - PORT ON TOP	1/2" BSPP	
	P - PORT ON TOP	1/2" BSPP	
	T - PORT ON TOP	1/2" BSPP	
	C/O - PORT ON SIDE	1/2" BSPP	
	<b><u>RECOMMENDED FLOW RATE:</u></b>		
	60 LITRES PER MIN.		
	<b><u>PRESET OPERATING PRESSURE:</u></b>		
	120 BAR		
	<b><u>MAXIMUM OPERATING PRESSURE:</u></b>		
	315 BAR		
	<b><u>TANK LINE PRESSURE:</u></b>		
	25 BAR		
	<b><u>PORT IDENTIFICATION</u></b>		
	PORT ( B ) CLOSEST TO SPRING		
	PORT ( A ) CLOSEST TO LEVER		
			
	<b>PLEASE NOTE: ALL O.E.M. NAMES OR NUMBERS ARE FOR REFERENCE USE ONLY</b>		<b>PAGE A 2</b>

Part Number	<b>VALVES MONOBLOCK</b>		RETAIL:	
			<b>01-10-2022</b>	
	<b><u>MB - 4 - TAK - BOK SERIES</u> SOLENOID OPERATED ONLY</b>			
	<b>(35 LITRES FLOW RATE 140 BAR 1/2" PORTS)</b>			
60H-MB-4-1-DC	MB - 4 / 1 S - 3 / 1 8 E S 3 / G - 4 / M 3	ONE SPOOL		
60H-MB-4-2-DC	MB - 4 / 2 S - 3 / 1 8 E S 3 / G - 4 / M 3	TWO SPOOL		
60H-MB-4-3-DC	MB - 4 / 3 S - 3 / 1 8 E S 3 / G - 4 / M 3	THREE SPOOL		
60H-MB-4-4-DC	MB - 4 / 4 S - 3 / 1 8 E S 3 / G - 4 / M 3	FOUR SPOOL		
60H-MB-4-5-DC	MB - 4 / 5 S - 3 / 1 8 E S 3 / G - 4 / M 3	FIVE SPOOL		
60H-MB-4-6-DC	MB - 4 / 6 S - 3 / 1 8 E S 3 / G - 4 / M 3	SIX SPOOL		
	<b><u>SPOOL CONTROL</u></b>			
60H-YLMB44511	3 POSITION DOUBLE ACTING SOLENOID CONTROL KIT TYPE ( 1 8 ES3 ) 12 VOLT DC			
60H-YLMB44521	3 POSITION MOTOR ACTING SOLENOID CONTROL KIT TYPE ( 2 8 ES3 ) 12 VOLT DC			
60H-YLMB44512	3 POSITION DOUBLE ACTING SOLENOID CONTROL KIT TYPE ( 1 8 ES3 ) 24 VOLT DC			
60H-YLMB44522	3 POSITION MOTOR ACTING SOLENOID CONTROL KIT TYPE ( 2 8 ES3 ) 24 VOLT DC			
	<b><u>SPOOL CONTROL</u></b>			
60H-YLMB44511	SOLENOID DIRECT CONTROL KIT TYPE ( 8ES3 ) 12 VOLT DC			
60H-YLMB44512	SOLENOID DIRECT CONTROL KIT TYPE ( 8ES3 ) 24 VOLT DC			
	<b><u>ACCESSORIES</u></b>			
60H-YLMB8ES12D	SOLENOID ONLY FOR KIT TYPE ( 8ES3 ) 12 VOLT DC			
60H-YLMB8ES24D	SOLENOID ONLY FOR KIT TYPE ( 8ES3 ) 24 VOLT DC			
60H-YLMB42002S	RELIEF VALVE SPRING KIT TYPE ( MG-2 ) RANGE 40 - 80 BAR			
60H-YLMB42003S	RELIEF VALVE SPRING KIT TYPE ( MG-3 ) RANGE 63 - 200 BAR			
60H-YLMB42004S	RELIEF VALVE SPRING KIT TYPE ( MG-4 ) RANGE 160 - 315 BAR			
60H-YLMB454121	DUMP - G04 - 12V DC (NC) - 2TXV021			
	<b><u>TECHNICAL SPECIFICATIONS</u></b>			
	<b><u>THREADS AND SIZES:</u></b>			
	A - PORT ON TOP	1/2" BSPP		
	B - PORT ON TOP	1/2" BSPP		
	P - PORT ON TOP	1/2" BSPP		
	T - PORT ON TOP	1/2" BSPP		
	C/O - PORT ON SIDE	1/2" BSPP		
	<b><u>RECOMMENDED FLOW RATE:</u></b>			
	35 LITRES PER MIN.			
	<b><u>PRESET OPERATING PRESSURE:</u></b>			
	120 BAR			
	<b><u>MAXIMUM OPERATING PRESSURE:</u></b>			
	140 BAR			
	<b><u>TANK LINE PRESSURE:</u></b>			
	25 BAR			
	<b><u>PORT IDENTIFICATION</u></b>			
	PORT ( B ) CLOSEST TO SPRING			
	PORT ( A ) CLOSEST TO LEVER			
<b>PLEASE NOTE: ALL O.E.M. NAMES OR NUMBERS ARE FOR REFERENCE USE ONLY</b>				<b>PAGE A 3</b>



Part Number	VALVES MONOBLOCK		RETAIL:
			01-10-2022
	<b><u>MB - 5 - TAK - BOK SERIES</u></b>		
	<b>(90 LITRES FLOW RATE 1/2" PORTS)</b>		
60H-MB-5-1-1-2	MB - 5 / 1 S - 3 / 1 8 L / G - 4 - 6 / M 3	ONE SPOOL	
60H-MB-5-2-1-2	MB - 5 / 2 S - 3 / 1 8 L / G - 4 - 6 / M 3	TWO SPOOL	
60H-MB-5-3-1-2	MB - 5 / 3 S - 3 / 1 8 L / G - 4 - 6 / M 3	THREE SPOOL	
60H-MB-5-4-1-2	MB - 5 / 4 S - 3 / 1 8 L / G - 4 - 6 / M 3	FOUR SPOOL	
60H-MB-5-5-1-2	MB - 5 / 5 S - 3 / 1 8 L / G - 4 - 6 / M 3	FIVE SPOOL	
60H-MB-5-6-1-2	MB - 5 / 6 S - 3 / 1 8 L / G - 4 - 6 / M 3	SIX SPOOL	
	<b><u>POSSIBLE OPTIONS</u></b>		
60H-YLMB5COPG6	POWER BEYOND <b>POSSIBLE</b> ; USE POWER BEYOND SLEEVE		
60H-4B-08	CLOSED CENTER <b>POSSIBLE</b> ; USE ABOVE & 1/2" BSPP HEX ADAPTOR & WASHER		
	<b><u>SPOOL TYPE</u></b>		
60H-YLMB53001	SPOOL DOUBLE ACTING ON PORT ( A & B ) ( SPOOL TYPE 1 )		
60H-YLMB53002	SPOOL MOTOR ACTING ON PORT ( A & B ) ( SPOOL TYPE 2 )		
60H-YLMB53003	SPOOL SINGLE ACTING ON PORT ( A ) ( SPOOL TYPE 3 ) ( SPOOL IN ) LEVER OUT		
60H-YLMB53004	SPOOL SINGLE ACTING ON PORT ( B ) ( SPOOL TYPE 4 ) ( SPOOL OUT ) LEVER IN		
	<b><u>SPOOL CONTROL</u></b>		
60H-YLMB54061	3 POSITION DETENT KIT TYPE ( 6-1 )		
60H-YLMB54092	1 POSITION DETENT KIT TYPE ( 9-2 ) DETENT IN PORT B WITH SPRING CENTRED		
60H-YLMB54093	1 POSITION DETENT KIT TYPE ( 9-3 ) DETENT IN PORT A WITH SPRING CENTRED		
60H-YLMB54080	PNEUMATIC CONTROL KIT TYPE ( 8P )		
60H-YLMB58EP3	ELECTRO PNEUMATIC CONTROL KIT TYPE ( 8EP3 ) 12 OR 24 VOLT ( TO BE ADDED TO ABOVE )		
60H-YLMB55002	JOYSTICK KIT TYPE ( LCB )		
60H-YLMB54082	DUAL CONTROL KIT TYPE ( 8D2 )		
60H-MB5-1DRHL	ROTARY DETENT KIT TYPE PLUS LEVER		
	<b><u>ACCESSORIES</u></b>		
60H-YLMB55000	LEVER BOX KIT TYPE ( L )		
60H-YLMB54008	END CAP KIT TYPE ( 8 )		
60H-YLMB55001	DUST CAP KIT TYPE ( SPL )		
60H-YLMB10200	LEVER KIT TYPE ( YLO1M10X200 )		
60H-YLMB52003	RELIEF VALVE CARTRIDGE TYPE ( AG-3 ) RANGE 125 - 250 BAR		
60H-YLMB52002S	RELIEF VALVE SPRING KIT TYPE ( DG-2 ) RANGE 80 - 160 BAR		
60H-YLMB52003S	RELIEF VALVE SPRING KIT TYPE ( DG-3 ) RANGE 125 - 250 BAR		
60H-YLMB52004S	RELIEF VALVE SPRING KIT TYPE ( DG-4 ) RANGE 200 - 315 BAR		
	<b><u>TECHNICAL SPECIFICATIONS</u></b>		
	<b><u>THREADS AND SIZES:</u></b>		
	A - PORT ON TOP	1/2" BSPP	
	B - PORT ON TOP	1/2" BSPP	
	P - PORT ON TOP	1/2" BSPP	
	T - PORT ON TOP	3/4" BSPP	
	C/O - PORT ON SIDE	3/4" BSPP	
	<b><u>RECOMMENDED FLOW RATE:</u></b>		
	80 LITRES PER MIN.		
	<b><u>PRESET OPERATING PRESSURE:</u></b>		
	120 BAR		
	<b><u>MAXIMUM OPERATING PRESSURE:</u></b>		
	315 BAR		
	<b><u>TANK LINE PRESSURE:</u></b>		
	25 BAR		
	<b><u>PORT IDENTIFICATION</u></b>		
	PORT ( A ) CLOSEST TO SPRING		
	PORT ( B ) CLOSEST TO LEVER		
			
	<b>PLEASE NOTE: ALL O.E.M. NAMES OR NUMBERS ARE FOR REFERENCE USE ONLY</b>		<b>PAGE A 4</b>

<u>Part Number</u>	<b>VALVES STACK</b>		RETAIL: 01-10-2022
	<b><u>SN - 4 - TAK - BOK SERIES</u></b>		
	<b>( 80 LITRES FLOW RATE 1/2" PORTS )</b>		
61H-SN-4-1-1-2	SN - 4 / 1 S - 3 / 1 8 L / P 3 T / G - 4 - 6 / M 3	ONE SPOOL	
61H-SN-4-2-1-2	SN - 4 / 2 S - 3 / 1 8 L / P 3 T / G - 4 - 6 / M 3	TWO SPOOL	
61H-SN-4-3-1-2	SN - 4 / 3 S - 3 / 1 8 L / P 3 T / G - 4 - 6 / M 3	THREE SPOOL	
61H-SN-4-4-1-2	SN - 4 / 4 S - 3 / 1 8 L / P 3 T / G - 4 - 6 / M 3	FOUR SPOOL	
61H-SN-4-5-1-2	SN - 4 / 5 S - 3 / 1 8 L / P 3 T / G - 4 - 6 / M 3	FIVE SPOOL	
61H-SN-4-6-1-2	SN - 4 / 6 S - 3 / 1 8 L / P 3 T / G - 4 - 6 / M 3	SIX SPOOL	
61H-SN-4-7-1-2	SN - 4 / 7 S - 3 / 1 8 L / P 3 T / G - 4 - 6 / M 3	SEVEN SPOOL	
61H-SN-4-8-1-2	SN - 4 / 8 S - 3 / 1 8 L / P 3 T / G - 4 - 6 / M 3	EIGHT SPOOL	
61H-SN-4-9-1-2	SN - 4 / 9 S - 3 / 1 8 L / P 3 T / G - 4 - 6 / M 3	NINE SPOOL	
61H-SN-4-10-1-2	SN - 4 / 10 S - 3 / 1 8 L / P 3 T / G - 4 - 6 / M 3	TEN SPOOL	
61H-SN-4-11-1-2	SN - 4 / 11 S - 3 / 1 8 L / P 3 T / G - 4 - 6 / M 3	ELEVEN SPOOL	
61H-SN-4-12-1-2	SN - 4 / 12 S - 3 / 1 8 L / P 3 T / G - 4 - 6 / M 3	TWELVE SPOOL	
	<b><u>SPOOL TYPE</u></b>		
61H-YLWSN42001	SPOOL DOUBLE ACTING ON PORT ( A & B )	( SPOOL TYPE 1 )	
61H-YLWSN42002	SPOOL MOTOR ACTING ON PORT ( A & B )	( SPOOL TYPE 2 )	
61H-YLWSN42003	SPOOL SINGLE ACTING ON PORT ( A )	( SPOOL TYPE 3 ) ( SPOOL OUT ) LEVER IN	
61H-YLWSN42004	SPOOL SINGLE ACTING ON PORT ( B )	( SPOOL TYPE 4 ) ( SPOOL IN ) LEVER OUT	
61H-YLWSN45003	PORT RELIEF VALVES PER PORT P ( G3-100 ) RANGE 100 TO 250 BAR		
61H-YLWSN45004	PORT RELIEF VALVES PER PORT P ( G4-200 ) RANGE 200 TO 315 BAR		
	<b><u>SPOOL CONTROL</u></b>		
61H-YLWSN43061	3 POSITION DETENT KIT TYPE ( 6-1 )		
61H-YLWSN43092	1 POSITION DETENT KIT TYPE ( 9-2 ) DETENT IN PORT B WITH SPRING CENTRED		
61H-YLWSN43093	1 POSITION DETENT KIT TYPE ( 9-3 ) DETENT IN PORT A WITH SPRING CENTRED		
61H-YLWSN43080	PNEUMATIC CONTROL KIT TYPE ( 8P )		
61H-YLWSN48EP3	ELECTRO PNEUMATIC CONTROL KIT TYPE ( 8EP3 ) 12 OR 24 VOLT ( TO BE ADDED TO ABOVE )		
61H-YLWSN430810	HYDRAULIC PILOT CONTROL KIT TYPE ( 8IM )		
61H-JHP-1-1S-G2	HYDRAULIC PILOT JOY - STICK PER SECTION PILOT PRESSURE 2 - 20 Bar 1/4" Bsp PORTS		
61H-JHP-1-1S-FD	HYDRAULIC PILOT JOY - STICK FRICTION DETENT PILOT PRESSURE 2 - 20 Bar 1/4" Bsp PORTS		
61H-JHP-201-LCB	HYDRAULIC PILOT JOY - STICK 4 Way PILOT PRESSURE 2 - 20 Bar 1/4" Bsp PORTS		
61H-YLWSN44002	VALVE JOYSTICK KIT MANUAL TYPE ( LCB )		
61H-YLWSN43082	DUAL CONTROL KIT TYPE ( 8D2 )		
61H-SN4-1DRHL	ROTARY DETENT KIT TYPE PLUS LEVER		
	<b><u>ACCESSORIES</u></b>		
61H-YLWSN44000	LEVER BOX	KIT TYPE ( L )	
61H-YLWSN44001	DUST CAP	KIT TYPE ( SPL )	
61H-YLWSN43008	END CAP	KIT TYPE ( 8 )	
61H-YLWSN10200	LEVER	KIT TYPE ( YLO1M10X200 )	
61H-YLPSN43003	RELIEF VALVE CARTRIDGE TYPE ( DG-3 ) RANGE 125 - 250 BAR		
61H-YLPSN43002S	RELIEF VALVE SPRING KIT TYPE ( DG-2 ) RANGE 80 - 160 BAR		
61H-YLPSN43003S	RELIEF VALVE SPRING KIT TYPE ( DG-3 ) RANGE 125 - 250 BAR		
61H-YLPSN43004S	RELIEF VALVE SPRING KIT TYPE ( DG-4 ) RANGE 200 - 315 BAR		
61H-YLPEPCFSN4	PRESSURE COMPENSATED FLOW DIVIDER		
	<b><u>TECHNICAL SPECIFICATIONS:</u></b>		
	P - PORT	1/2" BSPP	
	A - PORT ( SPRING )	1/2" BSPP	
	B - PORT ( LEVER )	1/2" BSPP	
	T - PORT	3/4" BSPP	
	CO - PORT	3/4" BSPP	
	<b><u>RECOMMENDED FLOW RATE:</u></b>		
	80 LITRES PER MIN.		
	<b><u>MAX OPERATING PRESSURE:</u></b>		
	315 BAR		
	<b><u>PORT PRESSURE:</u></b>		
	315 BAR		
	<b><u>TANK LINE PRESSURE:</u></b>		
	25 BAR		
	PLEASE NOTE: ALL O.E.M. NAMES OR NUMBERS ARE FOR REFERENCE USE ONLY		







Part Number	<b>VALVES STACK</b>		RETAIL:
			01-10-2022
	<b><u>SN - 6 - TAK - BOK SERIES</u></b>		
	<b>( 150 LITRES FLOW RATE 3/4" PORTS )</b>		
61H-SN-6-1-3-4	SN - 6 / 1 S - 3 / 1 8 L / P3T / G - 6 - 1 / M 3	ONE SPOOL	
61H-SN-6-2-3-4	SN - 6 / 2 S - 3 / 1 8 L / P3T / G - 6 - 1 / M 3	TWO SPOOL	
61H-SN-6-3-3-4	SN - 6 / 3 S - 3 / 1 8 L / P3T / G - 6 - 1 / M 3	THREE SPOOL	
61H-SN-6-4-3-4	SN - 6 / 4 S - 3 / 1 8 L / P3T / G - 6 - 1 / M 3	FOUR SPOOL	
61H-SN-6-5-3-4	SN - 6 / 5 S - 3 / 1 8 L / P3T / G - 6 - 1 / M 3	FIVE SPOOL	
61H-SN-6-6-3-4	SN - 6 / 6 S - 3 / 1 8 L / P3T / G - 6 - 1 / M 3	SIX SPOOL	
61H-SN-6-7-3-4	SN - 6 / 7 S - 3 / 1 8 L / P3T / G - 6 - 1 / M 3	SEVEN SPOOL	
61H-SN-6-8-3-4	SN - 6 / 8 S - 3 / 1 8 L / P3T / G - 6 - 1 / M 3	EIGHT SPOOL	
	<b><u>SPOOL TYPE</u></b>		
61H-YLWSN62001	SPOOL DOUBLE ACTING ON PORT ( A & B )	( SPOOL TYPE 1 )	
61H-YLWSN62002	SPOOL MOTOR ACTING ON PORT ( A & B )	( SPOOL TYPE 2 )	
61H-YLWSN62003	SPOOL SINGLE ACTING ON PORT ( A )	( SPOOL TYPE 3 ) ( SPOOL OUT ) LEVER IN	
61H-YLWSN62004	SPOOL SINGLE ACTING ON PORT ( B )	( SPOOL TYPE 4 ) ( SPOOL IN ) LEVER OUT	
61H-YLWSN65003	PORT RELIEF VALVES PER PORT P ( G3-100 ) RANGE 100 TO 250 BAR		
61H-YLWSN65004	PORT RELIEF VALVES PER PORT P ( G4-200 ) RANGE 200 TO 315 BAR		
	<b><u>SPOOL CONTROL</u></b>		
61H-YLWSN63061	3 POSITION DETENT KIT TYPE ( 6-1 )		
61H-YLWSN63092	1 POSITION DETENT	KIT TYPE ( 9-2 ) DETENT IN PORT B WITH SPRING CENTRED	
61H-YLWSN63093	1 POSITION DETENT	KIT TYPE ( 9-3 ) DETENT IN PORT A WITH SPRING CENTRED	
61H-YLWSN63080	PNEUMATIC CONTROL KIT TYPE ( 8P )		
61H-YLWSN68EP3	ELECTRO PNEUMATIC CONTROL KIT TYPE ( 8EP3 ) 12 OR 24 VOLT ( TO BE ADDED TO ABOVE )		
61H-YLWSN630810	HYDRAULIC PILOT CONTROL KIT TYPE ( 8IM )		
61H-JHP-1-1S-G2	HYDRAULIC PILOT JOY - STICK PER SECTION PILOT PRESSURE 2 - 20 Bar 1/4" Bsp PORTS		
61H-JHP-1-1S-FD	HYDRAULIC PILOT JOY - STICK FRICTION DETENT PILOT PRESSURE 2 - 20 Bar 1/4" Bsp PORTS		
61H-JHP-201-LCB	HYDRAULIC PILOT JOY - STICK 4 WAY PILOT PRESSURE 2 - 20 Bar 1/4" Bsp PORTS		
61H-YLWSN64002	JOYSTICK	KIT TYPE ( LCB )	
61H-YLWSN63082	DUAL CONTROL	KIT TYPE ( 8D2 )	
61H-SN6-1DRHL	ROTARY DETENT	KIT TYPE PLUS LEVER	
	<b><u>ACCESSORIES</u></b>		
61H-YLWSN64000	LEVER BOX	KIT TYPE ( L )	
61H-YLWSN64001	DUST CAP	KIT TYPE ( SPL )	
61H-YLWSN63008	END CAP	KIT TYPE ( 8 )	
61H-YLWSN10200	LEVER	KIT TYPE ( YLO1M10X200 )	
61H-YLPSN63003	RELIEF VALVE CARTRIDGE	TYPE ( FG-3 ) RANGE 63 - 200 BAR	
61H-YLPSN63002S	RELIEF VALVE SPRING	KIT TYPE ( FG-3 ) RANGE 63 - 200 BAR	
61H-YLPSN63003S	RELIEF VALVE SPRING	KIT TYPE ( FG-4 ) RANGE 160 - 315 BAR	
61H-YLPSN63000	PILOT OPERATED RELIEF	KIT TYPE ( XFG ) RANGE 25 - 315 BAR	
61H-YLPEPCFSN6	PRESSURE COMPENSATED FLOW DIVIDER		
	<b><u>TECHNICAL SPECIFICATIONS:</u></b>		
	P - PORT	3/4" BSPP	
	A - PORT (SPRING)	3/4" BSPP	
	B - PORT (LEVER)	3/4" BSPP	
	T - PORT	1" BSPP	
	CO - PORT	1" BSPP	
	<b><u>RECOMMENDED FLOW RATE:</u></b>		
	150 LITRES PER MIN.		
	<b><u>MAX OPERATING PRESSURE:</u></b>		
	315 BAR		
	<b><u>PORT PRESSURE:</u></b>		
	315 BAR		
	<b><u>TANK LINE PRESSURE:</u></b>		
	25 BAR		
			
	<b>PLEASE NOTE: ALL O.E.M. NAMES OR NUMBERS ARE FOR REFERENCE USE ONLY</b>		



Part Number	<b>VALVES STACK</b>		RETAIL:
			01-10-2022
	<b><u>SN - 8 - TAK - BOK SERIES</u></b>		
	<b>( 250 LITRES FLOW RATE 1" PORTS )</b>		
61H-SN-8-1-1	SN - 8 / 1 S - XHG / 18 L / P3T / G - 8 - 10 / M 3	ONE SPOOL	
61H-SN-8-2-1	SN - 8 / 2 S - XHG / 18 L / P3T / G - 8 - 10 / M 3	TWO SPOOL	
61H-SN-8-3-1	SN - 8 / 3 S - XHG / 18 L / P3T / G - 8 - 10 / M 3	THREE SPOOL	
61H-SN-8-4-1	SN - 8 / 4 S - XHG / 18 L / P3T / G - 8 - 10 / M 3	FOUR SPOOL	
61H-SN-8-5-1	SN - 8 / 5 S - XHG / 18 L / P3T / G - 8 - 10 / M 3	FIVE SPOOL	
61H-SN-8-6-1	SN - 8 / 6 S - XHG / 18 L / P3T / G - 8 - 10 / M 3	SIX SPOOL	
61H-SN-8-7-1	SN - 8 / 7 S - XHG / 18 L / P3T / G - 8 - 10 / M 3	SEVEN SPOOL	
61H-SN-8-8-1	SN - 8 / 8 S - XHG / 18 L / P3T / G - 8 - 10 / M 3	EIGHT SPOOL	
	<b><u>SPOOL TYPE</u></b>		
61H-YLWSN82001	SPOOL DOUBLE ACTING ON PORT ( A & B )	( SPOOL TYPE 1 )	
61H-YLWSN82002	SPOOL MOTOR ACTING ON PORT ( A & B )	( SPOOL TYPE 2 )	
61H-YLWSN82003	SPOOL SINGLE ACTING ON PORT ( A )	( SPOOL TYPE 3 ) ( SPOOL OUT ) LEVER IN	
61H-YLWSN82004	SPOOL SINGLE ACTING ON PORT ( B )	( SPOOL TYPE 4 ) ( SPOOL IN ) LEVER OUT	
61H-YLWSN85003	PORT RELIEF VALVE ( G3-100 ) RANGE 100 TO 250 BAR		
61H-YLWSN85004	PORT RELIEF VALVE ( G4-200 ) RANGE 200 TO 315 BAR		
	<b><u>SPOOL CONTROL</u></b>		
61H-YLWSN83061	3 POSITION DETENT KIT TYPE ( 6-1 )		
61H-YLWSN83062	2 POSITION DETENT KIT TYPE ( 6-2 )		
61H-YLWSN83063	2 POSITION DETENT KIT TYPE ( 6-3 )		
61H-YLWSN83091	2 POSITION DETENT KIT TYPE ( 9-1 ) DETENT IN PORT A AND B WITH SPRING CENTRED		
61H-YLWSN83092	1 POSITION DETENT KIT TYPE ( 9-2 ) DETENT IN PORT B WITH SPRING CENTRED		
61H-YLWSN83093	1 POSITION DETENT KIT TYPE ( 9-3 ) DETENT IN PORT A WITH SPRING CENTRED		
61H-YLWSN83080	PNEUMATIC CONTROL KIT TYPE ( 8P )		
61H-YLWSN88EP3	ELECTRO PNEUMATIC CONTROL KIT TYPE ( 8EP3 ) 12 OR 24 VOLT ( TO BE ADDED TO ABOVE )		
61H-YLWSN830810	HYDRAULIC PILOT CONTROL KIT TYPE DOUBLE ACTING SPOOL ( 18IM )		
61H-YLWSN830811	HYDRAULIC PILOT CONTROL KIT TYPE MOTOR ACTING SPOOL ( 28IM )		
61H-JHP-1-1S-G2	HYDRAULIC PILOT JOY - STICK PER SECTION PILOT PRESSURE 2 - 20 Bar 1/4" Bsp PORTS		
61H-JHP-1-1S-FD	HYDRAULIC PILOT JOY - STICK FRICTION DETENT PILOT PRESSURE 2 - 20 Bar 1/4" Bsp PORTS		
61H-JHP-201-LCB	HYDRAULIC PILOT JOY - STICK 4 WAY PILOT PRESSURE 2 - 20 Bar 1/4" Bsp PORTS		
61H-YLWSN83082	DUAL CONTROL KIT TYPE ( 8D2 )		
61H-SN8-1DRHL	ROTARY DETENT KIT TYPE PLUS LEVER		
	<b><u>ACCESSORIES</u></b>		
61H-YLWSN84000	LEVER BOX	KIT TYPE ( L )	
61H-YLWSN84001	DUST CAP	KIT TYPE ( SPL )	
61H-YLWSN83008	END CAP	KIT TYPE ( 8 )	
61H-YLWSN12200	LEVER	KIT TYPE ( YLO9M12X200 )	
61H-YLPSN83000	RELIEF VALVE CARTRIDGE KIT TYPE ( XHG ) RANGE 25 - 315 BAR		
61H-YLPSN83002S	RELIEF VALVE SPRING KIT TYPE ( G2-63 ) RANGE 63 - 125 BAR		
61H-YLPSN83003S	RELIEF VALVE SPRING KIT TYPE ( G3-100 ) RANGE 100 - 250 BAR		
61H-YLPSN83004S	RELIEF VALVE SPRING KIT TYPE ( G4-200 ) RANGE 200 - 315 BAR		
61H-YLPEPCFSN8	PRESSURE COMPENSATED FLOW DIVIDER		
	<b><u>TECHNICAL SPECIFICATIONS:</u></b>		
	P - PORT	1" BSPP	
	A - PORT (SPRING)	1" BSPP	
	B - PORT (LEVER)	1" BSPP	
	T - PORT	1-1/4" BSPP	
	CO - PORT	1-1/4" BSPP	
	<b><u>RECOMMENDED FLOW RATE:</u></b>		
	250 LITRES PER MIN.		
	<b><u>MAX OPERATING PRESSURE:</u></b>		
	315 BAR		
	<b><u>PORT PRESSURE:</u></b>		
	315 BAR		
	<b><u>TANK LINE PRESSURE:</u></b>		
	25 BAR		
	<b>PLEASE NOTE: ALL O.E.M. NAMES OR NUMBERS ARE FOR REFERENCE USE ONLY</b>		<b>PAGE B 3</b>

Part Number	<b>VALVES PROPORTIONAL MODULAR</b>		RETAIL:	
	<b><u>PV- 4 PROPORTIONAL VALVE</u></b> <b>( 140 LITRES FLOW RATE )</b>		<b>01-10-2022</b>	
	<b><u>PV-4 Features;</u></b>			
	<ol style="list-style-type: none"> <li>1. Oil flow to an individual function is independent of the load pressure of this function</li> <li>2. Oil flow to one function is independent of the load pressure of other functions</li> <li>3 .The load sensing function can be used in a simple directional control valve to an advanced electrically controlled load- independent proportional valve</li> <li>4. Great spool control , spool flow or pressure selection from 10 litres to 130 litres</li> <li>5. Energy - saving</li> </ol>			
	<b><u>PROPORTIONAL VALVE MECHANICALLY ACTUATED SPRING CENTERED</u></b>			
61H-PV4-1-DASP	CONTROL VALVE PROPORTIONAL	PV - 4 / 1 - DA - SP	<b>ONE SPOOL</b>	
61H-PV4-2-DASP	CONTROL VALVE PROPORTIONAL	PV - 4 / 2 - DA - SP	<b>TWO SPOOL</b>	
61H-PV4-3-DASP	CONTROL VALVE PROPORTIONAL	PV - 4 / 3 - DA - SP	<b>THREE SPOOL</b>	
61H-PV4-4-DASP	CONTROL VALVE PROPORTIONAL	PV - 4 / 4 - DA - SP	<b>FOUR SPOOL</b>	
61H-PV4-5-DASP	CONTROL VALVE PROPORTIONAL	PV - 4 / 5 - DA - SP	<b>FIVE SPOOL</b>	
61H-PV4-6-DASP	CONTROL VALVE PROPORTIONAL	PV - 4 / 6 - DA - SP	<b>SIX SPOOL</b>	
61H-PV4-7-DASP	CONTROL VALVE PROPORTIONAL	PV - 4 / 7 - DA - SP	<b>SEVEN SPOOL</b>	
61H-PV4-8-DASP	CONTROL VALVE PROPORTIONAL	PV - 4 / 8 - DA - SP	<b>EIGHT SPOOL</b>	
61H-PV4-9-DASP	CONTROL VALVE PROPORTIONAL	PV - 4 / 9 - DA - SP	<b>NINE SPOOL</b>	
61H-PV4-10-DASP	CONTROL VALVE PROPORTIONAL	PV - 4 / 10 - DA - SP	<b>TEN SPOOL</b>	
	<b><u>PROPORTIONAL VALVE MECHANICALLY ACTUATED SPRING CENTERED WITH L/S PRV</u></b>			
61H-PV4-1-LSPR	CONTROL VALVE PROPORTIONAL WITH L/S PRV ;	PV - 4 / 1 - DA - SP-L/S PRV	<b>ONE SPOOL</b>	
61H-PV4-2-LSPR	CONTROL VALVE PROPORTIONAL WITH L/S PRV ;	PV - 4 / 2 - DA - SP-L/S PRV	<b>TWO SPOOL</b>	
61H-PV4-3-LSPR	CONTROL VALVE PROPORTIONAL WITH L/S PRV ;	PV - 4 / 3 - DA - SP-L/S PRV	<b>THREE SPOOL</b>	
61H-PV4-4-LSPR	CONTROL VALVE PROPORTIONAL WITH L/S PRV ;	PV - 4 / 4 - DA - SP-L/S PRV	<b>FOUR SPOOL</b>	
61H-PV4-5-LSPR	CONTROL VALVE PROPORTIONAL WITH L/S PRV ;	PV - 4 / 5 - DA - SP-L/S PRV	<b>FIVE SPOOL</b>	
61H-PV4-6-LSPR	CONTROL VALVE PROPORTIONAL WITH L/S PRV ;	PV - 4 / 6 - DA - SP-L/S PRV	<b>SIX SPOOL</b>	
61H-PV4-7-LSPR	CONTROL VALVE PROPORTIONAL WITH L/S PRV ;	PV - 4 / 7 - DA - SP-L/S PRV	<b>SEVEN SPOOL</b>	
61H-PV4-8-LSPR	CONTROL VALVE PROPORTIONAL WITH L/S PRV ;	PV - 4 / 8 - DA - SP-L/S PRV	<b>EIGHT SPOOL</b>	
61H-PV4-9-LSPR	CONTROL VALVE PROPORTIONAL WITH L/S PRV ;	PV - 4 / 9 - DA - SP-L/S PRV	<b>NINE SPOOL</b>	
61H-PV4-10-LSPR	CONTROL VALVE PROPORTIONAL WITH L/S PRV ;	PV - 4 / 10 - DA - SP-L/S PRV	<b>TEN SPOOL</b>	
	<b><u>TECHNICAL SPECIFICATIONS:</u></b>			
	P - PORT	3/4" BSPP		
	A - PORT (LEVER)	1/2" BSPP		
	B - PORT (SPRING)	1/2" BSPP		
	T - PORT	3/4" BSPP		
	<b><u>RECOMMENDED FLOW RATE:</u></b>			
	140 LITRES PER MIN.			
	<b><u>MAX OPERATING PRESSURE:</u></b>			
	350 BAR			
	<b><u>PORT PRESSURE:</u></b>			
	350 BAR			
	<b><u>TANK LINE PRESSURE:</u></b>			
	40 BAR			
				
	<b>PLEASE NOTE: ALL O.E.M. NAMES OR NUMBERS ARE FOR REFERENCE USE ONLY</b>		<b>PAGE B 4</b>	

Part Number	<b>VALVES PROPORTIONAL MODULAR</b>		RETAIL:
			01-10-2022
	<b><u>PV- 4 PROPORTIONAL VALVE STANDARD SERIES</u></b>		
	<b>( 140 LITRES FLOW RATE )</b>		
	<b><u>Pump Side Module Options:</u> ( Can be modified for Open Center fixed displacement pump )</b>		
61H-PV4P0201	For mechanically actuated valves Closed centre Pump with variable displacement		
61H-PV4P0205	Pilot oil supply for electrically actuated and connection for pilot oil pressure Close centre Pump variable displacement		
61H-PV4P0206H	Pilot oil supply for hydraulic actuation and connection for pilot oil pressure Closed centre Pump Side Module for pumps with variable displacement		
	<b><u>Mid-Inlet Options:</u></b>		
61H-PV4P0304	Max spool oil flow 230L/m With pilot oil supply for electrically actuation valves Closed centre Mid-Inlet Module for pumps with variable displacement		
	<b><u>Basic Module Options:</u></b>		
61H-PV4V04-G4	Non - damped pressure compensated valve		
61H-PV4V04U-G4	Non - damped pressure compensated valve with shock and suction valves		
	<b><u>A and B Port Options:</u></b>		
61H-PV4U300	Shock and Suction valve; Bar 50, 100, 150, 210, 250, 300, 350		
61H-PV4C	Suction and Anti-Cavitation Valve		
61H-PV4DST	Plug		
	<b><u>Spool options</u></b>		
61H-PV4201XXX	Double acting; Flow rates; 5, 10, 25, 40, 65, 100, 130 Litres		
61H-PV4202XXX	Motor acting ; Flow rates; 5, 10, 25, 40, 65, 100, 130 Litres		
61H-PV4204XXX	Single acting ; Flow rates; 10, 25, 40, 65, 100, Litres		
	<b><u>A; Side Actuation Options:</u></b>		
61H-PV4LM	Lever assembly with adjustments		
61H-PV4LEVER	Lever only		
	<b><u>B; Side Actuation Options:</u></b>		
61H-PV4CO	Cover Standard ( CO )		
61H-PV4FD	Cover Friction detent ( FD )		
61H-PV4HA-G2	Cover Hydraulic actuation ( HA )		
61H-EPVO-H0101	Cover Electrical on/off 11v - 30v ( EPVO )		
61H-EPVM-H0111	Cover Electrical proportional LVT 12VDC ( EPVM )		
61H-EPVM-H0121	Cover Electrical proportional LVT 24VDC ( EPVM )		
61H-EPVE-12	Cover Electrical proportional PWM 12VDC ( EPVE )		
61H-EPVE-24	Cover Electrical proportional PWM 24VDC ( EPVE )		
	<b><u>End Plate Options:</u></b>		
61H-PV4C0201	Standard End Plate		
61H-PV4C0202	Special End Plate with LS Port G1/4"		
	<b><u>Tie Rod Kits Options:</u></b>		
61H-PV4M-0XX	One to Ten Section Tie Kits		
	<b><u>Seal Kit per Section</u></b>		
61H-2BMPV400539	Seal Kit Work Section		
61H-2BMPV400375	Seal Kit LM CO HA FD		
61H-2BMPV400541	Seal Kit End Plate		
61H-2BMEPV0050	Seal Kit EPVO		
61H-2BMEPV0052	Seal Kit EPVM		
61H-PV4-LAB-1	Labour to set pressures and flow on test bench per spool		

Part Number	<b>VALVES PROPORTIONAL MODULAR</b>		RETAIL:
	<b><u>PV- 4 PROPORTIONAL VALVE (LS A/B) PRESSURE RELIEF SERIES</u></b>		<b>01-10-2022</b>
	<b>( 140 LITRES FLOW RATE )</b>		
	<b><u>Pump Side Module Options;</u> ( Can be modified for Open Center fixed displacement pump )</b>		
61H-PV4P0201	For mechanically actuated valves		
	Closed centre Pump with variable displacement		
61H-PV4P0205	Pilot oil supply for electrically actuated and connection for pilot oil pressure		
	Close centre Pump variable displacement		
61H-PV4P0206H	Pilot oil supply for hydraulic actuation and connection for pilot oil pressure		
	Closed centre Pump Side Module for pumps with variable displacement		
	<b><u>Mid-Inlet Options;</u></b>		
61H-PV4P0304	Max spool oil flow 230L/m With pilot oil supply for electrically actuation valves		
	Closed centre Mid-Inlet Module for pumps with variable displacement		
	<b><u>Basic Module Options;</u></b>		
61H-PV4V06-G4	Non - damped pressure compensated valve with adjustable LS on A/B pressure relief valve		
61H-PV4V06U-G4	Non - damped pressure compensated valve with adjustable LS on A/B pressure relief valve		
	with shock and suction valves		
	<b><u>Shock and Suction valve Options;</u></b>		
61H-PV4U300	Bar 50, 100, 150, 210, 250, 300, 350		
	<b><u>Spool options</u></b>		
61H-PV4201XXXAB	Double acting; Flow rates; 5, 10, 25, 40, 65, 100, 130 Litres		
61H-PV4202XXXAB	Motor acting ; Flow rates; 5, 10, 25, 40, 65, 100, 130 Litres		
	<b><u>A; Side Actuation Options;</u></b>		
61H-PV4LM	Lever assembly with adjustments		
61H-PV4LEVER	Lever only		
	<b><u>B; Side Actuation Options;</u></b>		
61H-PV4CO	Cover Standard ( CO )		
61H-PV4FD	Cover Friction detent ( FD )		
61H-PV4HA-G2	Cover Hydraulic actuation ( HA )		
61H-EPVO-H0101	Cover Electrical on/off 11v - 30v ( EPVO )		
61H-EPVM-H0111	Cover Electrical proportional LVT 12VDC ( EPVM )		
61H-EPVM-H0121	Cover Electrical proportional LVT 24VDC ( EPVM )		
61H-EPVE-12	Cover Electrical proportional PWM 12VDC ( EPVE )		
61H-EPVE-24	Cover Electrical proportional PWM 24VDC ( EPVE )		
	<b><u>End Plate Options;</u></b>		
61H-PV4C0201	Standard End Plate		
61H-PV4C0202	Special End Plate with LS Port G1/4"		
	<b><u>Tie Rod Kits Options;</u></b>		
61H-PV4M-0XX	One to Ten Section Tie Kits		
	<b><u>Seal Kit per Section</u></b>		
61H-2BMPV400539	Seal Kit Work Section		
61H-2BMPV400375	Seal Kit LM CO HA FD		
61H-2BMPV400541	Seal Kit End Plate		
61H-2BMEPV0050	Seal Kit EPVO		
61H-2BMEPV0052	Seal Kit EPVM		
			
			
61H-PV4-LAB-1	Labour to set pressures and flow on test bench per spool		
	<b>PLEASE NOTE: ALL O.E.M. NAMES OR NUMBERS ARE FOR REFERENCE USE ONLY</b>		<b>PAGE B 6</b>

Part Number	<b>REMOTE VALVE CONTROLS</b>		RETAIL:
			01-10-2022
	<b><u>PILOT CONTROL SERIES</u></b>		
61H-JHP-1-1S-G2	HYDRAULIC PILOT HAND LINEAR OPERATION ( Spring return; to center position )		
61H-JHP-1-1S-FD	HYDRAULIC PILOT HAND LINEAR OPERATION ( Friction detent; stop in any position )		
61H-JHP-1-1SLES	HYDRAULIC PILOT HAND LINEAR OPERATION ( Safety lock spring return; to center position )		
61H-JHP-201-LCB	HYDRAULIC PILOT HAND JOYSTICK OPERATION ( 4 X Way hand spring return; to center position )		
61H-PHP1-02-G2	HYDRAULIC PILOT FOOT LINEAR OPERATION ( Foot control spring return; to center position )		
61H-PVH-1	ELECTRIC PROPORTIONAL OPERATION ( Spring return; to center position EPVM Proportional Coil )		
	<b>JHP-1</b>		
	<b><u>TECHNICAL SPECIFICATIONS</u></b>		
	ALL 4 PORTS P - T - 1 - 2	1/4" BSPP	
	INPUT FLOW ;	5 - 20 L/min	
	INLET PRESSURE ;	30 - 100 BAR	
	OUTLET PRESSURE ;	0 - 20 BAR	
	BACK PRESSURE ;	3 BAR	
	STACKABLE	1 - 10 SECTIONS	
	<b>JHP-2</b>		
	<b><u>TECHNICAL SPECIFICATIONS</u></b>		
	ALL 6 PORTS P - T - 1 - 2 - 3 - 4 ;	1/4" BSPP	
	INPUT FLOW ;	5 - 20 L/min	
	INLET PRESSURE ;	30 - 100 BAR	
	OUTLET PRESSURE ;	0 - 20 BAR	
	BACK PRESSURE ;	3 BAR	
	<b>PHP-1</b>		
	<b><u>TECHNICAL SPECIFICATIONS</u></b>		
	ALL 4 PORTS P - T - 1 - 2	1/4" BSPP	
	INPUT FLOW ;	5 - 20 L/min	
	INLET PRESSURE ;	30 - 100 BAR	
	OUTLET PRESSURE ;	0 - 20 BAR	
	BACK PRESSURE ;	3 BAR	
	<b>61H-PVH-1</b>		
	<b><u>TECHNICAL SPECIFICATIONS</u></b>		
	STACKABLE BODYS ;	1 - 10 SECTIONS	
	RANGE ; 11 - 30 VDC. CURRENT CONSUMPTION; Max. 100 mA		
	OUTPUT VOLTAGE; Us 0.25 - 0.75 UDC. NEUTRAL VOLTAGE; Us 0.5 UDC		
	MAX. CURRENT OF THE POWER SWITCH; ON/OFF 1A. CONTROL ANGLE; Single 20°		



Part Number	<b>VALVES SOLENOID</b>		RETAIL:
			01-10-2022
	<b>NG 6 DIRECTIONAL CONTROL VALVES</b> ( 60 Litres Flow Rate 315 Bar Rated )		
62H-4WE6-E-XX	NG 6 DOUBLE SOLENOID VALVE	ALL PORTS BLOCKED	E CODE 3C2
62H-4WE6-H-XX	NG 6 DOUBLE SOLENOID VALVE	ALL PORTS OPEN	H CODE 3C3
62H-4WE6-J-XX	NG 6 DOUBLE SOLENOID VALVE	P CLOSED ; A & B & T OPEN	J CODE 3C4
62H-4WE6-G-XX	NG 6 DOUBLE SOLENOID VALVE	P TO T ; A & B BLOCKED	G CODE 3C6
62H-4WE6-D-XX	NG 6 SINGLE SOLENOID VALVE	P TO A ; T TO B ; IN TRANS CLOSED	D CODE 2B2
62H-4WE6-C-XX	NG 6 SINGLE SOLENOID VALVE	P TO A ; T TO B ; IN TRANS OPEN	C CODE 2B3
62H-4WE6-HA-XX	NG 6 SINGLE SOLENOID VALVE	ALL PORTS OPEN ; TWO POSITION	HA CODE 2B3B
	<b>VOLTAGE OPTIONS</b>		
	COIL SELECTION DC 12 VOLT OR DC 24 VOLT		
	COIL SELECTION AC 110 VOLT OR AC 220 VOLT		
	<b>NG 6 SUB PLATES</b>		
62H-ES3A38P	NG 6 SUB PLATE 3/8" P&T REAR A & B REAR		
62H-ES3D12P	NG 6 SUB PLATE 1/2" P&T REAR A & B REAR		
62H-ES3D12L	NG 6 SUB PLATE 1/2" P&T SIDE A & B SIDE		
62H-3ES3B38X3F	NG 6 SUB PLATE WITH RELIEF ONE STATION ( 55 - 315 Bar ) 3/8" P&T SIDE A & B SIDE		
	<b>MODULAR CONTROLS</b>		
62H-ZDB-6-V-P	NG 6 RELIEF VALVE ON PORT P ( 35 - 315 Bar Pressure )		
62H-Z2DB6VC	NG 6 RELIEF VALVE ON PORT A & B ( 35 - 315 Bar Pressure )		
62H-Z2S6AB40	NG 6 CHECK VALVE PILOT CONTROL ON PORT A & B ( 2 Bar Cracking Pressure )		
62H-Z2FS-6-AB3X	NG 6 THROTTLE & CHECK METERING OUT OR IN ON PORT A & B ( Swop Body 180 )		
62H-ZDR6DP2	NG 6 MODULAR PRESURE REDUCING VALVE ( 150 Bar - 0 Pressure )		
	<b>NG 6 ACCESSORIES</b>		
62H-Z8-60YC12V	NG 6 DC COIL 12V		
62H-Z8-60YC24V	NG 6 DC COIL 24V		
62H-J8-27YC110V	NG 6 AC COIL 110V		
62H-J8-27YC220V	NG 6 DC COIL 220V		
62H-C001123AC	HIRSHMAN & LED AC		
62H-C001123DC	HIRSHMAN & LED DC		
62H-M5X125L	BOLTS NG 6 M 5 X 125 ( each )		
62H-M5X165L	BOLTS NG 6 M 5 X 165 ( each )		
62H-M5X205L	BOLTS NG 6 M 5 X 205 ( each )		
62H-4WE6B	NG6 END CAP BLANKING SCREW		
	<b>NG 6 DOUBLE SOLENOID VALVE</b>		<b>NG 6 SINGLE SOLENOID VALVE</b>
			
	<b>PLEASE NOTE: ALL O.E.M. NAMES OR NUMBERS ARE FOR REFERENCE USE ONLY</b>		<b>PAGE C 1</b>

Part Number	VALVES SOLENOID		RETAIL:
			01-10-2022
	<b><u>NG 10 DIRECTIONAL CONTROL VALVES</u></b> ( 120 Litres Flow Rate 315 Bar Rated )		
62H-4WE10-E-XX	NG 10 DOUBLE SOLENOID VALVE	ALL PORTS BLOCKED	E CODE 3C2
62H-4WE10-H-XX	NG 10 DOUBLE SOLENOID VALVE	ALL PORTS OPEN	H CODE 3C3
62H-4WE10-J-XX	NG 10 DOUBLE SOLENOID VALVE	P CLOSED ; A & B & T OPEN	J CODE 3C4
62H-4WE10-G-XX	NG 10 DOUBLE SOLENOID VALVE	P TO T ; A & B BLOCKED	G CODE 3C6
62H-4WE10-D-XX	NG 10 SINGLE SOLENOID VALVE	P TO A ; T TO B ; IN TRANS CLOSED	D CODE 2B2
62H-4WE10-C-XX	NG 10 SINGLE SOLENOID VALVE	P TO A ; T TO B ; IN TRANS OPEN	C CODE 2B3
62H-4WE10-HA-XX	NG 10 SINGLE SOLENOID VALVE	ALL PORTS OPEN ; TWO POSITION	HA CODE 2B3B
	<b><u>VOLTAGE OPTIONS</u></b>		
	COIL SELECTION DC 12 VOLT OR DC 24 VOLT		
	COIL SELECTION AC 110 VOLT OR AC 220 VOLT		
	<b><u>NG 10 / 16 SUB PLATES</u></b>		
62H-ES5C34P	NG 10 SUB PLATE 3/4" P & T REAR A & B REAR		
62H-ES5C34L	NG 10 SUB PLATE 3/4" P & T SIDE A & B SIDE		
62H-ES5B34PLX3F	NG 10 SUB PLATE WITH RELIEF ONE STATION ( 55 - 315 Bar ) 3/4" P & T SIDE A & B SIDE		
62H-ES710P	NG 16 SUB PLATE 1" P & T REAR A & B REAR X & Y REAR		
	<b><u>MODULAR CONTROLS</u></b>		
62H-ZDB-10-V-P	NG 10 RELIEF VALVE ON PORT P	( 35 - 315 Bar Pressure )	
62H-Z2DB10VC	NG 10 RELIEF VALVE ON PORT A & B	( 35 - 315 Bar Pressure )	
62H-Z2S10AB40	NG 10 CHECK VALVE PILOT CONTROL ON PORT A & B	( 2 Bar Cracking Pressure )	
62H-Z2FS-10-AB3	NG 10 THROTTLE & CHECK METERING OUT OR IN ON PORT A & B	( Swop Plate 180 )	
62H-ZDR10DP2	NG 10 MODULAR PRESURE REDUCING VALVE	( 150 Bar - 0 Pressure )	
	<b><u>NG 10 ACCESSORIES</u></b>		
62H-Z8-120YC12V	NG 10 DC COIL 12V		
62H-Z8-120YC24V	NG 10 DC COIL 24V		
62H-J8-50YC110V	NG 10 AC COIL 110V		
62H-J8-50YC220V	NG 10 DC COIL 220V		
62H-C001123AC	HIRSHMAN & LED AC		
62H-C001123DC	HIRSHMAN & LED DC		
62H-M6X125L	BOLTS NG 10 M 6 X 125 ( each )		
62H-M6X165L	BOLTS NG 10 M 6 X 165 ( each )		
62H-M6X205L	BOLTS NG 10 M 6 X 205 ( each )		
62H-4WE10B	NG10 END CAP BLANKING SCREW		
	<b><u>NG 10 DIRECTIONAL CONTROL VALVES</u></b> ( 200 Litres Flow Rate 315 Bar Rated )		
62H-4WEH10J6X6	NG10 PILOT OIL CONTROL VALVE DOUBLE ACTING	J CODE	( Including NG6 pilot valve )
	<b><u>NG 16 DIRECTIONAL CONTROL VALVES</u></b> ( 300 Litres Flow Rate 315 Bar Rated )		
62H-4WEH16E6X6	NG16 PILOT OIL CONTROL VALVE DOUBLE ACTING	E CODE	( Including NG6 pilot valve )
62H-4WEH16G6X6	NG16 PILOT OIL CONTROL VALVE DOUBLE ACTING	G CODE	( Including NG6 pilot valve )
62H-4WEH16J6X6	NG16 PILOT OIL CONTROL VALVE DOUBLE ACTING	J CODE	( Including NG6 pilot valve )
62H-4WEH16R6X6	NG16 PILOT OIL CONTROL VALVE DOUBLE ACTING	R CODE	( Including NG6 pilot valve )
	<b><u>NG 10 DOUBLE SOLENOID</u></b>	<b><u>NG 10 SINGLE SOLENOID</u></b>	
			
PLEASE NOTE: ALL O.E.M. NAMES OR NUMBERS ARE FOR REFERENCE USE ONLY			PAGE C 2

<u>Part Number</u>	<b>MONOBLOCKS</b>	RETAIL:
		01-10-2022
	<b><u>NG 6 MONOBLOCK WITH RELIEF</u> ( 3/8" PORTS )</b>	
62H-3ES3B38X3F	NG 6 ONE STATION WITH RELIEF (55 - 315 Bar) 3/8" P&T SIDE A & B SIDE	
62H-EM213/2X3F	NG 6 TWO STATION WITH RELIEF (55 - 315 Bar) 3/8" P&T SIDE A & B SIDE	
62H-EM213/3X3F	NG 6 THREE STATION WITH RELIEF (55 - 315 Bar) 3/8" P&T SIDE A & B SIDE	
62H-EM213/4X3F	NG 6 FOUR STATION WITH RELIEF (55 - 315 Bar) 3/8" P&T SIDE A & B SIDE	
62H-EM213/5X3F	NG 6 FIVE STATION WITH RELIEF (55 - 315 Bar) 3/8" P&T SIDE A & B SIDE	
62H-EM213/6X3F	NG 6 SIX STATION WITH RELIEF (55 - 315 Bar) 3/8" P&T SIDE A & B SIDE	
	NG 6 MONOBLOCK PORTS ; P & T 1/2" BSPP A & B 3/8" BSPP	
62H-LDRDLWN	NG 6 RELIEF VALVE ADJUSTMENT RANGE ( 55 - 315 Bar ) STANDARD	
	<b><u>NG 10 MONOBLOCK WITH RELIEF</u> ( 1/2" PORTS )</b>	
62H-ES5B34PLX3F	NG 10 ONE STATION WITH RELIEF ( 55 - 315 Bar ) 3/4" P & T SIDE A & B SIDE	
62H-EM205/2X3F	NG 10 TWO STATION WITH RELIEF ( 55 - 315 Bar ) 3/4" P & T SIDE A & B SIDE	
62H-EM205/3X3F	NG 10 THREE STATION WITH RELIEF ( 55 - 315 Bar ) 3/4" P & T SIDE A & B SIDE	
62H-EM205/4X3F	NG 10 FOUR STATION WITH RELIEF ( 55 - 315 Bar ) 3/4" P & T SIDE A & B SIDE	
62H-EM205/5X3F	NG 10 FIVE STATION WITH RELIEF ( 55 - 315 Bar ) 3/4" P & T SIDE A & B SIDE	
	NG10 MONOBLOCK PORTS ; P & T 3/4" BSPP A & B 1/2" BSPP	
62H-LDRFLWN	NG 10 RELIEF VALVE ADJUSTMENT RANGE ( 55 - 315 Bar ) STANDARD	
	<b><u>ACCESSORIES</u></b>	
62H-NG6BP	NG 6 STATION BLANKING PLATE	
62H-NG10BP	NG 10 STATION BLANKING PLATE	



NG6



NG6



NG10



NG6



NG6



NG10



NG10 4WEH









NG16 4WEH

**3 POSITION**

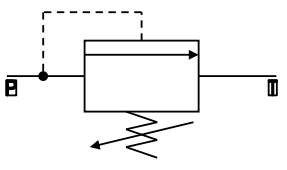

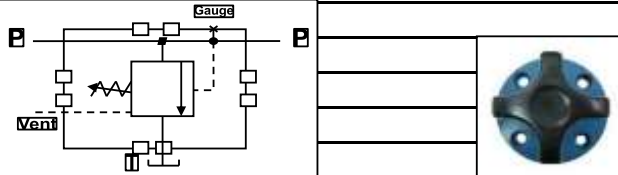

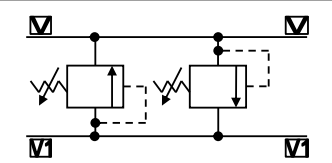

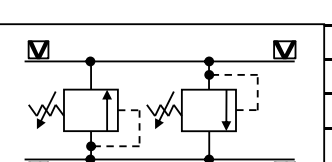

4WE	<b>E</b> 	<b>H</b> 	<b>J</b> 	<b>G</b> 
DSG	<b>3C2</b> 	<b>3C3</b> 	<b>3C4</b> 	<b>3C60</b> 
SWH	<b>C2</b> 	<b>C3</b> 	<b>C4</b> 	<b>C6</b> 
DG4V	<b>2C</b> 	<b>0C</b> 	<b>6C</b> 	<b>8C</b> 
B(L)*H	<b>34E0</b> 	<b>34EH</b> 	<b>34EY</b> 	<b>34EM</b> 

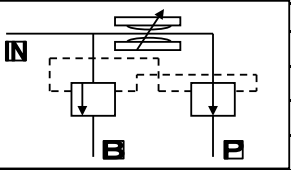

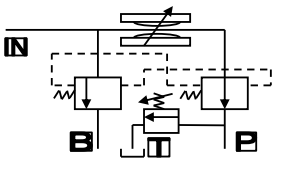

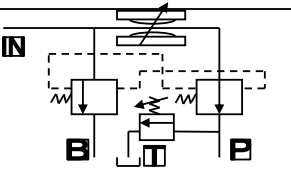

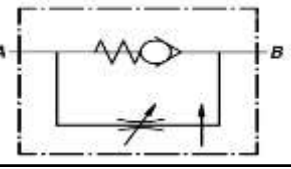

**2 POSITION**

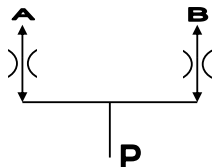

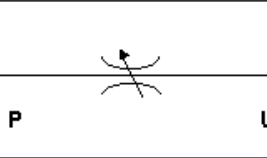

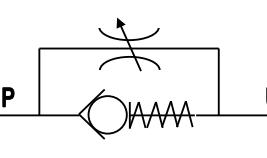

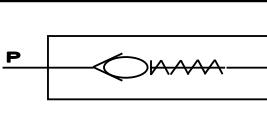

4WE	<b>D</b> 	<b>C</b> 	<b>HA</b> 	
DSG	<b>2B2</b> 	<b>2B3</b> 	<b>2B3B</b> 	
SWH	<b>B2</b> 	<b>B3</b> 	<b>C3B</b> 	
DG4V	<b>2A</b> 	<b>0A</b> 	<b>0B</b> 	
B(L)*H	<b>24E1 1</b> 	—	<b>24EH</b> 	

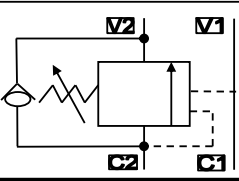

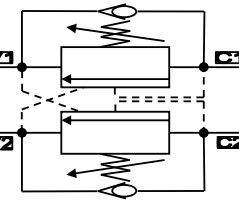

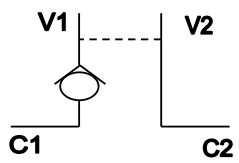

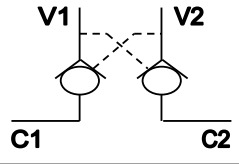

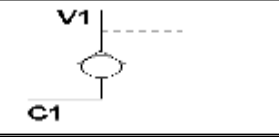

Part Number	HYDRAULIC PRESSURE CONTROL VALVES			RETAIL:
				13-04-2023
<u>RELIEF VALVES DIRECT ACTING</u>				
63H-V01200006	VMP 3/8"	3/8" BSPP THREADS	45 LITRE INLET	
63H-V01200008	VMP 1/2"	1/2" BSPP THREADS	70 LITRE INLET	
63H-V01200012	VMP 3/4"	3/4" BSPP THREADS	120 LITRE INLET	
63H-V01203516	VMPP 1"	1" BSPP THREADS	180 LITRE INLET	
<b>3 PORT BLOCK TYPE IN-LINE RELIEF VALVES ( P + P + T )</b>				
<b>MAXIMUM OPERATING PRESSURE: 350 BAR</b>				
<b>MATERIAL: STEEL</b>				
				
<u>RELIEF VALVES PILOT OPERATED BALANCED PISTON TYPE</u>				
63H-RVT-04330	RB - T04 - C	1/2" NPT THREADS	80 LITRE INLET	
63H-RVT-06330	RB - T06 - C	3/4" NPT THREADS	175 LITRE INLET	
63H-RVT-10330	RB - T10 - C	1 1/4" NPT THREADS	454 LITRE INLET	
63H-RMT-02-C	RM - T02 - C	1/4" NPT THREADS	PANEL MOUNT REMOTE CONTROL RELIEF	
<b>3 PORT BLOCK TYPE IN-LINE RELIEF VALVES ( P + P + T )</b>				
<b>OPTIONAL VENT AND GAUGE PORT</b>				
<b>MAXIMUM OPERATING PRESSURE: 210 BAR</b>				
<b>MATERIAL: CAST IRON</b>				
				
<u>RELIEF VALVE DUAL CROSS OVER</u>				
63H-V05900440	VAU / DE 3/8'	3/8" BSPP THREADS	45 LITRE INLET	
63H-V05900450	VAU / DE 1/2'	1/2" BSPP THREADS	70 LITRE INLET	
63H-V05900460	VAU / DE 3/4'	3/4" BSPP THREADS	120 LITRE INLET	
<b>DUAL ACTING RELIEFS, INLINE TYPE</b>				
<b>MAXIMUM OPERATING PRESSURE: 300 BAR</b>				
<b>MATERIAL: STEEL</b>				
				
<u>RELIEF VALVE DUAL CROSS PORT TYPE BMR / OMR MOTOR</u>				
63H-V05900500	VAU/DE1/2"CP/R BMR MOTOR CROSS OVER PORT RELIEF			
<b>DUAL ACTING RELIEFS, INLINE TYPE</b>				
<b>MAXIMUM OPERATING PRESSURE: 250 BAR</b>				
<b>MATERIAL: STEEL</b>				
				
<b>PLEASE NOTE: ALL O.E.M. NAMES OR NUMBERS ARE FOR REFERENCE USE ONLY</b>				<b>PAGE D 1</b>

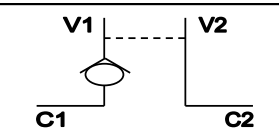

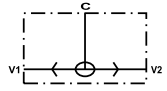
Part Number	HYDRAULIC FLOW CONTROL VALVES			RETAIL:
	<u>PRIORITY FLOW DIVIDER ADJUSTABLE</u>			15-02-2023
63H-V62150320	RF40/P	1/2" BSPP THREADS	40 LITRE INLET	
63H-V62150322	RF70/P	3/4" BSPP THREADS	70 LITRE INLET	
3 PORT BLOCK TYPE WITH ADJUSTABLE KNOB				
MAXIMUM OPERATING PRESSURE 250 BAR				
MATERIAL: CAST IRON				
				
<u>PRIORITY FLOW DIVIDER ADJUSTABLE WITH RELIEF VALVE</u>				
63H-V62150323	RF70/PV	3/4" BSPP THREADS	70 LITRE INLET	
3 PORT BLOCK TYPE WITH ADJUSTABLE KNOB				
MAXIMUM OPERATING PRESSURE: 250 BAR				
MATERIAL: CAST IRON				
				
<u>FLOW CONTROL ADJUSTABLE, PRESSURE COMPENSATED WITH RELIEF ON P PORT</u>				
70H-LKF-60	LKF-60	1/2 NPT THREADS	60 LITRE INLET	
70H-LKF-114	LKF-114	3/4 NPT THREADS	114 LITRE INLET	
3 PORT BLOCK TYPE: IN, CF, AND EX, THE EX PORT CAN ALSO BE PRESSURISED				
FLOW ADJUSTABLE LEVER				
MAXIMUM OPERATING PRESSURE : 210 BAR				
RELIEVES THROUGH THE EX PORT				
MATERIAL: CAST IRON				
				
<u>FLOW CONTROL ADJUSTABLE, PRESSURE COMPENSATED VALVE</u>				
63H-VSG523-2C	VRFU90-C 020	3/8" REGULATED FLOW 17 LITRES		
63H-VSG523-3C	VRFU90-C 030	1/2" REGULATED FLOW 28 LITRES		
				
PLEASE NOTE: ALL O.E.M. NAMES OR NUMBERS ARE FOR REFERENCE USE ONLY				PAGE D 2

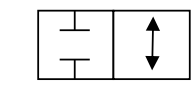

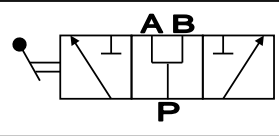



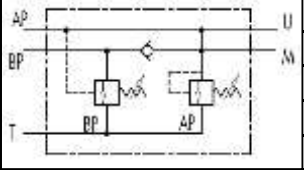

Part Number	HYDRAULIC FLOW CONTROL VALVES				RETAIL:
	<b>FLOW DIVIDER 50 / 50 SPLIT</b>				15-02-2023
63H-V36150316	VEQ-25	1/2" BSPP THREADS	INLET 25 / 40 LITRES		
63H-V36150317	VEQ-30	1/2" BSPP THREADS	INLET 40 / 60 LITRES		
<b>MAXIMUM OPERATING PRESSURE 250 BAR</b>					
<b>MATERIAL: CAST IRON</b>					
					
<b>FLOW RESTRICTOR ADJUSTABLE (NEEDLE TYPE)</b>					
63H-VSG5221	VRFB 04 1/4"	1/4" BSPP THREADS	15 LITRE INLET		
63H-VSG5222	VRFB 06 3/8"	3/8" BSPP THREADS	30 LITRE INLET		
63H-VSG5223	VRFB 08 1/2"	1/2" BSPP THREADS	45 LITRE INLET		
63H-VSG5224	VRFB 12 3/4"	3/4" BSPP THREADS	80 LITRE INLET		
<b>MAXIMUM OPERATING PRESSURE 350 BAR</b>					
<b>RESTRICTED BOTH WAYS</b>					
<b>MATERIAL: STEEL</b>					
					
<b>FLOW RESTRICTOR ADJUSTABLE (NEEDLE TYPE + CHECK)</b>					
63H-VSG5211	VRFU 04 1/4"	1/4" BSPP THREADS	15 LITRE INLET		
63H-VSG5212	VRFU 06 3/8"	3/8" BSPP THREADS	30 LITRE INLET		
63H-VSG5213	VRFU 08 1/2"	1/2" BSPP THREADS	45 LITRE INLET		
63H-VSG5214	VRFU 12 3/4"	3/4" BSPP THREADS	80 LITRE INLET		
<b>MAXIMUM OPERATING PRESSURE 350 BAR</b>					
<b>CHECKED ONE WAY FREE FLOW OTHER</b>					
<b>MATERIAL: STEEL</b>					
					
<b>FLOW CHECK VALVE</b>					
63H-VSG303C1	VUR 010 1/4"	1/4" BSPP THREADS	25 LITRE FLOW	0,5 BAR CRACKING	
63H-VSG303C2	VUR 020 3/8"	3/8" BSPP THREADS	40 LITRE FLOW	0,5 BAR CRACKING	
63H-VSG303C3	VUR 030 1/2"	1/2" BSPP THREADS	80 LITRE FLOW	0,5 BAR CRACKING	
63H-VSG303C4	VUR 040 3/4"	3/4" BSPP THREADS	110 LITRE FLOW	0,5 BAR CRACKING	
63H-VSG303C5	VUR 050 1"	1" BSPP THREADS	140 LITRE FLOW	0,5 BAR CRACKING	
63H-VSG303C6	VUR 060 1 1/4"	1 1/4" BSPP THREADS	200 LITRE FLOW	0,5 BAR CRACKING	
63H-VSG303C7	VUR 070 1 1/2"	1 1/2" BSPP THREADS	300 LITRE FLOW	0,5 BAR CRACKING	
63H-VSG303C54	VUR 050 16-1"	1" BSPP THREADS	150 LITRE FLOW	5 BAR CRACKING	
<b>MAXIMUM OPERATING PRESSURE 320 BAR</b>					
<b>CHECKED ONE WAY FREE FLOW OTHER</b>					
<b>MATERIAL: STEEL</b>					
					
<b>PLEASE NOTE: ALL O.E.M. NAMES OR NUMBERS ARE FOR REFERENCE USE ONLY</b>					<b>PAGE D 3</b>

Part Number	<b>HYDRAULIC LOAD HOLDING VALVES</b>			RETAIL:
				15-02-2023
	<b><u>OVERCENTRE VALVE SINGLE ACTING</u></b>			
63H-V2190A600	VBCD/A 06 SE	3/8" BSPP THREADS	35 LITRE INLET	
63H-V2190A800	VBCD/A 08 SE	1/2" BSPP THREADS	70 LITRE INLET	
63H-V2190A120	VBCD/A 12 SE	3/4" BSPP THREADS	90 LITRE INLET	
	SINGLE ACTING: 4 PORTED A + B ; C1 + C2:			
	MAXIMUM OPERATING PRESSURE: 250 BAR			
	MATERIAL: STEEL			
				
	<b><u>OVERCENTRE VALVE DOUBLE ACTING</u></b>			
63H-V2290A600	VBCD/A 06 DE	3/8" BSPP THREADS	35 LITRE INLET	
63H-V2290A800	VBCD/A 08 DE	1/2" BSPP THREADS	70 LITRE INLET	
63H-V2290A120	VBCD/A 12 DE	3/4" BSPP THREADS	90 LITRE INLET	
	DOUBLE ACTING: 4 PORTED A + B ; C1 + C2:			
	MAXIMUM OPERATING PRESSURE: 250 BAR			
	MATERIAL: STEEL			
				
	<b><u>CHECK VALVE PILOT OPERATED SINGLE ACTING</u></b>			
63H-VSG31104	VRSE-F 010 FF	1/4"		
63H-VSG31106	VRSE-F 015 FF	3/8" BSPP THREADS	30 LITRE INLET	
63H-VSG31108	VRSE-F 025 FF	1/2" BSPP THREADS	50 LITRE INLET	
	MAXIMUM OPERATING PRESSURE 350 BAR,			
	PILOT RATIO 1:4 OPENING PRESSURE 0,5 bar			
	MATERIAL: STEEL			
				
	<b><u>CHECK VALVE PILOT OPERATED DOUBLE ACTING</u></b>			
63H-VSG312F04	VRDE-F 010 FF	1/4" BSPP THREADS	30 LITRE INLET	
63H-VSG312F06	VRDE-F 015 FF	3/8" BSPP THREADS	30 LITRE INLET	
63H-VSG312F08	VRDE-F 025 FF	1/2" BSPP THREADS	50 LITRE INLET	
	MAXIMUM OPERATING PRESSURE 350 BAR,			
	PILOT RATIO 1:4 OPENING PRESSURE 0,5 bar			
	4 PORTS MATERIAL: STEEL			
				
<b>PLEASE NOTE: ALL O.E.M. NAMES OR NUMBERS ARE FOR REFERENCE USE ONLY</b>				<b>PAGE D 4</b>

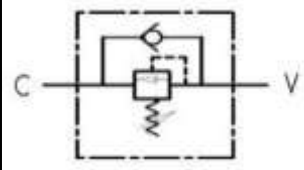

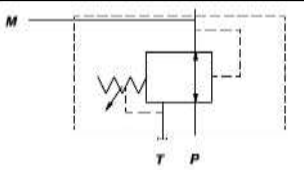

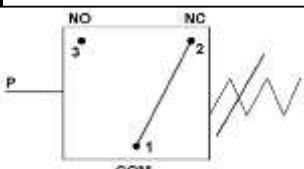
Part Number	<b>HYDRAULIC LOAD HOLDING VALVES</b>				RETAIL:
					15-02-2023
	<b><u>CHECK VALVE PILOT OPERATED SINGLE ACTING</u></b>				
63H-VSG34106	VBPS 020	3/8" BSPP THREADS	35 LITRE INLET	320 BAR	
63H-VSG34108	VBPS 030	1/2" BSPP THREADS	45 LITRE INLET	300 BAR	
63H-VSG34112	VBPS 040	3/4" BSPP THREADS	80 LITRE INLET	250 BAR	
63H-VSG34116	VBPS 050	1" BSPP THREADS	120 LITRE INLET	250 BAR	
	<b>MAXIMUM OPERATING PRESSURE 350 BAR,</b> <b>PILOT RATIO 1:4 OPENING PRESSURE 0,5 bar</b> <b>3 PORTS</b>				
	<b>MATERIAL: STEEL</b>				
					
	<b><u>CHECK VALVE PILOT OPERATED S/A WITH MANUAL LOCK</u></b>				
63H-VSG33106	VRPSE 015-FL	LEFT HAND TYPE	3/8" BSPP THREADS	30 LITRE INLET	
63H-VSG33206	VRPSE 015-FR	RIGHT HAND TYPE	3/8" BSPP THREADS	30 LITRE INLET	
	<b>MAXIMUM OPERATING PRESSURE: 350 BAR</b> <b>PILOT RATIO 1:4,5 OPENING PRESSURE 0,5 bar</b>				
	<b>MATERIAL: STEEL</b>				
					
	<b><u>SHUTTLE VALVE</u></b>				
63H-VSG3901	VU/SF 010	1/4" BSPP THREADS	500 BAR		
	<b>MATERIAL: STEEL</b>				
					
	<b><u>HIGH PRESSURE BALL VALVE 2 WAY</u></b>				
63H-EHV14-G	EHV DN 6	1/4" BSPP THREADS	500 BAR		
63H-EHV38-G	EHV DN 10	3/8" BSPP THREADS	500 BAR		
63H-EHV12-G	EHV DN 13	1/2" BSPP THREADS	500 BAR		
63H-EHV34-G	EHV DN 20	3/4" BSPP THREADS	315 BAR		
63H-EHV10-G	EHV DN 25	1" BSPP THREADS	315 BAR		
63H-EHV114-G	EHV DN 32	1-1/4" BSPP THREADS	315 BAR		
	<b>MATERIAL: STEEL</b>				
					
	<b><u>HIGH PRESSURE BALL VALVE 3 WAY OPEN CENTRE</u></b>				
63H-EHVL38-G	EHVL DN 10	3/8" BSPP THREADS	500 BAR		
63H-EHVL12-G	EHVL DN 13	1/2" BSPP THREADS	500 BAR		
63H-EHVL34-G	EHVL DN 20	3/4" BSPP THREADS	315 BAR		
	<b>MATERIAL: STEEL</b>				
					
<b>PLEASE NOTE: ALL O.E.M. NAMES OR NUMBERS ARE FOR REFERENCE USE ONLY</b>					<b>PAGE D 5</b>

Part Number	<b>HYDRAULIC DIVERTERS VALVES</b>				RETAIL:
					<b>15-02-2023</b>
	<b><u>DIVERTER VALVE THREE WAY OPEN CENTRE</u></b>				
63H-V70367A06	DDF3-A 020	3/8" BSPP THREADS	60 LITRE FLOW		
63H-V70367A08	DDF3-A 030	1/2" BSPP THREADS	90 LITRE FLOW		
63H-V70367A012	DDF3-A 040	3/4" BSPP THREADS	120 LITRE FLOW		
63H-V70367A016	DDF3-A 050	1" BSPP THREADS	180 LITRE FLOW		
63H-V70367A024	DDF3-A 070	1 1/2" BSPP THREADS	280 LITRE FLOW		
	<b>MAXIMUM OPERATING PRESSURE: 280 BAR</b>				
	<b>MATERIAL: CAST IRON</b>				
	<b><u>DIVERTER VALVE FOUR WAY OPEN CENTRE</u></b>				
63H-V70467A06	IDF4-A 020	3/8" BSPP THREADS	35 LITRE FLOW		
63H-V70467A08	IDF4-A 030	1/2" BSPP THREADS	50 LITRE FLOW		
63H-V70467A012	IDF4-A 040	3/4" BSPP THREADS	90 LITRE FLOW		
	<b>MAXIMUM OPERATING PRESSURE: 280 BAR</b>				
	<b>MATERIAL: CAST IRON</b>				
	<b><u>DIVERTER VALVE SIX WAY OPEN CENTRE</u></b>				
63H-V70667A08	DDF6-A 030	1/2" BSPP THREADS	90 LITRE FLOW		
63H-V70667A012	DDF6-A 040	3/4" BSPP THREADS	120 LITRE FLOW		
63H-V70667A016	DDF6-A 050	1" BSPP THREADS	180 LITRE FLOW		
	<b>MAXIMUM OPERATING PRESSURE: 280 BAR</b>				
	<b>MATERIAL: CAST IRON</b>				
	<b><u>DIVERTER VALVE TWO WAY 6 PORT SOLENOID OPERATED</u></b>				
63H-ELVSF240112	VS241/F1	3/8" BSPP THREADS	50 LITRE FLOW	12 VOLTS	
63H-ELVSF280112	VS281/F1	1/2" BSPP THREADS	90 LITRE FLOW	12 VOLTS	
	<b>MAXIMUM OPERATING PRESSURE: 310 BAR</b>				
	<b>STACKABLE UP TO 5 BODIES</b>				
	<b>MATERIAL: CAST IRON</b>				
<b>PLEASE NOTE: ALL O.E.M. NAMES OR NUMBERS ARE FOR REFERENCE USE ONLY</b>					<b>PAGE D 6</b>







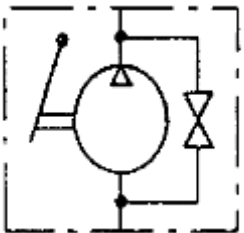

Part Number	<b>PRESSURE CONTROLLED VALVES</b>		RETAIL:
			15-02-2023
	<b><u>PRESSURE HI - LOW UNLOADING VALVE</u></b>		
63H-V12900513	VABP 1/2" BD 80 LITER MAX FLOW PORTS INLET 1/2" BSPP & 3/4" BSPP TANK		
63H-V12900514	VABP 3/4" BD 100 LITER MAX FLOW PORTS INLET 3/4" BSPP & 1" BSPP TANK		
	<b>MAX. OPERATING HIGH PRESSURE; PORT (AP) 50 : 350 Bar</b>		
	<b>MAX. OPERATING LOW PRESSURE; PORT (BP) 20 : 80 Bar</b>		
	<b>5 PORTS MATERIAL: STEEL</b>		
			
	<b><u>PRESSURE SEQUENCE VALVE</u></b>		
63H-V13900640	VS2C 3/8" 3/8" BSPP THREADS 35 LITRE INLET		
63H-V13900660	VS2C 1/2" 1/2" BSPP THREADS 70 LITRE INLET		
63H-V13900665	VS2C 3/4" 3/4" BSPP THREADS 100 LITRE INLET		
	<b>MAX. OPERATING PRESSURE RANGE: 10 : 180 BAR</b>		
	<b>MAX. OPERATING PRESSURE: 350 BAR</b>		
	<b>MATERIAL: STEEL</b>		
			
	<b><u>PRESSURE REDUCING VALVE</u></b>		
63H-V1190-07040	VRP 3/8" - A PRESSURE REDUCING VALVE PRESSURE RANGE 15 : 55 Bar 30 LITRES		
			
	<b><u>PRESSURE SWITCH</u></b>		
63H-60-P-02	P - 02 SPRING LOADED PISTON TYPE		
	<b>RANGE 10 - 400 bar ( diff % 15-20bar @ 400bar )</b>		
	<b>AC 110 - 250 ; DC 24V ; Thread 1/4" BSPP</b>		
			
<b>PLEASE NOTE: ALL O.E.M. NAMES OR NUMBERS ARE FOR REFERENCE USE ONLY</b>			<b>PAGE D 7</b>

Part Number	HYDRAULIC COMPONENTS				RETAIL:
	<u>END - STROKE VALVE</u>				15-02-2023
63H-V70900826	FCR-1T 80-NA12	NORMALLY OPEN	1/2" BSPP THREADS		
63H-V70900822	FCR-2T 80-NC12	NORMALLY CLOSED	1/2" BSPP THREADS		
					
	<u>SOLENOID OPERATED RELIEF VALVE</u>				
63H-BST061PN3D	BST- UNLOADING VALVE AVAILABLE IN 12 & 24 VOLT DC				
	MAXIMUM OPERATING PRESSURE: 250 BAR				
	FLOW RATE : 200 LITRES PER MINUTE				
	PORTS: 3/4" NPT				
					
	<u>PUMP PORT ADAPTOR FLANGES 90° DIAMOND 3 BOLT (EU TYPE)</u>				
63H-AFRG030060	RG 30 / 13.5	3/8" BSPP THREADS	PCD 30mm	13.5mm DIA PORT	
63H-AFRG030080	RG 30 / 13.5	1/2" BSPP THREADS	PCD 30mm	13.5mm DIA PORT	
63H-AFRG040080	RG 40 / 20.0	1/2" BSPP THREADS	PCD 40mm	20.0mm DIA PORT	
63H-AFRG040120	RG 40 / 20.0	3/4" BSPP THREADS	PCD 40mm	20.0mm DIA PORT	
63H-AFRG051120	RG 51 / 27.0	3/4" BSPP THREADS	PCD 51mm	27.0mm DIA PORT	
63H-AFRG051160	RG 51 / 27.0	1" BSPP THREADS	PCD 51mm	27.0mm DIA PORT	
	<u>PUMP PORT ADAPTOR FLANGES 90° SQUARE 4 BOLT (BOSCH TYPE)</u>				
63H-AFRGB35080	RGB 35 / 08	1/2" BSPP THREADS	PCD 35mm	15mm BOSCH	
63H-AFRGB40120	RGB 40 / 12	3/4" BSPP THREADS	PCD 40mm	20mm BOSCH	
63H-AFRGB55160	RGB 55 / 16	1" BSPP THREADS	PCD 55mm	26mm BOSCH	
	<u>DESCENT CONTROL VALVE</u>				
63H-VCG50520A0	VALVE	VSC 020 - A 3	3/8" BSPP THREADS	350 Bar	2 LITRE FLOW CONTROL
63H-VCG506200	ADAPTOR	CMFXVSC 020	3/8" BSPP THREADS	MALE & FEMALE	
	<u>BURST VALVE</u>				
63H-VCG3902015	VUBA 020	3/8" Thread	45 l/min	350 bar	
63H-VCG3903018	VUBA 030	1/2" Thread	70 l/min	350 bar	
63H-VCG3904022	VUBA 040	3/4" Thread	140 l/min	350 bar	
63H-VCG3912	ADAPTOR	CMFX VUMBA-020	3/8" BSPP THREADS	MALE & FEMALE	
63H-VCG3913	ADAPTOR	CMFX VUMBA-030	1/2" BSPP THREADS	MALE & FEMALE	
63H-VCG3914	ADAPTOR	CMFX VUMBA-040	3/4" BSPP THREADS	MALE & FEMALE	
<b>PLEASE NOTE: ALL O.E.M. NAMES OR NUMBERS ARE FOR REFERENCE USE ONLY</b>					<b>PAGE D 8</b>

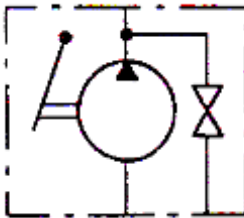
Part Number	<b>TRACTOR STEP - UP GEAR BOXES</b>		RETAIL:	
	<u><b>P.T.O. GEAR BOXES FEMALE DRIVE 12 Kw</b></u>		<b>15-02-2023</b>	
	<u><b>GROUP 2 PUMP</b></u>			
63H-BM60002050	GBML32-2- F-1/3,5 DRIVE FEMALE 1"3/8			
63H-BF31000800	SPLINE ADAPTOR Z=14 BF2T GROUP 2 PUMP			
	RATIO : 1 / 3,5 P.T.O. SPEED 540 rpm 12 Kw			
	COMMON ROTATION C/W VIEWED FROM			
	BACK OF TRACTOR. MATERIAL: ALUMINIUM			
				
	<u><b>P.T.O. GEAR BOXES FEMALE DRIVE 20Kw</b></u>			
	<u><b>GROUP 3 &amp; 2 PUMP</b></u>			
63H-BM70002050	GBML 52 - F - 1/3.4 DRIVE FEMALE 1"3/8			
63H-BF31003500	SPLINE ADAPTOR Z=18 BF3 GROUP 3 PUMP			
63H-BF31004000	SPLINE ADAPTOR Z=18 BF3/2T GROUP 2 PUMP			
	RATIO : 1 / 3,4 P.T.O. SPEED 540 rpm 20 Kw			
	COMMON ROTATION C/W VIEWED FROM			
	BACK OF TRACTOR . MATERIAL: ALUMINIUM			
				
	<u><b>P.T.O. GEAR BOXES MALE DRIVE 20Kw</b></u>			
	<u><b>GROUP 3 &amp; 2 PUMP</b></u>			
63H-BM70001040	GBML 52 - M - 1/3 DRIVE FEMALE 1"3/8			
63H-BF31003500	SPLINE ADAPTOR Z=18 BF3 GROUP 3 PUMP			
63H-BF31004000	SPLINE ADAPTOR Z=18 BF3/2T GROUP 2 PUMP			
	RATIO : 1 / 3 P.T.O. SPEED 540 rpm 20 Kw			
	COMMON ROTATION C/W VIEWED FROM			
	BACK OF TRACTOR . MATERIAL: ALUMINIUM			
				
	<u><b>P.T.O. GEAR BOXES MALE / FEMALE THROUGH DRIVE 20Kw</b></u>			
	<u><b>GROUP 3 &amp; 2 PUMP</b></u>			
63H-BM12390003	GBML 52/B - 8 - 1/3 THROUGH DRIVE FEMALE / MALE 1"3/8			
63H-BF31003500	SPLINE ADAPTOR Z=18 BF3 GROUP 3 PUMP			
63H-BF31004000	SPLINE ADAPTOR Z=18 BF3/2T GROUP 2 PUMP			
	RATIO : 1 / 3 P.T.O. SPEED 540 rpm 20 Kw			
	COMMON ROTATION C/W VIEWED FROM			
	BACK OF TRACTOR . MATERIAL: ALUMINIUM			
				
<b>PLEASE NOTE: ALL O.E.M. NAMES OR NUMBERS ARE FOR REFERENCE USE ONLY</b>			<b>PAGE D 9</b>	

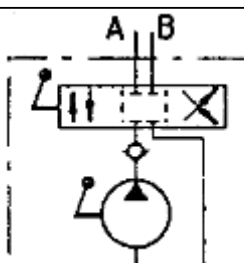
<u>Part Number</u>	<b>PUMP OUTBOARD BEARING SUPPORT</b>		RETAIL:
			15-02-2023
	<b><u>GROUP 2 OUTBOARD BEARING SUPPORT</u></b>		
63H-BU12020001	STSU / 2 C 18 mm SHAFT		
63H-BF31000800	SPLINE ADAPTOR BF2Tz 14 TOOTH GROUP 2		
	18 mm PARALLEL KEY SHAFT SPIGOT 36.5mm		
	MOUNTING 4 BOLT 71.4 mm X 96mm		
	LOAD 1300 N @ 2000 RPM distance (X) 40 mm		
	TO TAKE GROUP 2 PUMP / MOTOR 1 : 8 TAPER 36.5mm SPIGOT		
63H-BU12020007	STSUR / 2 C 22 mm SHAFT		
63H-BF31002000	SPLINE ADAPTOR BF2Tz 15 TOOTH GROUP 2		
	22 mm PARALLEL KEY SHAFT SPIGOT 50.8mm		
	MOUNTING 4 BOLT 71.4 mm X 96mm		
	LOAD 1400 N @ 2000 RPM distance (X) 50 mm		
	TO TAKE GROUP 2 PUMP / MOTOR 1 : 8 TAPER 36.5mm SPIGOT		
70H-TK-STSU-ZFD	STSU/ZF-D 1 : 5 TAPER SHAFT		
70H-TK-BF2TZ17	SPLINE ADAPTOR BF2Tz 17 TOOTH BOSCH GROUP 2		
	1 ; 5 TAPER KEY SHAFT SPIGOT 80 mm		
	MOUNTING 4 BOLT 72 mm X 100 mm		
	LOAD 1400 N @ 2000 RPM distance (X) 50 mm		
	TO TAKE GROUP 2 BOSCH PUMP / MOTOR 1 : 5 TAPER 80mm SPIGOT		
	<b><u>GROUP 3 OUTBOARD BEARING SUPPORT</u></b>		
63H-BU12030001	STSU / 3 C 24 mm SHAFT		
63H-BF31003500	SPLINE ADAPTOR BF3 18 TOOTH GROUP 3		
	TO TAKE A GROUP 3 PUMP 1 : 8 TAPER		
	24 mm PARALLEL KEY SHAFT SPIGOT 50.8mm		
	MOUNTING 4 BOLT 98.2 mm X 128 mm		
	LOAD 1400 N @ 2000 RPM distance (X) 50 mm		
	TO TAKE A GROUP 3 PUMP / MOTOR 1 : 8 TAPER 50mm SPIGOT		
	<b><u>SPLINED COUPLINGS</u></b>		
	<b><u>MALE</u></b>		
63H-BF31000400	BF1-1	GR.1 MALE SPLINE 12 TOOTH 20 X 17 GROUP 1 TAPER 1 : 8	
63H-BF31000800	BF2TV	GR.2T MALE SPLINE 14 TOOTH 25 X 22 GROUP 2 TAPER 1 : 8	
63H-BF31002000	BF2Tz15	GR.2T MALE SPLINE 15 TOOTH 28 X 25 GROUP 2 TAPER 1 : 8	
70H-TK-BF2TZ17	BF2BZ17	GR.2B MALE SPLINE 17 TOOTH 28 X 25 GROUP 2 TAPER 1 : 5	
63H-BF31003500	BF3	GR.3 MALE SPLINE 18 TOOTH 35 X 31 GROUP 3 TAPER 1 : 8	
63H-BF31004000	BF3/2T	GR.2T MALE SPLINE 18 TOOTH 35 X 31 GROUP 2 TAPER 1 : 8	
			
	<b>PLEASE NOTE: ALL O.E.M. NAMES OR NUMBERS ARE FOR REFERENCE USE ONLY</b>		

Part Number	HAND PUMPS			RETAIL:
				15-02-2023
	<u>INLINE TYPE</u>			
64H-PAM0142005	PAM - 20 - SV	20cc per rev	300 bar	
64H-PAM0144005	PAM - 40 - SV	40cc per rev	230 bar	
64H-PAM0290000	HAND LEVER			
	SUPPLIED WITH RUBBER BELLOWS AND RELEASE VALVE			
				
	<u>TANK TYPE FOR SINGLE ACTING CYLINDER</u>			
64H-PAM0141203	PAM - T - SV 12	12cc per rev	380 bar	
64H-PAM0142503	PAM - T - SV 25	25cc per rev	300 bar	
64H-PAM0144503	PAM - T - SV 45	45cc per rev	230 bar	
64H-PAM0290000	HAND LEVER			
	SUPPLIED WITH RUBBER BELLOWS, RELIEF VALVE, AND RELEASE VALVE			
				
	<u>TANK TYPE WITH DIVERTER FOR DOUBLE ACTING CYLINDER</u>			
64H-PAM0151203	PAM-TD - SV 12	12cc per rev	380 bar	
64H-PAM0152503	PAM-TD - SV 25	25cc per rev	300 bar	
64H-PAM0154503	PAM-TD - SV 45	45cc per rev	230 bar	
64H-PAM0290000	HAND LEVER			
	SUPPLIED WITH RUBBER BELLOWS, RELIEF VALVE, AND 4 WAY DIVERTER			
				
PLEASE NOTE: ALL O.E.M. NAMES OR NUMBERS ARE FOR REFERENCE USE ONLY				PAGE E 1





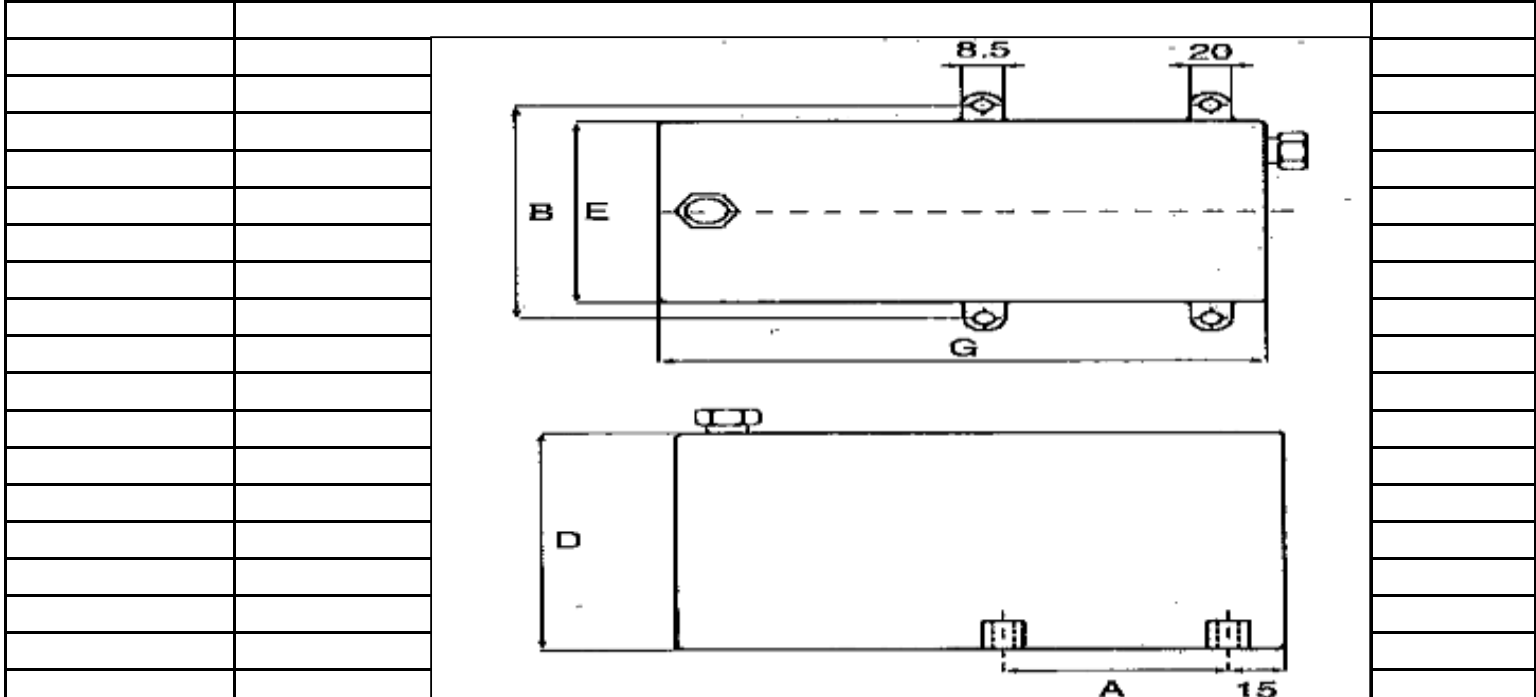

Part Number	<b>HAND PUMPS</b>		RETAIL:
			15-02-2023
	<b><u>STEEL TANKS FOR HAND PUMPS</u></b>		
	<b>CAPACITY</b>		
64H-PM00220001	1 LITRE		
64H-PM00220003	3 LITRE		
64H-PM00220005	5 LITRE		
64H-PM00220010	10 LITRE		
	<b>TANKS SUPPLIED WITH PUMP GASKET, MOUNTING BOLTS, FILLER BREATHER, DRAIN PLUG AND SUCTION PIPE</b>		
			

<b>DIMENSIONS</b>						
<b>CAPACITY</b>	<b>A</b>	<b>B</b>	<b>D</b>	<b>E</b>	<b>G</b>	
1 LITRE	90mm	120mm	150mm	100mm	120mm	
3 LITRE	90mm	120mm	150mm	100mm	247mm	
5 LITRE	90mm	195mm	175mm	175mm	200mm	
10 LITRE	90mm	195mm	175mm	175mm	376mm	









Part Number	HEAT EXCHANGERS										RETAIL:
											15-02-2023
<b>TAK - BOK HEAT EXCHANGERS</b>											
<b>WARNING; PROTECT COOLER FROM BURSTING A BY-PASS VALVE SHOULD ALWAYS BE FITTED</b>											
	MODEL	kcal/h	SYSTEM	FLOW	PORTS	PRESS	PRESS	FAN	SIZES		
	TYPE	$\Delta t=30C$	KW	L/min	NPT	MAX	DROP	CURRENT	L X H X W	Kg	
65H-AH1012DC12	AH10 12	6000	3.7 / 5.5	100	1"	20 bar	1 bar	12 V DC	417 X 360 X 200	10	
65H-AH1012DC24	AH10 12	6000	3.7 / 5.5	100	1"	20 bar	1 bar	24 V DC	417 X 360 X 200	10	
65H-AH1012AC220	AH10 12	6000	3.7 / 5.5	100	1"	20 bar	1 bar	220 V AC 1 PHASE	417 X 360 X 200	10	
65H-AH1012AC380	AH10 12	6000	3.7 / 5.5	100	1"	20 bar	1 bar	380 V AC 3 PHASE	417 X 360 X 200	10	
65H-AH1417DC12	AH14 17	10 000	5.6 / 7.5	100	1"	20 bar	0.8	12 V DC	570 X 411 X 200	11	
65H-AH1417DC24	AH14 17	10 000	5.6 / 7.5	100	1"	20 bar	0.8	24 V DC	570 X 411 X 200	11	
65H-AH1417AC220	AH14 17	10 000	5.6 / 7.5	100	1"	20 bar	0.8	220 V AC 1 PHASE	570 X 411 X 200	11	
65H-AH1417AC380	AH14 17	10 000	5.6 / 7.5	100	1"	20 bar	0.8	380 V AC 3 PHASE	570 X 411 X 200	11	
65H-AH1470DC12	AH14 70	14 000	7.5 / 11.5	200	1-1/4"	20 bar	1 bar	12 V DC	570 X 407 X 225	13	
65H-AH1470DC24	AH14 70	14 000	7.5 / 11.5	200	1-1/4"	20 bar	1 bar	24 V DC	570 X 407 X 225	13	
65H-AH1470AC220	AH14 70	14 000	7.5 / 11.5	200	1-1/4"	20 bar	1 bar	220 V AC 1 PHASE	570 X 407 X 225	13	
65H-AH1470AC380	AH14 70	14 000	7.5 / 11.5	200	1-1/4"	20 bar	1 bar	380 V AC 3 PHASE	570 X 407 X 225	13	
<b>NO WARRANTEE ON COOLERS IF BYPASS SYSTEM NOT FITTED WITH COOLER</b>											
<b>HEAT EXCHANGER BODY AND FAN HOUSING ONLY</b>											
65H-AH1012-C	417 X 360 X 200 HEAT EXCHANGER BODY										
65H-AH1417-C	570 X 411 X 200 HEAT EXCHANGER BODY										
65H-AH1470-C	570 X 407 X 225 HEAT EXCHANGER BODY										
<b>FAN MOTORS AH10 12 SERIES</b>											
65H-FAN10DC12	DC 12 VOLT FAN MOTOR										
65H-FAN10DC24	DC 24 VOLT FAN MOTOR										
65H-FAN10AC220	AC 220 VOLT FAN MOTOR 1 PHASE										
65H-FAN10AC380	AC 380 VOLT FAN MOTOR 3 PHASE										
<b>FAN MOTORS AH 14 17 &amp; AH14 70 SERIES</b>											
65H-FAN14DC12	DC 12 VOLT FAN MOTOR										
65H-FAN14DC24	DC 24 VOLT FAN MOTOR										
65H-FAN14AC220	AC 220 VOLT FAN MOTOR 1 PHASE										
65H-FAN14AC380	AC 380 VOLT FAN MOTOR 3 PHASE										
<b>BY - PASS PROTECTION VALVE 5 BAR</b>											
63H-VSG303C54	VU 16-1"	1"	BSPP THREADS	150 LITRE FLOW	5 BAR CRACKING						
											
<b>PLEASE NOTE: ALL O.E.M. NAMES OR NUMBERS ARE FOR REFERENCE USE ONLY</b>										<b>PAGE F 1</b>	

Part Number	<b>HYDRAULIC COMPONENTS</b>						RETAIL:
							15-02-2023
	<b>ACCUMULATORS HR SERIES (DIAPHRAGM TYPE)</b>						
	<b>TYPE</b>	<b>MAX PRESS</b>	<b>NITROGEN VOL</b>	<b>MAX PRELOAD</b>	<b>MAX FLOW</b>	<b>CONNECTION</b>	
		<b>BAR</b>	<b>LITRE</b>	<b>BAR</b>	<b>LITRE / MIN</b>	<b>mm</b>	
65H-ACH0100	H100R	250	0.15	150	15	M 18X1.5	
65H-ACH0350	H350R	250	0.35	150	35	M 18X1.5	
65H-ACH0500	H500R	250	0.45	150	45	M 18X1.5	
65H-ACH0700	H700R	250	0.7	150	70	M 18X1.5	
65H-ACH1000	H1000R	250	1.0	150	100	M 18X1.5	
65H-ACH1400	H1400R	250	1.4	150	140	M 18X1.5	
65H-ACH2000	H2000R	250	2.0	150	200	M 18X1.5	
65H-ACH4000	H4000R	250	4.0	150	380	M 18X1.5	
	<b>NITROGEN FILLING AND TESTING</b>						
65H-ACCUFILL	FILLING AND TESTING LABOUR						
65H-ACAR500	TYPE A R CHARGING VALVE KIT 5/8" UNF THREAD SUPPLIED IN BOX						
	<b>ACCUMULATORS H 210 SERIES</b>						
							
<b>PLEASE NOTE: ALL O.E.M. NAMES OR NUMBERS ARE FOR REFERENCE USE ONLY</b>						<b>PAGE F 2</b>	

HYDRAULIC TANKS & ACCESSORIES							RETAIL:
							15-02-2023
<b>WELDLESS STEEL TANKS FOR POWER PACKS</b>							( WITHOUT LID )
	<b>TOTAL OIL CAPACITY</b>	<b>LENGTH</b>	<b>WIDTH</b>	<b>HEIGHT</b>	<b>FEET</b>	<b>TOTAL HEIGHT</b>	
66H-025TANK	25 LITRE	390 mm	280 mm	232 mm	+48 mm	280 mm	
66H-040TANK	40 LITRE	460 mm	330 mm	272 mm	+56 mm	328 mm	
66H-070TANK	70 LITRE	560 mm	400 mm	332 mm	+69 mm	401 mm	
66H-100TANK	100 LITRE	630 mm	450 mm	372 mm	+77 mm	449 mm	
66H-160TANK	160 LITRE	730 mm	520 mm	432 mm	+90 mm	522 mm	
66H-250TANK	250 LITRE	850 mm	610 mm	502 mm	+105 mm	607 mm	
<b>BLANK STEEL LIDS FOR TANKS</b>							
	<b>TOTAL OIL CAPACITY</b>	<b>LENGTH</b>	<b>WIDTH</b>	<b>THICKNESS</b>			
66H-25LID	25 LITRE	440 mm	330 mm	3 mm			
66H-40LID	40 LITRE	510 mm	380 mm	3 mm			
66H-70LID	70 LITRE	610 mm	450 mm	4 mm			
66H-100LID	100 LITRE	680 mm	500 mm	4 mm			
66H-160LID	160 LITRE	780 mm	570 mm	5 mm			
66H-250LID	250 LITRE	900 mm	660 mm	5 mm			
							
<b>TECHNICAL SPECIFICATIONS</b>							
TANK SIDES 2mm THICK AND WELDLESS							
TANK LID FROM 3mm TO 5mm THICK WITH ROUNDED 90° EDGES							
TANKS SUPPLIED WITH LID GASKET, 1/2" BSP DRAIN, OIL LEVEL THREADED HOLES							
<b>TANK TOP FILLER BREATHERS</b>							
66H-EFB450H64	TANK TOP FILLER BREATHER 29mm O/D MESH 40 micron						
77H-HB-55-72	TANK TOP FILLER BREATHER 50mm O/D MESH 40 micron						
66H-TAP9010-L	TANK TOP FILLER BREATHER ( Anti-splash HB-2 )						
<b>LEVEL GAUGES</b>							
66H-EAVT-I-076	EAVT-I 076BM12Z - 3" ( 76mm BOLT CENTER 12mm NUT )						
66H-EAVT-I-127	EAVT-I 127BM12Z - 5" ( 127mm BOLT CENTER 12mm NUT )						
66H-EAVT-I-254	EAVT-I 254BM12Z - 10" ( 254mm BOLT CENTER 12mm NUT )						
<b>LEVEL GAUGES PLUG TYPE</b>							
66H-EAPP-12	3/4" BSPP THREAD ALUMINIUM ALLOY PLUG TYPE LEVEL GAUGE						
66H-EAPP-16	1" BSPP THREAD ALUMINIUM ALLOY PLUG TYPE LEVEL GAUGE						
66H-EAPP-20	1-1/4" BSPP THREAD ALUMINIUM ALLOY PLUG TYPE LEVEL GAUGE						
<b>ELECTRICAL LEVEL INDICATOR</b>							
66H-EAVL-L-150	ELECTRICAL LEVEL INDICATOR PORT 1" BSPP NORMALLY OPEN SWITCH						
66H-EAVL-L-200	ELECTRICAL LEVEL INDICATOR PORT 1" BSPP NORMALLY OPEN SWITCH						
66H-EAVL-L-250	ELECTRICAL LEVEL INDICATOR PORT 1" BSPP NORMALLY OPEN SWITCH						
66H-ALEX-BUZZ	BUZZER WARNING 24 v						
<b>PLEASE NOTE: ALL O.E.M. NAMES OR NUMBERS ARE FOR REFERENCE USE ONLY</b>							<b>PAGE G 1</b>

<u>Part Number</u>	<b>HYDRAULIC TANKS &amp; ACCESSORIES</b>				RETAIL:
					15-02-2023
<b>PRE - CUT OUT STEEL LIDS FOR TANKS</b>					
	<b>ELECTRIC MOTORS</b>	<b>FRAME SIZE</b>	<b>BELL HOUSING</b>	<b>PUMP TYPE ; TO FIT VERTICALLY INSIDE TANK</b>	
66H-25L160	0.25 / 0.37	71	160	GP1 / GP2	
66H-25L200	0.55 / 0.75 / 1.1 / 1.5	80	200	GP1 / GP2	
66H-25L250	2.2 / 3.0 / 4.0	100	250	GP1	
66H-40L160	0.25 / 0.37	71	160	GP1 / GP2	
66H-40L200	0.55 / 0.75 / 1.1 / 1.5	80	200	GP1 / GP2 / GP3	
66H-40L250	2.2 / 3.0 / 4.0	100	250	GP1 / GP2	
66H-70L200	0.55 / 0.37 / 1.1 / 1.5	80	200	GP1 / GP2 / GP2+2 / GP3	
66H-70L250	2.2 / 3.0 / 4.0	100	250	GP1 / GP2 / GP3	
66H-70L300	5.5 / 7.5 / 9.2	132	300	GP1 / GP2 / GP3	
66H-100L200	0.55 / 0.37 / 1.1 / 1.5	50	200	GP1 / GP2 / GP2+2 / GP3	
66H-100L250	2.2 / 3.0	100	250	GP1 / GP2 / GP2+2 / GP3	
66H-100L250	4	112	250	GP1 / GP2 / GP2+2 / GP3 / A10V18 / A10V28	
66H-100L300	5.5 / 7.5 / 9.2	132	300	GP1 / GP2 / GP3 / A10V18 / A10V28	
66H-100L350	11.0 / 15.0	160	350	GP1 / GP2 / GP3	
66H-100L350	18.5 / 22	180	350	GP1 / GP2 / GP3	
66H-160L250	2.2 / 3.0	100	250	GP1 / GP2 / GP2+2 / GP3 / GP3+2 / A10V18 / 28 / 45	
66H-160L250	4	112	250	GP1 / GP2 / GP2+2 / GP3 / GP3+2 / A10V18 / 28 / 45	
66H-160L300	5.5 / 7.5 / 9.2	132	300	GP1 / GP2 / GP2+2 / GP3 / GP3+2 / A10V18 / 28 / 45	
66H-160L350	11.0 / 15.0	160	350	GP1 / GP2 / GP2+2 / GP3 / GP3+2 / A10V18 / 28 / 45	
66H-160L350	18.5 / 22.0	180	350	GP1 / GP2 / GP2+2 / GP3 / GP3+2 / A10V18 / 28 / 45	
66H-250L300	5.5 / 7.5 / 9.2	132	300	GP1 / GP2 / GP2+2 / GP3 / GP3+2 / A10V18 / 28 / 45 / 71 / 100	
66H-250L350	11.0 / 15.0	160	350	GP1 / GP2 / GP2+2 / GP3 / GP3+2 / A10V18 / 28 / 45 / 71 / 100	
66H-250L350	18.5 / 22.0	180	350	GP1 / GP2 / GP2+2 / GP3 / GP3+2 / A10V18 / 28 / 45 / 71 / 100	
66H-250L400	30	200	400	GP1 / GP2 / GP2+2 / GP3 / GP3+2 / A10V18 / 28 / 45 / 71 / 100	
	<b>TANK SIZE</b>	<b>LEVEL GAUGE</b>	<b>RETURN LINE FILTER</b>	<b>FILLER BREATHER</b>	
	25 L	76 mm	68Ø mm 1/2" BSPP PORTS	30Ø mm 29mm FILLER	
	40 L	127mm	90Ø mm 1" BSPP PORTS	30Ø mm 29mm FILLER	
	70 L	127mm	90Ø mm 1" BSPP PORTS	60Ø mm ANTI SPLASH	
	100 L	127mm	90Ø mm 1" BSPP PORTS	60Ø mm ANTI SPLASH	
	160 L	127mm	90Ømm 1" BSPP PORTS	60Ø mm ANTI SPLASH	
	250 L	127mm	90Ø mm 1" BSPP PORTS	60Ø mm ANTI SPLASH	
					
<b>PLEASE NOTE: ALL O.E.M. NAMES OR NUMBERS ARE FOR REFERENCE USE ONLY</b>					



Part Number	HYDRAULIC GAUGES				RETAIL:	
					15-02-2023	
<b><u>GAUGE BOTTOM ENTRY</u></b>						
	<b><u>PRESSURE RANGE</u></b>	<b><u>FACE O/D</u></b>	<b><u>THREAD BSP</u></b>			
66H-AMGR63010	0 / 10 Bar	63 mm	1/4"			
66H-AMGR63025	0 / 25 Bar	63 mm	1/4"			
66H-AMGR63060	0 / 60 Bar	63 mm	1/4"			
66H-AMGR63100	0 / 100 Bar	63 mm	1/4"			
66H-AMGR63160	0 / 160 Bar	63 mm	1/4"			
66H-AMGR63250	0 / 250 Bar	63 mm	1/4"			
66H-AMGR63400	0 / 400 Bar	63 mm	1/4"			
66H-AMGR63600	0 / 600 Bar	63 mm	1/4"			
<b><u>GAUGE REAR ENTRY</u></b>						
	<b><u>PRESSURE RANGE</u></b>	<b><u>FACE O/D</u></b>	<b><u>THREAD BSP</u></b>			
66H-AMGF63010	0 / 10 Bar	63 mm	1/4"			
66H-AMGF63025	0 / 25 Bar	63 mm	1/4"			
66H-AMGF63060	0 / 60 Bar	63 mm	1/4"			
66H-AMGF63100	0 / 100 Bar	63 mm	1/4"			
66H-AMGF63160	0 / 160 Bar	63 mm	1/4"			
66H-AMGF63250	0 / 250 Bar	63 mm	1/4"			
66H-AMGF63400	0 / 400 Bar	63 mm	1/4"			
66H-AMGF63600	0 / 600 Bar	63 mm	1/4"			
<b><u>GAUGE DIGITAL BOTTOM ENTRY 0 : 700 Bar</u></b>						
	<b><u>PRESSURE RANGE</u></b>	<b><u>FACE O/D</u></b>	<b><u>THREAD BSP</u></b>			
66H-SD700	700 Bar	63 mm	1/4"			
	DIGITAL READ OUT 0 : 700 Bar					
	ON / OFF BUTTON					
	AUTO OFF BUTTON					
	LIGHT BUTTON					
	MAX RECALL PRESSURE BUTTON					
	RESET BUTTON					
<b><u>QUADRIGAUGE</u></b>						
	<b><u>PRESSURE RANGE</u></b>	<b><u>0 - 5000 PSI</u></b>	<b><u>0 - 350 BAR</u></b>			
66H-03740019	1/8" NPT FEMALE FITTING ON GAUGE MALE ON HOSE					
<b><u>GAUGE HOSE ASSEMBLIES &amp; TEST POINTS</u></b>						
	<b><u>PRESSURE RANGE ;</u></b>	<b><u>GAUGE THREAD</u></b>	<b><u>MINI MESS THREAD</u></b>	<b><u>LENGTH</u></b>		
54P-MMH-64001	0 / 700 Bar	1/4" BSPP	M16X2	1000 mm		
54P-MMH-64001-5	0 / 700 Bar	1/4" BSPP	M16X2	1500 mm		
54P-MMH-64002	0 / 700 Bar	1/4" BSPP	M16X2	2500 mm		
<b><u>MINI MESS TEST POINT</u></b>						
						
54P-MMP-02R	MINI MESS POINT	1/8" BSPP	M16X2			
54P-MMP-04R	MINI MESS POINT	1/4" BSPP	M16X2			
54P-MMP-06R	MINI MESS POINT	3/8" BSPP	M16X2			
54P-MMP-08R	MINI MESS POINT	1/2" BSPP	M16X2			
54P-MMP-04N	MINI MESS POINT	1/4" NPT	M16X2			
54P-MMP-06N	MINI MESS POINT	3/8" NPT	M16X2			
<b><u>GAUGE ISOLATOR</u></b>						
66H-DFPE1G0400	GAUGE ISOLATOR 1/4" NPT THREAD					
PLEASE NOTE: ALL O.E.M. NAMES OR NUMBERS ARE FOR REFERENCE USE ONLY					PAGE G 3	

Part Number	FILTRATION ACCESSORIES			RETAIL:
				01-10-2022
	<u>IN LINE SPIN - ON FILTER HEADS</u> (RETURN LINE ONLY)			
	<u>DESCRIPTION</u>	<u>PORTS</u>	<u>FLOW RATE @ 40 KPA</u>	
67H-EFPS1	FILTER HEAD	3/4" BSP	75 LITRES	
67H-EFPS3	FILTER HEAD	1- 1/4" BSP	200 LITRES	
67H-EFPS5	FILTER HEAD	1- 1/2" BSP	350 LITRES	TWIN HEADS
67H-EFPS-3	MAX WORKING PRESSURE 12 bar		BY-PASS SPRING 1.7 bar	RETURN SIDE
67H-EFSS-3	MAX WORKING PRESSURE 12 bar		BY-PASS SPRING 0.25 bar	SUCTION SIDE
				
	<u>SPIN - ON FILTER CANS</u>			
	<u>DESCRIPTION</u>	<u>FILTER HEAD</u>	<u>FLOW RATE</u>	<u>MICRON</u>
67H-EEPS1-10	SPIN-ON CAN	3/4" BSP	70 LITRES @ 20 Kpa	10
67H-EEPS1-20	SPIN-ON CAN	3/4" BSP	120 LITRES @ 20 Kpa	25
67H-EEPS3-10	SPIN-ON CAN	1-1/4" BSP & 1-1/2" BSP	200 LITRES @ 20 Kpa	10
67H-EEPS3-20	SPIN-ON CAN	1-1/4" BSP & 1-1/2" BSP	300 LITRES @ 20 Kpa	25
67H-EEPS3-90	SPIN-ON CAN	1-1/4" BSP & 1-1/2" BSP	300 LITRES @ 20 Kpa	90
	<u>VISUAL INDICATORS</u>			
67H-PA	PA GAUGE RETURN SIDE 1/8" BSP		GAUGE 0 - 12 bar	
67H-VA	VA GAUGE SUCTION SIDE 1/8" BSP		GAUGE 0 - 76 cm Hg	
	<u>SUCTION STRAINERS</u> (SUCTION LINE ONLY 125 MICRON)			
	<u>DESCRIPTION</u>	<u>PORTS</u>	<u>FLOW RATE</u>	
67H-EEST1	SUCTION STRAINER	3/8" BSP PORT	15 LITRES	
67H-EEST2	SUCTION STRAINER	1/2" BSP PORT	22 LITRES	
67H-EEST5	SUCTION STRAINER	3/4" BSP PORT	56 LITRES	
67H-EEST6	SUCTION STRAINER	1" BSP PORT	100 LITRES	
67H-EEST10	SUCTION STRAINER	1-1/4" BSP PORT	140 LITRES	
67H-EEST11	SUCTION STRAINER	1-1/2" BSP PORT	200 LITRES	
67H-EEST17	SUCTION STRAINER	2" BSP PORT	340 LITRES	
	PA			
	VA			
				
	PLEASE NOTE: ALL O.E.M. NAMES OR NUMBERS ARE FOR REFERENCE USE ONLY			PAGE H 1

Part Number	FILTRATION ACCESSORIES			RETAIL:
	<b>TANK TOP RETURN LINE FILTER BODY (INCLUDES 20 MICRON ELEMENT)</b>			01-10-2022
	<b>DESCRIPTION</b>	<b>FILTER HEAD</b>	<b>FLOW RATE @ 15 KPA</b>	
67H-EFRM2BBB	TANK TOP & FILTER ELEMENT	1/2" BSP	110 LITRES	
67H-EFRM6BCB	TANK TOP & FILTER ELEMENT	3/4" BSP	150 LITRES	
67H-EFRM8BDB	TANK TOP & FILTER ELEMENT	1" BSP	210 LITRES	
67H-EFRM11BEB	TANK TOP & FILTER ELEMENT	1-1/4" BSP	300 LITRES	
67H-EFRM15BFB	TANK TOP & FILTER ELEMENT	1-1/2" BSP	425 LITRES	
67H-EFRM17BHB	TANK TOP & FILTER ELEMENT	2" BSP	600 LITRES	
	MAX WORKING PRESSURE 3 bar	BY-PASS 170 Kpa	1 bar = 100 Kpa	
	<b>TANK TOP RETURN ELEMENTS (RETURN LINE ONLY, BY-PASS SET 170 KPA)</b>			
	<b>DESCRIPTION</b>	<b>FILTER HEAD</b>	<b>FLOW RATE @ 15 KPA</b>	<b>MICRON</b>
67H-EERM2BP20	FILTER ELEMENT	1/2" BSP	60 LITRES	20
67H-EERM6BP20	FILTER ELEMENT	3/4" BSP	100 LITRES	20
67H-EERM8BP20	FILTER ELEMENT	1" BSP	150 LITRES	20
67H-EERM11BP20	FILTER ELEMENT	1-1/4" BSP	300 LITRES	20
67H-EERM15BP20	FILTER ELEMENT	1-1/2" BSP	450 LITRES	20
67H-EERM17BP20	FILTER ELEMENT	2" BSP	550 LITRES	20
	<b>TANK TOP RETURN ELEMENTS (RETURN LINE ONLY, BY-PASS SET 170 KPA)</b>			
	<b>DESCRIPTION</b>	<b>FILTER HEAD</b>	<b>FLOW RATE @ 40 KPA</b>	<b>MICRON</b>
67H-EERM2BP10	FILTER ELEMENT	1/2" BSP	45 LITRES	10
67H-EERM6BP10	FILTER ELEMENT	3/4" BSP	85 LITRES	10
67H-EERM8BP10	FILTER ELEMENT	1" BSP	150 LITRES	10
67H-EERM11BP10	FILTER ELEMENT	1-1/4" BSP	300 LITRES	10
67H-EERM15BP10	FILTER ELEMENT	1-1/2" BSP	350 LITRES	10
67H-EERM17BP10	FILTER ELEMENT	2" BSP	450 LITRES	10
	<b>HIGH PRESSURE IN LINE FILTER (INCLUDES ELEMENT &amp; INDICATOR)</b>			
67H-EFPU3BC11B	FILTER HIGH PRESSURE 3/4" BSP INCLUDING ELEMENT 10 MICRON & INDICATOR		110 LITRES	
67H-EFPU5BD11B	FILTER HIGH PRESSURE 1" BSP INCLUDING ELEMENT 10 MICRON & INDICATOR		160 LITRES	
67H-EFPU8BE11B	FILTER HIGH PRESSURE 1-1/4" BSP INCLUDING ELEMENT 10 MICRON & INDICATOR		280 LITRES	
67H-EFPU10BF11B	FILTER HIGH PRESSURE 1-1/2" BSP INCLUDING ELEMENT 10 MICRON & INDICATOR		400 LITRES	
67H-EEPU3BP10	FILTER HIGH PRESSURE ELEMENT FOR EFPU3 3/4"	10 MICRON	FLOW RATE 110 LITRES	
67H-EEPU5BP10	FILTER HIGH PRESSURE ELEMENT FOR EFPU5 1"	10 MICRON	FLOW RATE 160 LITRES	
67H-EEPU8BP10	FILTER HIGH PRESSURE ELEMENT FOR EFPU8 1-1/4"	10 MICRON	FLOW RATE 280 LITRES	
67H-EEPU10BP10	FILTER HIGH PRESSURE ELEMENT FOR EFPU10 1-1/2"	10 MICRON	FLOW RATE 400 LITRES	
<b>PLEASE NOTE: ALL O.E.M. NAMES OR NUMBERS ARE FOR REFERENCE USE ONLY</b>				

Part Number	DRIVE COUPLINGS								RETAIL:
									01-10-2022
	<u>PARALLEL SHAFT COUPLINGS H R C (TAPER LOCK)</u>								
	<b>MOTOR</b>	<b>TAPER</b>	<b>PUMP</b>	<b>TAPER</b>	<b>COUPLING</b>	<b>RUBBER</b>	<b>ELECTRIC</b>	<b>ELECTRIC</b>	
	<b>SHAFT</b>	<b>LOCK BUSH</b>	<b>SHAFT</b>	<b>LOCK BUSH</b>	<b>HRC TYPE</b>	<b>ELEMENT</b>	<b>FRAME</b>	<b>K.W.</b>	
68H-090FASS	19	1108 19	5/8"	1108 5/8	090F	090	80	0.55 - 0.75	
68H-090FASS	19	1108 19	3/4"	1108 3/4	090F	090	80	0.55 - 0.75	
68H-090FASS	24	1108 24	3/4"	1108 3/4	090F	090	90	1.1 - 1.5	
68H-090FASS	24	1108 24	7/8"	1108 7/8	090F	090	90	1.1 - 1.5	
68H-110FASS	28	1610 028	5/8"	1610 010	110 F	110	100 / 112	2.20 - 4.00	
68H-110FASS	28	1610 028	3/4"	1610 012	110 F	110	100 / 112	2.20 - 4.00	
68H-110FASS	38	1610 038	5/8"	1610 010	110 F	110	132	5.50 - 9.00	
68H-110FASS	38	1610 038	3/4"	1610 012	110 F	110	132	5.50 - 9.00	
68H-130FASS	42	1610 042	5/8"	1610 010	130 F	130	160	11.00 - 15.00	
68H-130FASS	42	1610 042	3/4"	1610 012	130 F	130	160	11.00 - 15.00	
68H-130FASS	42	1610 042	7/8"	1610 014	130 F	130	160	11.00 - 15.00	
68H-130FASS	42	1610 042	1"	1610 100	130 F	130	160	11.00 - 15.00	
68H-130FASS	42	1610 042	1-1/8"	1610 102	130 F	130	160	11.00 - 15.00	
68H-130FASS	42	1610 042	1-1/4"	1610 104	130 F	130	160	11.00 - 15.00	
68H-150FASS	48	2012 048	7/8"	2012 014	150 F	150	180	18.00 - 22.00	
68H-150FASS	48	2012 048	1"	2012 100	150 F	150	180	18.00 - 22.00	
68H-150FASS	48	2012 048	1-1/8"	2012 102	150 F	150	180	18.00 - 22.00	
68H-150FASS	48	2012 048	1-1/4"	2012 104	150 F	150	180	18.00 - 22.00	
68H-180FASS	55	2517 055	1"	2517 100	180 F	180	200	30.00	
68H-180FASS	55	2517 055	1-1/8"	2517 102	180 F	180	200	30.00	
68H-180FASS	55	2517 055	1-1/4"	2517 104	180 F	180	200	30.00	
	<u>TAPER LOCK BUSH METRIC</u>								
68H-1108M	1108 SIZES : 16 mm 18 mm 19 mm 20 mm 22 mm 24 mm								
68H-1610M	1610 SIZES : 16 mm 19 mm 22 mm 25 mm 28 mm 30 mm 32 mm 38 mm 42 mm								
68H-2012M	2012 SIZES : 22 mm 25 mm 28 mm 30 mm 32 mm 38 mm 42 mm 48 mm								
68H-2517M	2517 SIZES : 25 mm 28 mm 30 mm 32 mm 38 mm 42 mm 48 mm 55 mm								
	<u>TAPER LOCK BUSH IMPERIAL</u>								
68H-1108I	TYPE 1108 SIZES : 5/8" 7/8" 3/4" 1"								
68H-1610I	TYPE 1610 SIZES : 5/8" 7/8" 3/4" 1" 1-1/8" 1-1/4"								
68H-2012I	TYPE 2012 SIZES : 7/8" 3/4" 1" 1-1/8" 1-1/4"								
68H-2517I	TYPE 2517 SIZES : 1" 1-1/8" 1-1/4"								
	<u>COUPLING FLANGE</u>								
68H-090-F	TYPE HRC 090 F								
68H-110-F	TYPE HRC 110 F								
68H-130-F	TYPE HRC 130 F								
68H-150-F	TYPE HRC 150 F								
68H-180-F	TYPE HRC 180 F								
	<u>COUPLING RUBBER</u>								
68H-090ELEM	TYPE HRC 090 NATURAL ELEMENT								
68H-110ELEM	TYPE HRC 110 NATURAL ELEMENT								
68H-130ELEM	TYPE HRC 130 NATURAL ELEMENT								
68H-150ELEM	TYPE HRC 150 NATURAL ELEMENT								
68H-180ELEM	TYPE HRC 180 NATURAL ELEMENT								
	<u>POWER RATINGS WORKED OUT AS BELOW</u>								
	<u>SERVICE FACTOR X 2,5 @ 1440 RPM</u>								

PLEASE NOTE: ALL O.E.M. NAMES OR NUMBERS ARE FOR REFERENCE USE ONLY

Part Number	DRIVE COUPLINGS								RETAIL:
									13-04-2023
<b>PARALLEL SHAFT COUPLING (BLANK)</b>									
	DESC	Nm @ 1500 rpm	MAX Kw cont	MAX rpm	MAX BORE	LENGTH	NYLON OD	STEEL OD	
68H-HOF28	HOF-28	20	3	5000	28	84	67	44	
68H-HOF42	HOF-42	76	11	5000	42	88	87	60	
68H-HOF55	HOF-55	133	22	4000	55	124	121	80	
<b>NYLON SLEEVE ONLY</b>									
68H-HOF28NS	SLEEVE HOF 28 NS								
68H-HOF42NS	SLEEVE HOF 42 NS								
68H-HOF55NS	SLEEVE HOF 55 NS								
<b>PARALLEL SHAFT COUPLING (BORED)</b>									
<b>HUBS PRE - BORED ;</b>									
<b>PRICED PER SIDE ; 2 SIDES TO BE ADDED TO A BLANK UNIT PRICE</b>									
	DESCRIPTION	BORE	KEY	LENGTH	NYLON OD	STEEL OD			
68H-28-GP2-1-8	HOF-28- 1 ; 8 TAPER	1;8	3.2mm x 3.2mm	84	67	44			
68H-28-1-2	HOF-28-1/2"	1/2"	3.2mm x 3.2mm	84	67	44			
68H-28-5-8	HOF-28-5/8"	5/8"	4.8mm X 4.8mm	84	67	44			
68H-28-3-4	HOF-28-3/4"	3/4"	4.8mm X 4.8mm	84	67	44			
68H-28-7-8	HOF-28-7/8"	7/8"	6.3mm X 6.3mm	84	67	44			
68H-28-1	HOF-28-1"	1"	6.3mm X 6.3mm	84	67	44			
68H-28-1-1-8	HOF-28-1-1/8"	1-1/8"	6.3mm X 6.3mm	84	67	44			
68H-28-16mm	HOF-28-16mm	16mm	4mm X 4mm	84	67	44			
68H-28-18mm	HOF-28-18mm	18mm	6mm X 6mm	84	67	44			
68H-28-19mm	HOF-28-19mm	19mm	6mm X 6mm	84	67	44			
68H-28-22mm	HOF-28-22mm	22mm	6mm X 6mm	84	67	44			
68H-28-24mm	HOF-28-24mm	24mm	8mm X 8mm	84	67	44			
68H-28-28mm	HOF-28-28mm	28mm	8mm X 8mm	84	67	44			
68H-42-GP-1-8	HOF-42- 1 ; 8 TAPER	1;8	3.2mm x 3.2mm	88	87	60			
68H-42-3-4	HOF-42-3/4"	3/4"	4.8mm X 4.8mm	89	87	60			
68H-42-7-8	HOF-42-7/8"	7/8"	6.3mm X 6.3mm	88	87	60			
68H-42-1	HOF-42-1"	1"	6.3mm X 6.3mm	88	87	60			
68H-42-1-1-8	HOF-42-1-1/8"	1-1/8"	6.3mm X 6.3mm	88	87	60			
68H-42-1-1-4	HOF-42-1-1/4"	1-1/4"	8mm X 8mm	88	87	60			
68H-42-19mm	HOF-42-19mm	19mm	6mm X 6mm	88	87	60			
68H-42-22mm	HOF-42-22mm	22mm	6mm X 6mm	89	87	60			
68H-42-24mm	HOF-42-24mm	24mm	8mm X 8mm	88	87	60			
68H-42-25mm	HOF-42-25mm	25mm	8mm X 7mm	88	87	60			
68H-42-28mm	HOF-42-28mm	28mm	8mm X 8mm	88	87	60			
68H-42-32mm	HOF-42-32mm	32mm	10mm X 8mm	88	87	60			
68H-42-38mm	HOF-42-38mm	38mm	10mm X 10mm	88	87	60			
68H-42-42mm	HOF-42-42mm	42mm	12mm X 12mm	89	87	60			
68H-55-1-1-4	HOF-55-1-1/4"	1-1/4"	8mm X 8mm	124	121	80			
68H-55-32mm	HOF-55-1-32mm	32mm	10mm X 8mm	124	121	80			
<b>SPLINED BILLETS</b>									
<b>FEMALE</b>									
68H-09DIN	09 TOOTH	D.I.N.	( 16.2 mm )	OD					
68H-09SAE	09 TOOTH	SAE A	5/8"	( 15.8 mm )	OD				
68H-10SAE	10 TOOTH		17mm	OD					
68H-11SAE	11 TOOTH		3/4"	OD					
68H-13SAE	13 TOOTH	SAE B	7/8"	OD					
68H-14SAE	14 TOOTH	SAE C	1-1/4"	OD					
68H-15SAE	15 TOOTH	SAE BB	1"	OD					
<b>MALE / FEMALE ADAPTORS</b>									
68H-09-13SAE	9 - 13 TOOTH ADAPTOR								
68H-13-14SAE	13 - 14 TOOTH ADAPTOR								
<b>PLEASE NOTE: ALL O.E.M. NAMES OR NUMBERS ARE FOR REFERENCE USE ONLY</b>									





Part Number	DRIVE COUPLINGS						RETAIL:
							15-02-2023
<u>GROUP 1 ( 1:8 TAPER )</u>							
	<b>PUMP GROUP:</b>	<b>DESCRIPTION:</b>	<b>CODE:</b>	<b>K.W:</b>	<b>FRAME:</b>	<b>SHAFT:</b>	
68H-BH10200002	1	14/1	HE2	0.25 - 0.37	71	14	
68H-BH10200006	1	19/1	HE6	0.55 - 0.75	80	19	
68H-BH10200037	1	24/1	HE41	1.10 - 1.50	90	24	
68H-BH10200014	1	28/1	HE16	2.20 - 4.00	100	28	
<u>GROUP 2 ( 1:8 TAPER )</u>							
	<b>PUMP GROUP:</b>	<b>DESCRIPTION:</b>	<b>CODE:</b>	<b>K.W:</b>	<b>FRAME:</b>	<b>SHAFT:</b>	
68H-BH10200043	2	19/2	HE47	0.55 - 0.75	80	19	
68H-BH10200013	2	24/2	HE15	1.1 - 1.5	90	24	
68H-BH10200018	2	28/2	HE20	2.20 - 4.00	112	28	
68H-BH10200025	2	38/2	HE29	5.50 - 9.00	132	38	
68H-BH10200029	2	42/2	HE33	11.00 - 15.00	160	42	
<u>GROUP 3 ( 1:8 TAPER )</u>							
	<b>PUMP GROUP:</b>	<b>DESCRIPTION:</b>	<b>CODE:</b>	<b>K.W:</b>	<b>FRAME:</b>	<b>SHAFT:</b>	
68H-BH10200084	3	28/3	HE48	2.20 - 4.00	112	28	
68H-BH10200026	3	38/3	HE30	5.50 - 9.00	132	38	
68H-BH10200030	3	42/3	HE34	11.00 - 15.00	160	42	
68H-BH10200033	3	48/3	HE37	18.00 - 22.00	180	48	
<u>COUPLINGS; CBT HI / LO SERIES</u>							
	<b>PUMP GROUP:</b>	<b>DESCRIPTION:</b>	<b>ENGINE</b>	<b>ENGINE P.C.D.</b>	<b>SHAFT:</b>		
68H-HC219MC048	CBT	6.3 / 2.1	GX;120/160/200	90	3/4"		
68H-HC325NC048	CBT	10.9 / 3.6	GX;/240/270/340/390	127	1"		
<u>RUBBER INSERTS</u>							
68H-BT39200300	FLEXIBLE INSERT FOR : 14/1 , 19/1						
68H-BT39200400	FLEXIBLE INSERT FOR : 24/1 , 28/1 , 24/2 , 28/2 , 28/28						
68H-BT39200500	FLEXIBLE INSERT FOR : 38/2 , 38/3						
68H-BT39200600	FLEXIBLE INSERT FOR : 42/2 , 48/2 , 42/3 , 48/3						
NOTE: ABOVE DATA TAKEN FROM METRIC THREE PHASE 4 POLE 50Hz ELECTRIC MOTORS, SPEED 1450 RPM							
							
PLEASE NOTE: ALL O.E.M. NAMES OR NUMBERS ARE FOR REFERENCE USE ONLY							PAGE 13

<u>Part Number</u>	<b>BELLHOUSINGS</b>						<b>RETAIL:</b>
							<b>15-02-2023</b>
	<b><u>GROUP1</u> ( SPIGOT 25.4 )</b>						
				<b>ELECTRIC MOTOR</b>			
	<b>PUMP GROUP</b>	<b>DESCRIPTION</b>	<b>CODE</b>	<b>Kw.</b>	<b>FRAME</b>	<b>SPIGOT</b>	
69H-AH30100200	1	160/1	HL02	0.25-0.37	71/71	110	
69H-AH30202800	1	200/1	HL05L	0.55-1.50	80/90	130	
69H-AH30302500	1	250/1	HL08/1L	2.20-4.00	100/112	180	
	<b><u>GROUP2</u> ( SPIGOT 36.5 )</b>						
				<b>ELECTRIC MOTOR</b>			
	<b>PUMP GROUP</b>	<b>DESCRIPTION</b>	<b>CODE</b>	<b>Kw.</b>	<b>FRAME</b>	<b>SPIGOT</b>	
69H-AH30203500	2	200/2	HL07/SL	0.55-1.5	80/90	130	
69H-AH30302600	2	250/2	HL09L	2.20-4.00	100/112	180	
69H-AH30400800	2	300/2	HL12	5.50-9.20	132/132	230	
69H-AH15000001	2	350/2	HL15	11.00-22.00	160/180	250	
	<b><u>GROUP3</u> ( SPIGOT 50.8 )</b>						
				<b>ELECTRIC MOTOR</b>			
	<b>PUMP GROUP</b>	<b>DESCRIPTION</b>	<b>CODE</b>	<b>Kw.</b>	<b>FRAME</b>	<b>SPIGOT</b>	
69H-AH15050005	3	250/3	HL11	2.2-4.00	100/112	180	
69H-AH30400900	3	300/3	HL13	5.50-9.00	132/132	230	
69H-AH30509200	3	350/3	HL16	11.00-22.00	160/180	250	
69H-AH15010000	3	400/3	HL/20/1	30.00-30.00	200/200	300	
	<b><u>BELLHOUSINGS; HI-LO PUMPS CBT SERIES</u></b>						
	<b>PUMP GROUP:</b>	<b>DESCRIPTION:</b>	<b>ENGINE</b>	<b>ENGINE P.C.D.</b>	<b>SHAFT:</b>		
68H-BHE112/045A	CBT HI/LO	6.3 / 2.1	GX;120/160/200	90	3/4"		
68H-BHE152/045A	CBT HI/LO	10.9 / 3.6	GX;/240/270/340/390	127	1"		
							
	<b>MATERIAL: ALUMINIUM</b>						
	<b>NOTE: ALL BELLHOUSINGS MACHINED FOR ASSEMBLY</b>						
	<b>NOTE: ABOVE DATA TAKEN FROM METRIC THREE PHASE 4 POLE 50 Hz ELECTRIC</b>						
	<b>PLEASE NOTE: ALL O.E.M. NAMES OR NUMBERS ARE FOR REFERENCE USE ONLY</b>						<b>PAGE J 1</b>

**PILOT BORE BLANK**

	DESCRIPTION	SAE FLANGE	CODE	PILOT BORE	ELECTRIC FRAME	MOTOR K.W.
69H-200-63	200 / 63	3-1/4"	TH1-63X	63	80 / 90	0.55 - 1.5
69H-250-63	250 / 63	3-1/4"	TH2-63X	63	100 / 112	2.2 - 4.00
69H-300-80	300 / 80	3-1/4" / 4"	TH3-80X	80	132 / 132	5.50 - 9.00
69H-350-80	350 / 80	3-1/4" / 4" / 5"	TH4-80X	80	160 / 180	11.00 - 22.00
69H-400-100	400 / 100	4" / 5"	TH15-100X	100	200 / 200	30.00 - 30.00



**MATERIAL: ALUMINIUM**  
**NOTE: ALL BELLHOUSINGS MACHINED FOR ASSEMBLY**  
**NOTE: ABOVE DATA TAKEN FROM METRIC THREE PHASE 4 POLE 50 Hz ELECTRIC MOTORS SPEED 1450 RPM**

Part Number	<b>PUMPS GEAR ALUMINIUM</b>				RETAIL:
	<b>PUMP GROUP 1 SINGLE STAGE 230 Bar Continuous</b>				01-10-2022
	<b>BK P 1 SERIES FROM TAK - BOK</b>				
	<b><u>B.S.P. PORTS</u></b>				
	<b>DESCRIPTION:</b>	<b>cc / rev:</b>	<b>PORTS:</b>	<b>ROTATION:</b>	
70H-P1B0D0-8L3	BKP1 - 0.8	0.8 cc per rev	3/8" BSPP x 3/8" BSPP	C/W	
70H-P1B0D1-1L3	BKP1 - 1.1	1.1 cc per rev	3/8" BSPP x 3/8" BSPP	C/W	
70H-P1B0D1-3L3	BKP1 - 1.3	1.3 cc per rev	3/8" BSPP x 3/8" BSPP	C/W	
70H-P1B0D1-6L3	BKP1 - 1.6	1.6 cc per rev	3/8" BSPP x 3/8" BSPP	C/W	
70H-P1B0D1-8L3	BKP1 - 1.8	1.8 cc per rev	3/8" BSPP x 3/8" BSPP	C/W	
70H-P1B0D2-1L3	BKP1 - 2.1	2.1 cc per rev	3/8" BSPP x 3/8" BSPP	C/W	
70H-P1B0D2-7L3	BKP1 - 2.7	2.7 cc per rev	3/8" BSPP x 3/8" BSPP	C/W	
70H-P1B0D3-2L3	BKP1 - 3.2	3.2 cc per rev	3/8" BSPP x 3/8" BSPP	C/W	
70H-P1B0D3-7L3	BKP1 - 3.7	3.7 cc per rev	3/8" BSPP x 3/8" BSPP	C/W	
70H-P1B0D4-2L3	BKP1 - 4.2	4.2 cc per rev	3/8" BSPP x 3/8" BSPP	C/W	
70H-P1B0D4-8L3	BKP1 - 4.8	4.8 cc per rev	3/8" BSPP x 3/8" BSPP	C/W	
70H-P1B0D5-8L3	BKP1 - 5.8	5.8 cc per rev	3/8" BSPP x 3/8" BSPP	C/W	
70H-P1B0D7-0L3	BKP1 - 7.0	7.0 cc per rev	3/8" BSPP x 3/8" BSPP	C/W	
70H-P1B0D8-0L3	BKP1 - 8.0	8.0 cc per rev	3/8" BSPP x 3/8" BSPP	C/W	
70H-BKP1-S	PUMP GP1 SEAL KIT				
	<b><u>PUMP DISPLACEMENTS</u></b>	<b><u>CONT PRESSURE</u></b>	<b><u>INT PRESSURE</u></b>	<b><u>SPEED RANGE</u></b>	
	0.8 cc per rev	230 bar	250 bar	1000 to 6000	
	1.1 cc per rev	230 bar	250 bar	1000 to 6000	
	1.3 cc per rev	230 bar	250 bar	1000 to 6000	
	1.6 cc per rev	230 bar	250 bar	1000 to 6000	
	1.8 cc per rev	230 bar	250 bar	1000 to 6000	
	2.1 cc per rev	230 bar	250 bar	1000 to 6000	
	2.7 cc per rev	230 bar	250 bar	800 to 6000	
	3.2 cc per rev	210 bar	230 bar	800 to 5000	
	3.7 cc per rev	210 bar	230 bar	800 to 4500	
	4.2 cc per rev	210 bar	230 bar	800 to 4000	
	4.8 cc per rev	190 bar	210 bar	600 to 3500	
	5.8 cc per rev	190 bar	210 bar	600 to 3000	
	7.0 cc per rev	160 bar	180 bar	600 to 2500	
	8.0 cc per rev	160 bar	180 bar	600 to 2100	
	<b><u>TECHNICAL SPECS FOR GROUP 1</u></b>				
	SHAFT 1 : 8 TAPER				
	SMALL O/D 8 mm TO BIG O/D 10 mm				
	OVER 15 mm LENGTH				
	SPIGOT 25,4 mm				
	FLANGE 52.2 X 72 4 BOLT				
	PORTS 3/8" BSPP SUCTION & PRESSURE				
					
	<b>PLEASE NOTE: ALL O.E.M. NAMES OR NUMBERS ARE FOR REFERENCE USE ONLY</b>				<b>PAGE K 1</b>

Part Number	PUMPS GEAR ALUMINIUM					RETAIL:				
						01-10-2022				
	<u>PUMP GROUP 2 SINGLE STAGE</u> 270 Bar Continuous									
	BHP 2 SERIES FROM TAK - BOK									
	<u>B.S.P. PORTS</u>									
	<u>DESCRIPTION:</u>	<u>cc / rev:</u>	<u>B.S.P. PORTS:</u>	<u>ROTATION:</u>	<u>W/P:</u>					
70H-P2B0D04T0L1	BHP 2 B0 D 4 T0 L1	04cc per rev	3/4" BSPP x 1/2" BSPP	C/W	270 Bar					
70H-P2B0D06T0L1	BHP 2 B0 D 6 T0 L1	06cc per rev	3/4" BSPP x 1/2" BSPP	C/W	270 Bar					
70H-P2B0D08T0L1	BHP 2 B0 D 8 T0 L1	08cc per rev	3/4" BSPP x 1/2" BSPP	C/W	270 Bar					
70H-P2B0D10T0L1	BHP 2 B0 D 10 T0 L1	10cc per rev	3/4" BSPP x 1/2" BSPP	C/W	270 Bar					
70H-P2B0D12T0L1	BHP 2 B0 D 12 T0 L1	12cc per rev	3/4" BSPP x 1/2" BSPP	C/W	270 Bar					
70H-P2B0D14T0L1	BHP 2 B0 D 14 T0 L1	14cc per rev	3/4" BSPP x 1/2" BSPP	C/W	250 Bar					
70H-P2B0D16T0L1	BHP 2 B0 D 16 T0 L1	16cc per rev	3/4" BSPP x 1/2" BSPP	C/W	250 Bar					
70H-P2B0D18T0L1	BHP 2 B0 D 18 T0 L1	18cc per rev	3/4" BSPP x 1/2" BSPP	C/W	250 Bar					
70H-P2B0D20T0L1	BHP 2 B0 D 20 T0 L1	20cc per rev	3/4" BSPP x 1/2" BSPP	C/W	220 Bar					
70H-P2B0D22T0L1	BHP 2 B0 D 22 T0 L1	22cc per rev	3/4" BSPP x 1/2" BSPP	C/W	220 Bar					
70H-P2B0D25T0L3	BHP 2 B0 D 25 T0 L3	25 cc per rev	1" BSPP x 3/4" BSPP	C/W	200 Bar					
70H-P2B0D28T0L3	BHP 2 B0 D 28 T0 L3	28cc per rev	1" BSPP x 3/4" BSPP	C/W	180 Bar					
70H-P2B0D30T0L3	BHP 2 B0 D 30 T0 L3	30 cc per rev	1" BSPP x 3/4" BSPP	C/W	160 Bar					
70H-BHP2-S	PUMP SEAL KIT									
	<u>PUMP DISPLACEMENTS</u>	<u>CONT PRESSURE P1</u>	<u>INT PRESSURE P2</u>	<u>SPEED RANGE</u>						
	04 cc per rev	270 bar	285 bar	800 to 4000						
	06 cc per rev	270bar	285 bar	600 to 4000						
	08 cc per rev	270 bar	285 bar	500 to 3500						
	10 cc per rev	270bar	285 bar	500 to 3000						
	12 cc per rev	270 bar	285 bar	500 to 3500						
	14 cc per rev	250 bar	265 bar	500 to 4000						
	16 cc per rev	250 bar	265 bar	500 to 4000						
	18 cc per rev	250 bar	265 bar	400 to 3600						
	20 cc per rev	220 bar	265 bar	400 to 3200						
	22 cc per rev	220 bar	265 bar	400 to 3000						
	25 cc per rev	200 bar	215 bar	400 to 3000						
	28 cc per rev	180 bar	190 bar	400 to 2500						
	30 cc per rev	160 bar	170 bar	400 to 2500						
	<u>TECHNICAL SPECS FOR GROUP 2:</u>									
	SHAFT 1 : 8 TAPER SMALL O/D 15 mm TO BIG O/D 17 mm OVER 18 mm LENGTH									
	SPIGOT 36,5 mm									
	FLANGE 96,2 X 71,5 4 BOLT									
	ROTATION CHANGE SWOP INTERNALS									
	CONTINUOUS MAX PRESSURE P1									
	INTERMITTENT MAX PRESSURE P2 20Sec									
										
	<b>PLEASE NOTE: ALL O.E.M. NAMES OR NUMBERS ARE FOR REFERENCE USE ONLY</b>					<b>PAGE K 2</b>				



Part Number	<b>PUMPS GEAR ALUMINIUM</b>				RETAIL:
					01-10-2022
	<b><u>PUMP GROUP 2 SINGLE STAGE</u> 270 Bar Continuous</b>				
	<b><u>BHP 2 SERIES FROM TAK - BOK</u></b>				
	<b><u>DIAMOND PORTS</u></b>				
	<b><u>DESCRIPTION:</u></b>	<b><u>cc / rev:</u></b>	<b><u>DIAMOND</u></b>	<b><u>PORTS:</u></b>	<b><u>ROTATION:</u></b>
70H-P2B0D04T0E0	BHP 2 B0 D 4 T0 E0	04cc per rev	13mm PCD 30 mm x 13 mm PCD 30 mm		C/W
70H-P2B0D06T0E0	BHP 2 B0 D 6 T0 E0	06cc per rev	13mm PCD 30 mm x 13 mm PCD 30 mm		C/W
70H-P2B0D08T0E0	BHP 2 B0 D 8 T0 E0	08cc per rev	13mm PCD 30 mm x 13 mm PCD 30 mm		C/W
70H-P2B0D10T0E0	BHP 2 B0 D 10 T0 E0	10cc per rev	13mm PCD 30 mm x 13 mm PCD 30 mm		C/W
70H-P2B0D12T0E1	BHP 2 B0 D 12 T0 E1	12cc per rev	13mm PCD 30 mm x 20 mm PCD 40 mm		C/W
70H-P2B0D14T0E1	BHP 2 B0 D 14 T0 E1	14cc per rev	13mm PCD 30 mm x 20 mm PCD 40 mm		C/W
70H-P2B0D16T0E1	BHP 2 B0 D 16 T0 E1	16cc per rev	13mm PCD 30 mm x 20 mm PCD 40 mm		C/W
70H-P2B0D18T0E1	BHP 2 B0 D 18 T0 E1	18cc per rev	13mm PCD 30 mm x 20 mm PCD 40 mm		C/W
70H-P2B0D20T0E1	BHP 2 B0 D 20 T0 E1	20cc per rev	13mm PCD 30 mm x 20 mm PCD 40 mm		C/W
70H-P2B0D22T0E1	BHP 2 B0 D 22 T0 E1	22cc per rev	13mm PCD 30 mm x 20 mm PCD 40 mm		C/W
70H-P2B0D25T0E1	BHP 2 B0 D 25 T0 E1	25cc per rev	13mm PCD 30 mm x 20 mm PCD 40 mm		C/W
70H-P2B0D28T0E1	BHP 2 B0 D 28 T0 E1	28cc per rev	13mm PCD 30 mm x 20 mm PCD 40 mm		C/W
70H-P2B0D30T0E1	BHP 2 B0 D 30 T0 E1	30cc per rev	13mm PCD 30 mm x 20 mm PCD 40 mm		C/W
70H-BHP2-S	PUMP SEAL KIT				
	<b><u>PUMP DISPLACEMENTS</u></b>	<b><u>CONT PRESSURE P1</u></b>	<b><u>INT PRESSURE P2</u></b>	<b><u>SPEED RANGE</u></b>	
	04 cc per rev	270 bar	285 bar	800 to 4000	
	06 cc per rev	270bar	285 bar	600 to 4000	
	08 cc per rev	270 bar	285 bar	500 to 3500	
	10 cc per rev	270bar	285 bar	500 to 3000	
	12 cc per rev	270 bar	285 bar	500 to 3500	
	14 cc per rev	250 bar	265 bar	500 to 4000	
	16 cc per rev	250 bar	265 bar	500 to 4000	
	18 cc per rev	250 bar	265 bar	400 to 3600	
	20 cc per rev	220 bar	265 bar	400 to 3200	
	22 cc per rev	220 bar	265 bar	400 to 3000	
	25 cc per rev	200 bar	215 bar	400 to 3000	
	28 cc per rev	180 bar	190 bar	400 to 2500	
	30 cc per rev	160 bar	170 bar	400 to 2500	
	<b><u>TECHNICAL SPECS FOR GROUP 2 :</u></b>				
	SHAFT 1 : 8 TAPER SMALL O/D 15 mm TO BIG O/D 17 mm OVER 18 mm LENGTH				
	SPIGOT 36,5 mm				
	FLANGE 96,2 X 71,5 4 BOLT				
	ROTATION CHANGE SWOP INTERNALS				
	CONTINUOUS MAX PRESSURE P1				
	INTERMITTENT MAX PRESSURE P2 20Sec				
					
	<b>PLEASE NOTE: ALL O.E.M. NAMES OR NUMBERS ARE FOR REFERENCE USE ONLY</b>				<b>PAGE K 3</b>

Part Number	<b>PUMPS GEAR ALUMINIUM</b>			RETAIL:
				30-11-2023
	<b><u>PUMP GROUP 2 SINGLE STAGE</u> 270 Bar Continuous</b>			
	<b><u>BHP 2 SERIES FROM TAK - BOK</u></b>			
	<b><u>BOSCH SINGLE : SPIGOT 80 mm MOUNT 4 BOLT TAPER 1:5</u></b>			
	<b><u>DESCRIPTION:</u></b>	<b><u>cc/rev:</u></b>	<b><u>CW / CCW</u></b>	
70H-P2B2D04T1F0	BHP2 B2 D 4 T1 F0	04cc per rev	0510 225 006 / 306	
70H-P2B2D06T1F0	BHP2 B2 D 6 T1 F0	06cc per rev	0510 235 006 / 306	
70H-P2B2D08T1F1	BHP2 B2 D 8 T1 F1	08cc per rev	0510 425 009 / 307	
70H-P2B2D12T1F1	BHP2 B2 D 12 T1 F1	12cc per rev	0510 525 009 / 311	
70H-P2B2D14T1F1	BHP2 B2 D 14 T1 F1	14cc per rev	0510 525 018 / 319	
70H-P2B2D16T1F1	BHP2 B2 D 16 T1 F1	16cc per rev	0510 625 022 / 315	
70H-P2B2D18T1F1	BHP2 B2 D 18 T1 F1	18cc per rev	0510 625 013 / 314	
70H-P2B2D22T1F1	BHP2 B2 D 22 T1 F1	22cc per rev	0510 725 030 / 330	
	<b><u>DEUTZ SINGLE : SPIGOT 50 mm MOUNT 2 BOLT TAPER 1:5</u></b>			
	<b><u>DESCRIPTION:</u></b>	<b><u>cc/rev:</u></b>	<b><u>CCW / CW</u></b>	
70H-P2Q1S04T1F0	BHP2 Q1 S 4 T1 F0	04cc per rev	0510 215 309 / 009	
70H-P2Q1S06T1F0	BHP2 Q1 S 6 T1 F0	06cc per rev	0510 315 307 / 006	
70H-P2Q1S08T1F1	BHP2 Q1 S 8 T1 F1	08cc per rev	0510 415 316 / 010	
70H-P2Q1S12T1F1	BHP2 Q1 S 12 T1 F1	12cc per rev	0510 515 309 / 007	
70H-P2Q1S14T1F1	BHP2 Q1 S 14 T1 F1	14cc per rev	0510 515 316 / 018	
70H-P2Q1S16T1F1	BHP2 Q1 S 16 T1 F1	16cc per rev	0510 615 317 / 010	
70H-P2Q1S18T1F1	BHP2 Q1 S 18 T1 F1	18cc per rev	0510 615 318 / 005	
70H-P2Q1S22T1F1	BHP2 Q1 S 22 T1 F1	22cc per rev	0510 715 306	
	<b><u>DEUTZ DOUBLE : SPIGOT 50 mm MOUNT 2 BOLT TAPER 1:5</u></b>			
	<b><u>DESCRIPTION:</u></b>	<b><u>cc/rev:</u></b>	<b><u>CCW / CW</u></b>	
70H-P2Q1S-16-12	BHP2 Q1 S 16-12 T1 F1	16cc / 12cc per rev	0510 665 335 /	
70H-P2Q1S-22-14	BHP2 Q1 S 22-14 T1 F1	22cc / 14cc per rev	0510 765 309 /	
70H-P2Q1S-22-16	BHP2 Q1 S 22-16 T1 F1	22cc / 16cc per rev	0510 765 310 /	
	<b><u>BOSCH OUTBOARD BEARING : PUMP SINGLE ROTATION</u></b>			
	<b><u>DESCRIPTION:</u></b>	<b><u>cc/rev:</u></b>	<b><u>CCW / CW</u></b>	
70H-P2B3S8T1F1	BHP2 Q3 S 8 T1 F1	08cc per rev	0510 445 300 / 001	
70H-P2B3S12T1F1	BHP2 Q3 S 12 T1 F1	12cc per rev	0510 545 300 / 001	
	<b><u>OPTIONAL SPARES:</u></b>			
70H-BHP2-S	PUMP SEAL KIT			
70H-BHM2-S	MOTOR SEAL KIT			
70H-BHP2-OUTB-S	PUMP SEAL KIT OUTBOARD BEARING TYPE			
	<b><u>TECHNICAL SPECS FOR GROUP 2:</u></b>			
	STANDARD SHAFT : 1 : 5 TAPER SMALL OD 14 mm TO BIG OD 17 mm OVER 17 mm LENGTH			
	OUTBOARD SHAFT : 1 : 5 TAPER SMALL OD 16.3 mm TO BIG OD 20 mm OVER 20 mm LENGTH			
	BOSCH SPIGOT 80 mm FLANGE 100 X 72 4 BOLT MOUNT			
	DEUTZ SPIGOT 50 mm FLANGE 60 X 60 2 BOLT MOUNT			



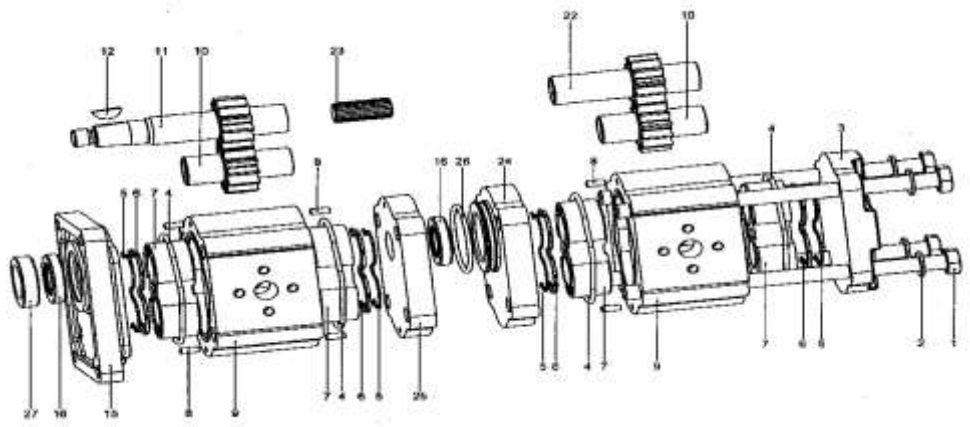

Part Number	<b>PUMPS GEAR ALUMINIUM</b>					RETAIL:
						01-10-2022
	<b><u>PUMP GROUP 2 SINGLE STAGE</u> 270 Bar Continuous</b>					
	<b><u>BHP 2 * / * SERIES FROM TAK - BOK</u></b>					
	<b>MAKE UP ANY OF THE BELOW COMBINATIONS BY CHOOSING THE ADDED PUMP DISPLACEMENTS</b>					
	<b>DRIVE SHAFT LOAD CAPACITY MUST NOT BE EXCEEDED, PHONE THE EXPERTS AND WE WILL ADVISE.</b>					
	<b><u>B.S.P. PORTS</u></b>					
	<b><u>DESCRIPTION:</u></b>	<b><u>cc / rev:</u></b>	<b><u>B.S.P. PORTS:</u></b>	<b><u>ROTATION:</u></b>	<b><u>W/P:</u></b>	
70H-P2B0X-04-XX	BHP2 B0 X4-XX	04 - ** cc per rev	3/4" BSPP x 1/2" BSPP	C/W	270 Bar	
70H-P2B0X-06-XX	BHP2 B0 X6-XX	06 - ** cc per rev	3/4" BSPP x 1/2" BSPP	C/W	270 Bar	
70H-P2B0X-08-XX	BHP2 B0 X8-XX	08 - ** cc per rev	3/4" BSPP x 1/2" BSPP	C/W	270 Bar	
70H-P2B0X-10-XX	BHP2 B0 X10-XX	10 - ** cc per rev	3/4" BSPP x 1/2" BSPP	C/W	270 Bar	
70H-P2B0X-12-XX	BHP2 B0 X12-XX	12 - ** cc per rev	3/4" BSPP x 1/2" BSPP	C/W	270 Bar	
70H-P2B0X-14-XX	BHP2 B0 X14-XX	14 - ** cc per rev	3/4" BSPP x 1/2" BSPP	C/W	250 Bar	
70H-P2B0X-16-XX	BHP2 B0 X16-XX	16 - ** cc per rev	3/4" BSPP x 1/2" BSPP	C/W	250 Bar	
70H-P2B0X-18-XX	BHP2 B0 X18-XX	18 - ** cc per rev	3/4" BSPP x 1/2" BSPP	C/W	250 Bar	
70H-P2B0X-20-XX	BHP2 B0 X20-XX	20 - ** cc per rev	3/4" BSPP x 1/2" BSPP	C/W	220 Bar	
70H-P2B0X-22-XX	BHP2 B0 X22-XX	22 - ** cc per rev	3/4" BSPP x 1/2" BSPP	C/W	220 Bar	
70H-P2B0X-25-XX	BHP2 B0 X25-XX	25 - ** cc per rev	1" BSPP x 3/4" BSPP	C/W	200 Bar	
70H-P2B0X-28-XX	BHP2 B0 X28-XX	28 - ** cc per rev	1" BSPP x 3/4" BSPP	C/W	180 Bar	
70H-P2B0X-30-XX	BHP2 B0 X30-XX	30 - ** cc per rev	1" BSPP x 3/4" BSPP	C/W	160 Bar	
70H-BHP2-S-D	PUMP DOUBLE SEAL KIT					
	<b><u>PUMP DISPLACEMENTS</u></b>	<b><u>CONT PRESSURE P1</u></b>	<b><u>INT PRESSURE P2</u></b>	<b><u>SPEED RANGE</u></b>		
	04 cc per rev	270 bar	285 bar	800 to 4000		
	06 cc per rev	270bar	285 bar	600 to 4000		
	08 cc per rev	270 bar	285 bar	500 to 3500		
	10 cc per rev	270bar	285 bar	500 to 3000		
	12 cc per rev	270 bar	285 bar	500 to 3500		
	14 cc per rev	250 bar	265 bar	500 to 4000		
	16 cc per rev	250 bar	265 bar	500 to 4000		
	18 cc per rev	250 bar	265 bar	400 to 3600		
	20 cc per rev	220 bar	265 bar	400 to 3200		
	22 cc per rev	220 bar	265 bar	400 to 3000		
	25 cc per rev	200 bar	215 bar	400 to 3000		
	28 cc per rev	180 bar	190 bar	400 to 2500		
	30 cc per rev	160 bar	170 bar	400 to 2500		
	<b><u>TECHNICAL SPECS FOR GROUP 2 BHP 2 * / * SERIES :</u></b>					
	SHAFT 1 : 8 TAPER SMALL O/D 15 mm TO BIG O/D 17 mm OVER 18 mm LENGTH					
	SPIGOT 36,5 mm					
	FLANGE 96,2 X 71,5 4 BOLT					
	ROTATION CHANGE SWOP INTERNALS					
	CONTINUOUS MAX PRESSURE P1					
	INTERMITTENT MAX PRESSURE P2 20Sec					
						
	<b>PLEASE NOTE: ALL O.E.M. NAMES OR NUMBERS ARE FOR REFERENCE USE ONLY</b>					<b>PAGE K 5</b>

Part Number	<b>MOTOR GEAR ALUMINIUM</b>					RETAIL:
						01-10-2022
	<b>GROUP 2 BI ROTATION MOTORS FROM TAK - BOK</b>					
	<b>BHM 2 B0 SERIES: 200 Bar Continuous</b>					
	<b>SHAFT 1 ; 8 TAPER SPIGOT 36.4mm MOUNT 4 BOLT 1/4" BSPP CASE DRAIN ON P.E.C.</b>					
	<b>DESCRIPTION:</b>	<b>cc / rev:</b>	<b>B.S.P. PORTS:</b>	<b>ROTATION:</b>	<b>W/P:</b>	
70H-M2B0R06T0L0	BHM 2 B0 R 6 T0 L0-Q1	06cc per rev	1/2" BSPP x 1/2" BSPP	B / I	200 Bar	
70H-M2B0R08T0L0	BHM 2 B0 R 8 T0 L0-Q1	08cc per rev	1/2" BSPP x 1/2" BSPP	B / I	200 Bar	
70H-M2B0R10T0L0	BHM 2 B0 R 10 T0 L0-Q1	10cc per rev	1/2" BSPP x 1/2" BSPP	B / I	200 Bar	
70H-M2B0R12T0L0	BHM 2 B0 R 12 T0 L0-Q1	12cc per rev	1/2" BSPP x 1/2" BSPP	B / I	200 Bar	
70H-M2B0R14T0L0	BHM 2 B0 R 14 T0 L0-Q1	14cc per rev	1/2" BSPP x 1/2" BSPP	B / I	200 Bar	
70H-M2B0R16T0L0	BHM 2 B0 R 16 T0 L0-Q1	16cc per rev	1/2" BSPP x 1/2" BSPP	B / I	200 Bar	
70H-M2B0R18T0L0	BHM 2 B0 R 18 T0 L0-Q1	18cc per rev	1/2" BSPP x 1/2" BSPP	B / I	200 Bar	
70H-M2B0R20T0L0	BHM 2 B0 R 20 T0 L0-Q1	20cc per rev	1/2" BSPP x 1/2" BSPP	B / I	200 Bar	
70H-M2B0R22T0L0	BHM 2 B0 R 22 T0 L0-Q1	23cc per rev	1/2" BSPP x 1/2" BSPP	B / I	200 Bar	
	<b>BHM 2 B2 SERIES:</b>					
	<b>SHAFT 1 ; 5 TAPER SPIGOT 80mm MOUNT 4 BOLT 1/4" BSPP CASE DRAIN ON P.E.C.</b>					
	<b>DESCRIPTION:</b>	<b>cc / rev:</b>	<b>B.S.P. PORTS:</b>	<b>ROTATION:</b>	<b>W/P:</b>	
70H-M2B2R06T1L0	BHM 2 B2 R 6 T1 L0-Q1	06cc per rev	1/2" BSPP x 1/2" BSPP	B / I	200 Bar	
70H-M2B2R08T1L0	BHM 2 B2 R 8 T1 L0-Q1	08cc per rev	1/2" BSPP x 1/2" BSPP	B / I	200 Bar	
70H-M2B2R10T1L0	BHM 2 B2 R 10 T1 L0-Q1	10cc per rev	1/2" BSPP x 1/2" BSPP	B / I	200 Bar	
70H-M2B2R12T1L0	BHM 2 B2 R 12 T1 L0-Q1	12cc per rev	1/2" BSPP x 1/2" BSPP	B / I	200 Bar	
70H-M2B2R14T1L0	BHM 2 B2 R 14 T1 L0-Q1	14cc per rev	1/2" BSPP x 1/2" BSPP	B / I	200 Bar	
	<b>BHM 2 A0 SERIES:</b>					
	<b>SHAFT 16mm SPIGOT 3-1/4" MOUNT 2 BOLT 1/4" BSPP CASE DRAIN ON P.E.C.</b>					
	<b>DESCRIPTION:</b>	<b>cc / rev:</b>	<b>B.S.P. PORTS:</b>	<b>ROTATION:</b>	<b>W/P:</b>	
70H-M2A0R06C0L0	BHM 2 A0 R 6 C0 L0	06cc per rev	1/2" BSPP x 1/2" BSPP	B / I	200 Bar	
70H-M2A0R08C0L0	BHM 2 A0 R 8 C0 L0	08cc per rev	1/2" BSPP x 1/2" BSPP	B / I	200 Bar	
70H-M2A0R10C0L0	BHM 2 A0 R 10 C0 L0	10cc per rev	1/2" BSPP x 1/2" BSPP	B / I	200 Bar	
70H-M2A0R12C0L0	BHM 2 A0 R 12 C0 L0	12cc per rev	1/2" BSPP x 1/2" BSPP	B / I	200 Bar	
70H-M2A0R14C0L0	BHM 2 A0 R 14 C0 L0	14cc per rev	1/2" BSPP x 1/2" BSPP	B / I	200 Bar	
70H-M2A0R18C0L0	BHM 2 A0 R 18 C0 L0	18cc per rev	1/2" BSPP x 1/2" BSPP	B / I	200 Bar	
70H-M2A0R22C0L0	BHM 2 A0 R 22 C0 L0	23cc per rev	1/2" BSPP x 1/2" BSPP	B / I	200 Bar	
	<b>EXTRA CHOICES</b>					
70H-BHM2-S	MOTOR SEAL KIT					
70H-2MFPECB	BI ROTATION PORT END COVER NO CASE DRAIN INTERNAL CHECK VALVES					
70H-2MFPECRP	REAR PORTS; 3/4" BSPP MAX					
70H-2MFPECRF	RELIEF VALVE PORT END COVER 50 - 250 Bar					
	<b>PUMP DISPLACEMENTS</b>	<b>CONT PRESSURE</b>	<b>INT PRESSURE</b>	<b>SPEED RANGE</b>		
	06 cc per rev	270 bar	285 bar	600 to 4000		
	08 cc per rev	270 bar	285 bar	500 to 3500		
	10 cc per rev	270 bar	285 bar	500 to 3000		
	12 cc per rev	270 bar	250 bar	500 to 3500		
	14 cc per rev	250 bar	265 bar	400 to 4000		
	18 cc per rev	250 bar	265 bar	400 to 3600		
	22 cc per rev	220 bar	265 bar	400 to 3000		
						
	3-1/4" SPIGOT	80mm SPIGOT	36,5mm SPIGOT			
	<b>PLEASE NOTE: ALL O.E.M. NAMES OR NUMBERS ARE FOR REFERENCE USE ONLY</b>					
						<b>PAGE K 6</b>

Part Number	PUMPS GEAR ALUMINIUM			RETAIL:
				01-10-2022
	<b><u>GROUP 2 GEAR PUMPS / MOTORS / FLOW DIVIDERS</u></b>			
	<b>MADE TO ORDER OUT OF VIRGIN PARTS 270 Bar Continuous</b>			
	<b><u>SINGLE PUMP DISPLACEMENTS AVAILABLE:</u></b>			
70H-334X-04-08	04cc ; 06cc ; 08cc ;			
70H-334X-10-14	10cc ; 11cc ; 14cc			
70H-334X-16-23	16cc ; 19cc ; 23cc			
70H-334X-27-33	27cc ; 31cc ; 33cc			
	<b><u>TANDEM PUMP DISPLACEMENTS AVAILABLE:</u> ( ADD PRICE TO SINGLE PUMP'S PRICE )</b>			
70H-334XD-04-08	04cc ; 06cc ; 08cc ;			
70H-334XD-10-14	10cc ; 11cc ; 14cc			
70H-334XD-16-23	16cc ; 19cc ; 23cc			
70H-334XD-27-33	27cc ; 31cc ; 33cc			
	<b><u>(CODE) CHOICE OF PUMP SPIGOTS:</u></b>			
70H-3345041212	(33) GROUP 2	36,4mm SPIGOT	4-BOLT MOUNTING	
70H-3345041213	(34) BOSCH	80mm SPIGOT	4-BOLT MOUNTING	
70H-3345051212	(39) DEUTZ	50mm SPIGOT	2-BOLT THRU-MOUNTING ( 10 & 4 )	
70H-3345021225	(93) SAE A	3"-1/4" SPIGOT	2-BOLT MOUNTING	
70H-3345021214	(96) SAE B	4" SPIGOT	2-BOLT MOUNTING	
70H-33450512SP	(37) NEUSE	50mm SPIGOT	2-BOLT THRU-MOUNTING ( 8 & 2 )	
70H-3345050212	(38) (36) IH	52mm SPIGOT	2-BOLT THRU-MOUNTING ( 10 & 4 ) (8&2)	
70H-3345021229	(XX) MASSEY	52,3mm SPIGOT	2-BOLT THRU-MOUNTING	
70H-3345021225	(xx) CAT	X" SPIGOT	X-BOLT MOUNTING	
70H-3345029216	(xx) PERKINS	X" SPIGOT	X-BOLT MOUNTING	
	<b><u>(CODE) CHOICE OF PUMP SHAFTS:</u></b>			
70H-33419XX611	(86) 1 : 8	TAPER SHAFT	SMALL O/D 15mm TO BIG O/D 17mm OVER 18mm	
70H-33419XX610	(85) 1 : 5	TAPER SHAFT	SMALL O/D 14mm TO BIG O/D 17mm OVER 17mm	
70H-33412XX210	(96) 9	TOOTH SPLINE SAE A	O/D 15,5mm	
70H-33412XX710	(81) 9	TOOTH SPLINE DIN 5482	O/D 16,5mm	
70H-33417XX210	(97) 5/8"	P / KEY SHAFT	O/D 15,8mm	
70H-33417XX310	(24) 3/4"	P / KEY SHAFT	O/D 19mm	
70H-33417XX205	(XX) 16mm	P / KEY SHAFT	O/D 16mm	
70H-33417XX214	(P ) 11/16"	KEY SHAFT WITH THREAD	O/D 17,4mm	
70H-33412XX910	(94) 10	TOOTH SPLINE SHAFT	O/D 17mm	
70H-33412XX310	(92) 11	TOOTH SPLINE SHAFT	O/D 18.5mm	
70H-3321000011	(XX) CAT	14 TOOTH OUTBOARD	O/D 31mm	
70H-33413XX510	(XX) TANG DRIVE	P / SHAFT	O/D 18mm W/D 8mm	
70H-33412XX711	(XX) SPLINE TOOTH SPLINE KALMAR		O/D 7/8"	
				
<b>PLEASE NOTE: ALL O.E.M. NAMES OR NUMBERS ARE FOR REFERENCE USE ONLY</b>				<b>PAGE K 7</b>



Part Number	<b>PUMPS GEAR ALUMINIUM</b>	RETAIL:
		<b>15-02-2023</b>
	<b><u>GROUP 2 PUMPS MOTORS &amp; FLOW DIVIDERS MADE TO ORDER</u></b>	
	<b><u>ADD ON TO BASE PRICE OF PUMP OR MOTOR</u></b>	
70H-3323000110	MOTOR CONVERSION BI-ROTATIONAL WITH 1/4" BSPP CASE DRAIN	
70H-3323020910	MOTOR CONVERSION BI-ROTATIONAL WITH CHECK VALVES NO CASE DRAIN	
70H-IMRC67B1	MOTOR CONVERSION BI-ROTATIONAL WITH 1/4" BSPP CASE DRAIN AND SINGLE RELIEF	
	<b><u>CHOICE OF PORT END COVERS:</u></b>	
70H-3509611071	PRIORITY FLOW DIVIDER WITH RELIEF VALVE 1 : 30 LITRES REG FLOW REAR PORTS	
70H-3509612030	PRIORITY FLOW DIVIDER WITH RELIEF VALVE 1 : 30 LITRES REG FLOW SIDE PORTS	
70H-3329414017	RELIEF VALVE INTERNAL DUMP 250 BAR MAX	
70H-3323030110	REAR PORTS AVAILABLE 1" & 1/2" BSPP / SAE "O" OR 3/4" MAX BOTH PORTS	
	<b><u>CHOICE OF SHAFT END COVERS:</u></b>	
63H-BU12020007	V BELT PULLEY SUPPORT GROUP 2 PUMP 1 : 8 TAPER TO A 22 mm PARALLEL KEY SHAFT	
70H-TK-STSU-ZFD	OUTBOARD BEARING 80mm SPIGOT FOR PULLEY DRIVE 1 : 5 TAPER	
	<b><u>CHOICE OF FLOW DIVIDERS:</u></b>	
	FLOW DIVIDERS ( <b>ADD UP STAGES OF SINGLE MOTOR DISPLACEMENT PRICES</b> )	
	<b><u>SPECIAL REQUESTS</u></b>	
70H-LAB001	SEALED MULTIPLE UNITS PER SECTION	
70H-LAB002	UNSEALED MULTIPLE UNITS P511 TO P3 SEALED FOR ; 0.8 - 1.2 - 1.6 - 2.5 - 3.6 - 4.8	
70H-LAB003	TWIN SHAFT SINGLE PUMP FOR FAN ON REAR	
	<b><u>LABOUR ADD ON CHARGES</u></b>	
70H-LAB004	LABOUR TO MODIFY OLD PRIORITY FLOW DIVIDER TO FIT P11	
70H-LAB005	LABOUR TO MODIFY S. E. C.	
70H-LAB006	LABOUR TO DRILL AND TAP SHAFT	
70H-LAB007	LABOUR TO DRILL PRIORITY FLOW DIVIDER ORIFICE	
70H-LAB008	LABOUR TO TEST PUMP / MOTOR	
70H-BHP2-S	PUMP SEAL KIT	
70H-BHP2-S-D	PUMP DOUBLE SEAL KIT	
70H-BHM2-S	MOTOR SEAL KIT	
70H-BHP2-OUTB-S	PUMP SEAL KIT OUTBOARD BEARING TYPE	
	<b>POPULAR SPIGOTS</b>	
		
	SPIGOT 36,4mm	SPIGOT 80mm
		SPIGOT 69,8mm
		
	SPIGOT 52,3mm	SPIGOT 3" & 4"
		SPIGOT 50mm
	<b>PLEASE NOTE: ALL O.E.M. NAMES OR NUMBERS ARE FOR REFERENCE USE ONLY</b>	

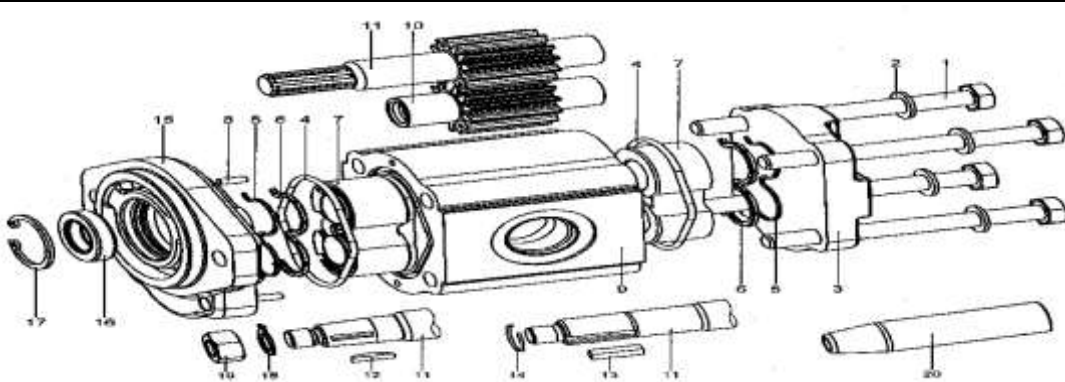

Part Number	PUMPS GEAR ALUMINIUM		RETAIL:
			01-10-2022
	<b>GROUP 3 PUMPS MOTORS &amp; FLOW DIVIDERS MADE TO ORDER</b>		
	MADE TO ORDER OUT OF VIRGIN PARTS		
	<u>SINGLE PUMP DISPLACEMENTS AVAILABLE:</u>		
71H-333X-14-19	14cc ; 16cc ; 19cc ;		
71H-333X-23-28	23cc ; 25cc ; 28cc ;		
71H-333X-33-44	33cc ; 38cc ; 44cc ;		
71H-333X-50-65	50cc ; 52cc ; 65cc		
	<u>TANDEM PUMP DISPLACEMENTS AVAILABLE: ( ADD PRICE TO SINGLE PUMP'S PRICE )</u>		
71H-333D-14-19	14cc ; 16cc ; 19cc ;		
71H-333D-23-28	23cc ; 25cc ; 28cc ;		
71H-333D-33-44	33cc ; 38cc ; 44cc ;		
71H-333D-50-65	50cc ; 52cc ; 65cc		
	<u>PUMP SPIGOT OPTIONS:</u>		
71H-3335040215	(87) GROUP 3	50mm SPIGOT	4-BOLT MOUNTING
71H-3335020212	(93) SAE A	3 1/4" SPIGOT	2-BOLT MOUNTING
71H-3335020213	(96) SAE B	4" SPIGOT	2 BOLT MOUNTING
71H-3335040216	(86) EURO	105mm SPIGOT	4 BOLT MOUNTING
	<u>SHAFT OPTIONS:</u>		
71H-33329XX783	(59)	1 : 8 TAPER SHAFT SMALL O/D 19mm TO BIG O/D 22mm OVER 22mm LENGTH	
71H-33329XX784	(57)	1 : 5 TAPER SHAFT SMALL O/D 13.5mm TO BIG O/D 17.4mm OVER 20mm LENGTH	
71H-33329XX951	(66)	7/8" PARALLEL KEY SHAFT	O/D 22.2mm
71H-33329XX990	(67)	1" PARALLEL KEY SHAFT	O/D 25.4mm
71H-33329XX450	(65)	13 TOOTH SPLINE SHAFT SAE B	O/D 22.2mm
71H-33329XX490	(100)	15 TOOTH SPLINE SHAFT SAE B B	O/D 24.97mm
	<u>POSSIBLE OPTIONS TO BE ADDED TO PUMPS &amp; MOTORS:</u>		
71H-3333030110	MOTOR CONVERSION BI-ROTATIONAL WITH 1/4" BSPP CASE DRAIN		
71H-333BICHV	MOTOR CONVERSION BI-ROTATIONAL WITH CHECK VALVES NO CASE DRAIN		
71H-3509713028	PRIORITY FLOW DIVIDER WITH RELIEF VALVE 5 : 38 LITRES REG FLOW		
71H-3333030110	REAR PORTS AVAILABLE MOTOR TYPE 1" MAX BSPP OR S.A.E.		
71H-3333031110	REAR PORTS AVAILABLE SPECIAL TYPE 1 1/2" MAX BSPP OR S.A.E.		
71H-3333030108	RELIEF VALVE INTERNAL DUMP 250 BAR MAX		
	<u>CHOICE OF FLOW DIVIDERS:</u>		
71H-M17FD	FLOW DIVIDERS ( ADD UP STAGES OF SINGLE MOTOR DISPLACEMENT PRICES )		
71H-P17-P11	STEP DOWN ADAPTOR P17 - P11		
71H-P17-P11S	STEP DOWN ADAPTOR P17 - P11 SEPARATE OILS LABOUR		
71H-LAB009	LABOUR TO DRILL AND TAP SHAFT		
71H-LAB010	DRILL PRIORITY FLOW DIVIDER ORIFICE		
71H-LAB011	TEST PUMP / MOTOR		
71H-3P17-S	SEAL KIT PUMP		
71H-3M17-S	SEAL KIT MOTOR		
			
	PLEASE NOTE: ALL O.E.M. NAMES OR NUMBERS ARE FOR REFERENCE USE ONLY		

**1FDF SERIES FLOW DIVIDER UP TO 4 STAGES**

DISPL	L P M	L P M	INLET	OUTLET	DRAIN	CONT DIFF	MAXIMUM
CC / REV	MIN / FLOW	MAX / FLOW	PORT	PORT	PORT	PRESSURE	OUTLET PRESS
GEAR SET	GEAR SET	GEAR SET	BSPP	BSPP	BSPP	INLET/OUTLET	ANY SECTION

72H-1FDF1-6	1.6 cc	3	6.4	1/2"	1/2"	NONE	124 Bar	240 Bar
72H-1FDF4-2	4.2 cc	9.5	18.9	1/2"	1/2"	NONE	124 Bar	240 Bar

**TECHNICAL SPECS**

COMBINER TYPE; REVERSIBLE FLOW WITH BUILT IN RELIEFS TO SYNCHRONISE  
 EACH PUMP HOUSING HAS SEPARATE BUILT IN RELIEF VALVES NO TANK LINE REQUIRED

**2FDF SERIES FLOW DIVIDER UP TO 8 STAGES**

DISPLACE	L P M	L P M	INLET	OUTLET	DRAIN	CONT DIFF	MAXIMUM
CC / REV	MIN / FLOW	MAX / FLOW	PORT	PORT	PORT	PRESSURE	OUTLET PRESS
GEAR SET	GEAR SET	GEAR SET	BSPP	BSPP	BSPP	INLET/OUTLET	ANY SECTION

72H-2FDF06	6cc	3	18	3/4"	1/2"	3/8"	220	250
72H-2FDF08	8cc	4	22	3/4"	1/2"	3/8"	220	250
72H-2FDF11	11cc	5.5	27	3/4"	1/2"	3/8"	220	250
72H-2FDF14	14cc	7	34	3/4"	1/2"	3/8"	200	220
72H-2FDF17	17cc	8.5	37	3/4"	1/2"	3/8"	220	250
72H-2FDF25	25cc	12	53	3/4"	1/2"	3/8"	200	220

**TECHNICAL SPECS**

COMBINER TYPE; REVERSIBLE FLOW WITH BUILT IN RELIEFS TO SYNCHRONISE  
 EACH PUMP HOUSING HAS SEPARATE BUILT IN RELIEF VALVE AND HAS TO BE PIPED TO A  
 TANK LINE IF YOU NEED IT TO SYNCHRONISE



**2FDF SERIES FLOW DIVIDER**







**1FDF SERIES FLOW DIVIDER**



Part Number	<b>TAK - BOK HI / LOW GEAR PUMPS</b>							RETAIL:	
								01-10-2022	
<b><u>CBT SERIES; HI / LOW PUMPS FOR PETROL ENGINE FITMENT</u></b>									
<b><u>TECHNICAL SPECS ON CBT SERIES 210 Bar</u></b>									
	SHAFT	SPIGOT	MOUNT		SUCTION	PRESSURE	ROTATION		
	1/2" P/Key	45.25mm	4 BOLT 50.08 X 50.08		25.4mm PIPE	1/2" NPT	C/W		
	5/8" P/KEY	3-1/4"	2 BOLT		1" NPT	3/4" NPT	C/W		
NOTE; TO WORK OUT Kw REQUIRED, YOU ONLY NEED TO TAKE THE HIGHEST VALUE IN Kw AND THEN USE COLUMN G OR COLUMN J , NOT BOTH									
<b><u>PUMP CBT 6.3 - 2.1</u></b>									
	A	B	C	D	E	F	G	H	J
	PUMP	CC/REV	CC/REV	Bar	Bar	FLOW	MAX K.w.	FLOW	MAX K.w.
	R P M	HI	LOW	HI	LOW	COMBINED	REQUIRED	LOW	REQUIRED
72H-C-6-3-2-1	1450	6.3	2.1	210	30 - 60	12 LITER	0.7 - 1.4	3 LITER	1.2
72H-C-6-3-2-1	2500	6.3	2.1	210	30 - 60	21 LITER	1.2 - 2.5	5.3 LITER	2.2
72H-C-6-3-2-1	3600	6.3	2.1	210	30 - 60	30 LITER	1.8 - 3.5	7.6 LITER	3.3
SUGGESTED PETROL ENGINE GX200									
<b><u>PUMP CBT 10.9 - 3.6</u></b>									
	A	B	C	D	E	F	G	H	J
	PUMP	CC/REV	CC/REV	Bar	Bar	FLOW	MAX K.w.	FLOW	MAX K.w.
	R P M	HI	LOW	HI	LOW	COMBINED	REQUIRED	LOW	REQUIRED
72H-C-10-9-3-6	1450	10.9	3.6	210	30 - 60	21 LITER	1.2 - 2.5	5.2 LITER	2.1
72H-C-10-9-3-6	2500	10.9	3.6	210	30 - 60	36 LITER	2.2 - 4.3	9 LITER	3.8
72H-C-10-9-3-6	3600	10.9	3.6	210	30 - 60	52 LITER	3.1 - 6.1	12.9 LITER	5.3
SUGGESTED PETROL ENGINE GX270									
<b><u>PUMP CBT 22.9 - 7.6</u></b>									
	A	B	C	D	E	F	G	H	J
	PUMP	CC/REV	CC/REV	Bar	Bar	FLOW	MAX K.w.	FLOW	MAX K.w.
	R P M	HI	LOW	HI	LOW	COMBINED	REQUIRED	LOW	REQUIRED
72H-C-22-9-7-6	1450	22.9	7.6	210	30 - 60	44.2 LITER	2.6 - 5.2	11.0 LITER	4.5
72H-C-22-9-7-6	2500	22.9	7.6	210	30 - 60	76.2 LITER	4.5 - 9	19.0 LITER	8.0
72H-C-22-9-7-6	3600	22.9	7.6	210	30 - 60	109.8 LITER	6.4 - 12.9	27.4 LITER	11.3
SUGGESTED PETROL ENGINE GX630									
<b><u>CYLINDER SHAFT SPEEDS IN SECONDS</u></b>									
	INPUT	SHAFT OUT	SHAFT IN	SHAFT OUT	SHAFT IN	SHAFT OUT	SHAFT IN	SHAFT OUT	SHAFT IN
	FLOW	76.2mm BORE	76.2mm BORE	101.6mm BORE	101.6mm BORE	127mm BORE	127mm BORE	127mm BORE	127mm BORE
	IN	CYLINDER	38mm SHAFT	CYLINDER	50.8mm SHAFT	CYLINDER	50.8mm SHAFT	CYLINDER	50.8mm SHAFT
	LITER	500 mm	500 mm	500m	500 mm	500 mm	500 mm	500 mm	500 mm
	3	45	34	81	61	127	106	127	106
	5.2	26	20	47	35	73	61	73	61
	11	12	9.3	22	17	35	29	35	29
	12.1	11.2	8.4	19.8	14.8	31.3	26.3	31.3	26.3
	21	6.5	4.8	12	8.7	18	15	18	15
	44.2	3	2.3	5.5	4.1	8.6	7.2	8.6	7.2
<b><u>LS-TW LOG SPLITTER VALVE</u></b>									
72H-LS-TW-20F	LS-TW CONTROL VALVE HAND OPERATED WITH ONE WAY DETENT PRESSURE RELEASE DETENT								
	FLOW	PORTS	PORTS	DETENT ONE WAY		SPOOL	MAX		
	RATE	P&T	A&B	PRESSURE RELEASE		TYPE	PRESSURE		
	95 L	3/4" NPT	1/2" NPT	30 - 70 Bar		CYLINDER	210		
72H-LS-TW-S-KIT	LS-TW CONTROL VALVE SEAL KIT								
									
PLEASE NOTE: ALL O.E.M. NAMES OR NUMBERS ARE FOR REFERENCE USE ONLY								PAGE M 2	



Part Number	<b>TAK - BOK HI / LOW GEAR PUMPS</b>						RETAIL:		
							<b>01-10-2022</b>		
<b><u>BHLP1 SERIES: HI / LOW PUMPS FOR ELECTIC MOTOR FITMENT</u></b>									
<b><u>TECHNICAL SPECS ON BHLP SERIES 210 Bar</u></b>									
	SHAFT	SPIGOT	MOUNT	SUCTION	PRESSURE	ROTATION			
	1:8 TAPER Key	25.4 mm	4 BOLT	3/4 "BSPP	1/2 "BSPP	C/W			
<b><u>PUMP BHLP1 BO D 2.1 / 5.8</u></b>									
	A	B	C	D	E	F	G	H	J
	PUMP	CC/REV	CC/REV	Bar	Bar	FLOW	MAX K.w.	FLOW	MAX K.w.
	R P M	HI	LOW	HI	LOW	COMBINED	REQUIRED	LOW	REQUIRED
72H-BHLP2-1-5-8	1450	2.1	5.8	210	30 - 60	11.4 LITER	0.7 - 1.4	3 LITER	1.2
<b><u>PUMP BHLP1 BO D 3.7 / 9.8</u></b>									
	A	B	C	D	E	F	G	H	J
	PUMP	CC/REV	CC/REV	Bar	Bar	FLOW	MAX K.w.	FLOW	MAX K.w.
	R P M	HI	LOW	HI	LOW	COMBINED	REQUIRED	LOW	REQUIRED
72H-BHLP3-7-9-8	1450	9.8	3.7	210	30 - 60	19.5	1.2 - 2.5	5.2 LITER	2.2
NOTE; TO WORK OUT Kw REQUIRED, YOU ONLY NEED TO TAKE THE HIGHEST VALUE IN Kw AND THEN USE COLUMN G OR COLUMN J , NOT BOTH									
<b><u>CYLNDER SHAFT SPEEDS IN SECONDS</u></b>									
	INPUT	SHAFT OUT	SHAFT IN	SHAFT OUT	SHAFT IN	SHAFT OUT	SHAFT IN		
	FLOW	76.2mm BORE	76.2mm BORE	101.6mm BORE	101.6mm BORE	127mm BORE	127mm BORE		
	IN	CYLINDER	38mm SHAFT	CYLINDER	50.8mm SHAFT	CYLINDER	50.8mm SHAFT		
	LITER	500 mm	500 mm	500m	500 mm	500 mm	500 mm		
	3	45	34	81	61	127	106		
	5.2	26	20	47	35	73	61		
	9	15	11	26	20	42	35		
	11.4	12	9.3	22	17	35	29		
	19.5	7	5	12	9	16	23		
	21	6.5	4.8	11	8.7	18	15		
	36	4	3	6	5	10	9		
	76.2			3	2	5	4		
<b><u>LS-TW LOG SPLITTER VALVE</u></b>									
72H-LS-TW-20F	LS-TW CONTROL VALVE HAND OPERATED WITH ONE WAY DETENT PRESSURE RELEASE DETENT								
	FLOW	PORTS	PORTS	DETENT ONE WAY	SPOOL	MAX			
	RATE	P&T	A&B	PRESSURE RELEASE	TYPE	PRESSURE			
	95 L	3/4" NPT	1/2" NPT	30 - 70 Bar	CYLINDER	210			
72H-LS-TW-S-KIT	LS-TW CONTROL VALVE SEAL KIT								
 									
PLEASE NOTE: ALL O.E.M. NAMES OR NUMBERS ARE FOR REFERENCE USE ONLY							<b>PAGE M 3</b>		



Part Number	PUMPS GEAR O. E. M.						RETAIL:
							01-10-2022
	<b>MASSEY</b>						
	<b>MAKE</b>	<b>SERIES</b>	<b>TYPE</b>	<b>MAKE</b>	<b>SERIES</b>	<b>USE</b>	
73H-3349112669	MASSEY	750 / 850	TLD	COMM	PX	STEER / TR/ NO GEAR	
73H-385749Y	MASSEY	750 / A60	TLD	COMM	PX	MAIN (15 SPLINE SHAFT)	
	<b>J C B</b>						
	<b>MAKE</b>	<b>SERIES</b>	<b>TYPE</b>	<b>MAKE</b>	<b>SERIES</b>	<b>USE</b>	
73H-384080H	J C B	3 C X	TLD	COMM	PGP620	MAIN (1" P/ KEY SHAFT)	
73H-7029120016	J C B	3 C X	TLD	COMM	SITE MASTER	MAIN (15 SPLINE SHAFT)	
	<b>NEW HOLLAND</b>						
	<b>MAKE</b>	<b>SERIES</b>	<b>TYPE</b>	<b>MAKE</b>	<b>SERIES</b>	<b>USE</b>	
73H-7029521066	NEW HOLLAND		TLD	COMM			
	<b>MANITOU</b>						
	<b>MAKE</b>	<b>SERIES</b>	<b>TYPE</b>	<b>MAKE</b>	<b>SERIES</b>	<b>USE</b>	
73H-7029522013	MANITOU		FORK LIFT	PGP DOUBLE	OVCON		
73H-5729D	MANITOU		FORK LIFT	PGP / P511			
	<b>VOLVO</b>						
	<b>MAKE</b>	<b>SERIES</b>	<b>TYPE</b>	<b>MAKE</b>	<b>SERIES</b>	<b>USE</b>	
73H-386047X	VOLVO	647	FEL	COMM	PX	STEER	
	<b>FINLEY / POWER SCREEN CRUSHER</b>						
	<b>MAKE</b>	<b>SERIES</b>	<b>TYPE</b>	<b>MAKE</b>	<b>SERIES</b>	<b>USE</b>	
73H-3349219396	FINLEY	CRUSHER	P511	COMM			
	<b>HYSTER</b>						
	<b>MAKE</b>	<b>SERIES</b>	<b>TYPE</b>	<b>MAKE</b>	<b>SERIES</b>	<b>USE</b>	
73H-3349112374	HYSTER FORK		LIFT	COMM	PGP511		
	<b>BELL / JOHN DEER</b>						
	<b>MAKE</b>	<b>SERIES</b>	<b>TYPE</b>	<b>MAKE</b>	<b>SERIES</b>	<b>USE</b>	
73H-3249529049	JOHN DEER	315 SE	TLD	COMMER	P330/P315	MAIN	
	<b>CAT</b>						
	<b>MAKE</b>	<b>SERIES</b>	<b>TYPE</b>	<b>MAKE</b>	<b>SERIES</b>	<b>USE</b>	
73H-387975H	CAT						
73H-3349110016	CAT						
	<b>CASE</b>						
	<b>MAKE</b>	<b>SERIES</b>	<b>TYPE</b>	<b>MAKE</b>	<b>SERIES</b>	<b>USE</b>	
73H-3249110085	CASE	580 G	TLD	COMMER	P330/15	MAIN	
73H-3249120118	CASE	580 K	TLD	COMMER	P330/15/05	MAIN	
73H-3239529084	CASE	580 SLE	TLD	COMMER	P350	MAIN	
73H-3139622461	CASE	W24C	FEL	COMMER		MAIN	
	<b>BOMAG</b>						
	<b>MAKE</b>	<b>SERIES</b>	<b>TYPE</b>	<b>MAKE</b>	<b>DESCRIPTION</b>	<b>USE</b>	
73H-0036110048	BOMAG	212	GEAR	KRACHT	KP2-40-G20AK004DL1	PUMP	
73H-0049350007	BOMAG	212	GEAR	KRACHT	KM2-50-G20AK002DL1	MOTOR	
	<b>J C B 3 C X</b>						<b>MASSY 750</b>
							
	<b>MANITOU</b>						<b>FINLEY</b>
							
	<b>PLEASE NOTE: ALL O.E.M. NAMES OR NUMBERS ARE FOR REFERENCE USE ONLY</b>						<b>PAGE N1</b>

Part Number	<b>FORKLIFT PUMPS</b>				RETAIL: <b>01-10-2022</b>
	<a href="#"><b>TOYOTA</b></a>				
	<a href="#"><b>3 SERIES</b></a>				
74H-TKBFLT325R	<b>3 SERIES</b>	<b>3 TON</b>	<b>5P ENGINE</b>	<b>PETROL - GAS</b>	
	<a href="#"><b>3 SERIES</b></a>				
74H-TKBFLT325R	<b>3 SERIES</b>	<b>1.8 / 3 TON</b>	<b>2J ENGINE</b>	<b>DIESEL</b>	
	<a href="#"><b>3 SERIES</b></a>				
74H-326-T-4-D	<b>3 SERIES</b>	<b>4 TON</b>	<b>2F ENGINE</b>	<b>PETROL - GAS</b>	
74H-326-T-4-P	<b>3 SERIES</b>	<b>4 TON</b>	<b>2H ENGINE</b>	<b>DIESEL</b>	
	<a href="#"><b>4 SERIES</b></a>				
74H-TKBFLT325R	<b>4 SERIES</b>	<b>3 TON</b>	<b>5P ENGINE</b>	<b>PETROL - GAS</b>	
	<a href="#"><b>4 SERIES</b></a>				
74H-TKBFLT325R	<b>4 SERIES</b>	<b>2 / 2.5 TON</b>	<b>2J ENGINE</b>	<b>DIESEL</b>	
	<a href="#"><b>3 / 4 SERIES</b></a>				
74H-332-E-3-1-5	<b>3 / 4 FBRE SERIES</b>	<b>1 / 1.3 / 1.5 / 3 TON</b>	<b>MOTOR</b>	<b>ELECTRIC</b>	
	<a href="#"><b>5 SERIES</b></a>				
74H-TKBFLT325R	<b>5 SERIES</b>	<b>3 TON</b>	<b>5P ENGINE</b>	<b>PETROL - GAS</b>	
	<a href="#"><b>5 SERIES</b></a>				
74H-TKBFLT325R	<b>5 SERIES</b>	<b>2 / 2.5 TON</b>	<b>2J ENGINE</b>	<b>DIESEL</b>	
	<a href="#"><b>5 SERIES</b></a>				
74H-333-5-4-5	<b>5 SERIES</b>	<b>4.5 / 4 TON</b>	<b>3F / 1FZ ENGINE</b>	<b>PETROL - GAS</b>	
74H-333-5-4-5S	<b>5 SERIES</b>	<b>4.5 / 4 TON</b>	<b>SPLINE BEARING MODIFICATION</b>		
	<a href="#"><b>5 SERIES</b></a>				
74H-333-5-4-5	<b>5 SERIES</b>	<b>4.5 / 4 TON</b>	<b>11Z ENGINE</b>	<b>DIESEL</b>	
74H-333-5-4-5S	<b>5 SERIES</b>	<b>4.5 / 4 TON</b>	<b>SPLINE BEARING MODIFICATION</b>		
	<a href="#"><b>5 SERIES</b></a>				
74H-332-5-E-1-5	<b>5 SERIES</b>	<b>1 / 1.3 / 1.5 / 3 TON</b>	<b>MOTOR</b>	<b>ELECTRIC</b>	
	<a href="#"><b>3 / 4 / 5 SERIES 1.8 / 2 / 2.5 / 3 / 5 TON</b></a>		<a href="#"><b>3 / 4 / 5 SERIES 4 TON</b></a>		
					

**PLEASE NOTE: ALL O.E.M. NAMES OR NUMBERS ARE FOR REFERENCE USE ONLY**

<u>Part Number</u>	<b>FORKLIFT PUMPS</b>			<u>RETAIL:</u>
				<b>01-10-2022</b>
	<u><a href="#">TOYOTA</a></u>			
	<u><a href="#">6 SERIES</a></u>			
74H-TKBFLT625R	6 SERIES 1.8 / 2 / 2.5 / 3 TON	4Y ENGINE	PETROL - GAS	
	<u><a href="#">6 SERIES</a></u>			
74H-TKBFLT625R	6 SERIES 1.8 / 2 / 2.5 / 3 TON	1DZ 2 ENGINE	DIESEL	
	<u><a href="#">6 SERIES</a></u>			
74H-332-6-2Z	6 SERIES 2 / 2.5 / 3 TON	2Z ENGINE	DIESEL	
	<u><a href="#">6 SERIES</a></u>			
74H-333-6-4-5	6 SERIES 4.5 / 4 TON	3F / 1FZ ENGINE	PETROL - GAS	
74H-333-6-4-5S	6 SERIES 4.5 / 4 TON	SPLINE BEARING MODIFICATION		
	<u><a href="#">6 SERIES</a></u>			
74H-333-6-4-5	6 SERIES 4.5 / 4 TON	11Z ENGINE	DIESEL	
74H-333-6-4-5S	6 SERIES 4.5 / 4 TON	SPLINE BEARING MODIFICATION		
	<u><a href="#">6 SERIES</a></u>			
74H-332-6-E-1-5	6 FBRE SERIES 1 / 1.3 / 1.5 / 3 TON	MOTOR	ELECTRIC	
	<u><a href="#">7 SERIES</a></u>			
74H-TKBFLT725R	7 SERIES 1.8 / 2 / 2.5 / 3 TON	4Y ENGINE	PETROL - GAS	
	<u><a href="#">7 SERIES</a></u>			
74H-TKBFLT725R	7 SERIES 1.8 / 2 / 2.5 / 3 TON	1DZ 2 ENGINE	DIESEL	
	<u><a href="#">7 SERIES</a></u>			
74H-332-7-2Z	7 SERIES 2 / 2.5 / 3 TON	2Z ENGINE	DIESEL	
	<u><a href="#">7 SERIES</a></u>			
74H-333-7-4-5	7 SERIES 4.5 / 4 TON	GM ENGINE	PETROL - GAS	
74H-333-7-4-5S	7 SERIES 4.5 / 4 TON	SPLINE BEARING MODIFICATION		
	<u><a href="#">7 SERIES</a></u>			
74H-333-7-4-5	7 SERIES 4.5 / 4 TON	13Z ENGINE	DIESEL	
74H-333-7-4-5S	7 SERIES 4.5 / 4 TON	SPLINE BEARING MODIFICATION		
	<u><a href="#">7 SERIES</a></u>			
74H-332-7-E-1-5	7 FBRE SERIES 1 / 1.3 / 1.5 / 3 TON	MOTOR	ELECTRIC	
	<u><a href="#">6 SERIES 1.8 / 2 / 2.5 / 3 TON</a></u>	<u><a href="#">7 SERIES 1.8 / 2 / 2.5 / 3 TON</a></u>		
				

PLEASE NOTE: ALL O.E.M. NAMES OR NUMBERS ARE FOR REFERENCE USE ONLY

Part Number	FORKLIFT PUMPS			RETAIL:
	<b>TOYOTA</b>			01-10-2022
	<u>8 SERIES</u>			
74H-TKBFLT827R	8 SERIES 1.8 / 2 / 2.5 / 3 TON	4Y ENGINE	PETROL	
	<u>8 SERIES</u>			
74H-TKBFLT827R	8 SERIES 1.8 / 2 / 2.5 / 3 TON	1DZ2 ENGINE	DIESEL	
	<u>8 SERIES</u>			
74H-333-8-4-5	8 SERIES	4.5 / 4 TON	GM ENGINE PETROL - GAS	
74H-333-8-4-5S	8 SERIES	4.5 / 4 TON	SPLINE BEARING MODIFICATION	
	<u>8 SERIES</u>			
74H-333-8-4-5	8 SERIES	4.5 / 4 TON	GM ENGINE DIESEL	
74H-333-8-4-5S	8 SERIES	4.5 / 4 TON	SPLINE BEARING MODIFICATION	
	<u>8 SERIES 1.8 / 2 / 2.5 / 3 TON</u>			
				
	<u>8 SERIES 1.8 / 2 / 2.5 / 3 TON</u>			
				
PLEASE NOTE: ALL O.E.M. NAMES OR NUMBERS ARE FOR REFERENCE USE ONLY				PAGE 03

<u>Part Number</u>	<b>FORKLIFT PUMPS</b>			RETAIL:
				01-10-2022
	<u>TCM</u>			
	<u>NF SERIES</u>			
74H-TKBFLTC25L	TCM NF SERIES 2.5 TON			
	<u>NF SERIES</u>			
74H-TKBFLTC25L	NF SERIES 2.5 TON	DIESEL C240 OR Z2	CCW / C/U	
	<u>NF SERIES</u>			
74H-334KYB85A	NF SERIES 2.5 TON	DIESEL OR PETROL NISSAN H20	CCW / C/U	
	<u>FHD SERIES</u>			
74H-332TCC240	FHD SERIES 2.5 TON	DIESEL C 240 / Z2	CCW / CU	
	<u>FHG SERIES</u>			
74H-332FLTC2-5	FHG SERIES 2.5 TON	PETROL H 20 / Z 24	CW / CU	
	<u>FRSB SERIES</u>			
74H-332FLTCE	FRSB SERIES 2 TON 1150 15H2	ELECTRIC	CCW / C/U	
	<u>FRSB SERIES</u>			
74H-332TC-E	FRSB SERIES 2.5 TON 25 A 4 18 A 4	ELECTRIC	CC/W/C/U	
	<u>FD SERIES</u>			
74H-326XXXXXX	FD 70 Z 7 SERIES 7 TON	P315 SPECIAL 80mm spigot diesel	CW&CCW	

**NF SERIES**



**P511 KYB 85 A**





**FHD / FHG SERIES**





Part Number	FORKLIFT PUMPS		RETAIL:
			01-10-2022
	<u>HYSTER</u>		
	<u>XL SERIES 2.5 TON</u>	PETROL	C/W
74H-3349112288	P11A193PAX10XX23XX	XXXCHANGE ROTATION	
	<u>XL SERIES 2.5 TON</u>	DIESEL	CC/W
74H-3349112288	P11A293PAX10XX23XX		
	<u>XL SERIES 4 / 5 TON F5 / G5</u>	DIESEL	CC/W
74H-3249110127	P330A297XXAB17-25		
	<u>XL SERIES H16 TON 5 HIGH</u>	DIESEL	C/W
74H-3229529072	P365B178XXAB13-7/P330AXXAB10-XXPRV1V		
	<u>XL SERIES 2 - 2.5 TON E2 / E3</u>	ELECTRIC	C/W
74H-332-HY-E	P11A193BEXX19-97	XXPORTS S/F M10X1.5 / SHAFT 5/8" P/KEY	
	<u>XM SERIES 2.5 TON</u>	DIESEL	CC/W
74H-332HYXMD	P11 A293X PA / 10 XX 27 - 92	XXSEC CUT OUT / 11 TOOTH	
	<u>XM SERIES 2.5 TON</u>	PETROL / GAS	C/W
74H-332HYXMP	P11 A193X PA / 10 XX 27 - 92	XXSEC CUT OUT / 11 TOOTH	
	<u>H40H / H60H SERIES</u>	DIESEL	CC/W
74H-3339110222	P17A193PE/10AJ38-65		
	<u>H40H / H60H SERIES</u>	PETROL	C/W
74H-3339110222	P17A193PE/10AJ38-65		
	<u>H40H / H60H SERIES</u>	GM ENGINE PETROL	CC/W
74H-3339110222	P17A293PE/10AJ38-65		
	** DENOTES : 1 HOUR ASSEMBLY XXX DENOTES 2 HOUR OR 24 HOUR ASSEMBLY		
	<u>XL / XM SERIES</u>		
			
		<u>H40 / H60H SERIES</u>	
			
	PLEASE NOTE: ALL O.E.M. NAMES OR NUMBERS ARE FOR REFERENCE USE ONLY		PAGE 05



<u>Part Number</u>	<b>FORKLIFT PUMPS</b>			RETAIL:
				01-10-2022
	<b><u>CLARK</u></b>			
74H-332-FL-CL	DPN 25 / 30 SERIES	2 - 3 TON	DIESEL	CW
	P11 A193 PA / 10 xx 23 - 96		XXPORTS BOSCH TYPE SQUARE / 9 TOOTH	
	<b><u>NISSAN</u></b>			
74H-3349112288	SERIES EH02U	2.5 TON	DIESEL	CW
	P11 A193PAX10XX23XX		XXPEC CUT OUT / ENGINE SD25	
	<b><u>MITSUBISHI</u></b>			
74H-332-MIT-15	FD 15 SERIES	1.5 TON		CC/W
	P11 A293PC09FD33XX		XXSHAFT 10 TOOTH 17.7mm OD SPECIAL	
	SUCTION PORT 3/4" S/F M8			
	<b><u>MITSUBISHI</u></b>			
74H-332-MIT-25	FD 25 SERIES	2.5 TON		CC/W
	P11 A293PC09FD33XX		XXSHAFT 10 TOOTH 17.7mm OD SPECIAL	
	SUCTION PORT 1" S/F M10X1 <b>WARNING 82mm SPIGOT PART NUMBER 7733204086051</b>			
	<b><u>KALMAR</u></b>			
	SERIES EC7	25 TON	DIESEL	CW
74H-3229111239	P365 A178ETAB17-7		MAIN	
	<b><u>KALMAR</u></b>			
	SERIES DCD 280	28 TON	PETROL	CCW
74H-3249110239	P330 A197XXAB20-25		STEER	
	<b><u>KALMAR</u></b>			
	SERIES DCD 280	28 TON	DIESEL	CW
74H-3229111239	P365 A178ETAB17-7		MAIN	
	<b><u>KALMAR</u></b>			
	SERIES DCD 280	28 TON	DIESEL	CW
74H-3249110239	P330 A197XXAB20-25		STEER	
	<b><u>Mitsubishi Forklift</u></b>			
				
			<b>Kalmar Forklift</b>	
				
	<b>PLEASE NOTE: ALL O.E.M. NAMES OR NUMBERS ARE FOR REFERENCE USE ONLY</b>			<b>PAGE 06</b>

Part Number	PUMPS GEAR CAST IRON					RETAIL:
						01-10-2022
<u>P20 SERIES FROM COMMERCIAL SHEARING</u>						
	CODE	GEAR WIDTH	4073	CONT / PRESS	CODE	
75H-P20-05	05	1/2"	16.34	200 Bar	05	
75H-P20-07	07	3/4"	24.21	200 Bar	07	
75H-P20-10	10	1"	32.29	200 Bar	10	
75H-P20-12	12	1-1/4"	40.36	200 Bar	12	
75H-P20-15	15	1 -1/2"	48.43	200 Bar	15	
75H-P20-17	17	1 -3/4"	56.50	170 Bar	17	
75H-P20-20	20	2"	64.58	170 Bar	20	
<u>ADD ON PRICE FOR MULTIPLE STAGE PUMPS PER SECTION</u>						
	CODE	GEAR WIDTH	CC / REV	CONT / PRESS	CODE	
75H-P20-05-XX	05	1/2"	16.34	200 Bar	05	
75H-P20-07-XX	07	3/4"	24.21	200 Bar	07	
75H-P20-10-XX	10	1"	32.29	200 Bar	10	
75H-P20-12-XX	12	1-1/4"	40.36	200 Bar	12	
75H-P20-15-XX	15	1 -1/2"	48.43	200 Bar	15	
75H-P20-17-XX	17	1 -3/4"	56.50	170 Bar	17	
75H-P20-20-XX	20	2"	64.58	170 Bar	20	
<u>ADD ON PRICES</u>						
75H-P20-M	MOTOR					
75H-P20-PTL	TELL TAIL DRAIN (DOUBLE SHAFT SEAL)					
	SHAFTS	SPIGOTS	PORTS	ROTATION	SPEED	
	*3/4" P/KEY	2-5/8" 6 BOLT	BSPP	C / W	600 MIN rpm	
	7/8" P/KEY	3-1/4" 2 BOLT	NPT	CC / W	2400 MAX rpm	
	1" P/KEY	4" 2 BOLT	SAE "O"	B I		
	*1-1/4" P/KEY	4" 4 BOLT	S/F 4 BOLT			
	9 TOOTH					
	13 TOOTH					
	*14 TOOTH					
* DENOTES : CONTI SHAFT, USE ONLY AFTER CONSULTING SIDE LOAD SPECS						
						
PLEASE NOTE: ALL O.E.M. NAMES OR NUMBERS ARE FOR REFERENCE USE ONLY						
						PAGE P 1

Part Number	PUMPS GEAR CAST IRON					RETAIL:
						01-10-2022
<u>P30 SERIES FROM COMMERCIAL SHEARING</u>						
	CODE	GEAR WIDTH	CC / REV	CONT / PRESS	CODE	
75H-P30-05	05	1/2"	16.34	170 Bar	05	
75H-P30-07	07	3/4"	24.21	170 Bar	07	
75H-P30-10	10	1"	32.29	170 Bar	10	
75H-P30-12	12	1-1/4"	40.36	170 Bar	12	
75H-P30-15	15	1 -1/2"	48.43	170 Bar	15	
75H-P30-17	17	1 -3/4"	56.50	150 Bar	17	
75H-P30-20	20	2"	64.58	150 Bar	20	
75H-P30-25	25	2- 1/2"	80.00	150 Bar	25	
<u>ADD ON PRICE FOR MULTIPLE STAGE PUMPS PER SECTION</u>						
	CODE	GEAR WIDTH	CC / REV	CONT / PRESS	CODE	
75H-P30-05-XX	05	1/2"	16.34	170 Bar	05	
75H-P30-07-XX	07	3/4"	24.21	170 Bar	07	
75H-P30-10-XX	10	1"	32.29	170 Bar	10	
75H-P30-12-XX	12	1-1/4"	40.36	170 Bar	12	
75H-P30-15-XX	15	1 -1/2"	48.43	170 Bar	15	
75H-P30-17-XX	17	1 -3/4"	56.50	150 Bar	17	
75H-P30-20-XX	20	2"	64.58	150 Bar	20	
75H-P30-25-XX	25	2- 1/2"	80.00	150 Bar	25	
<u>ADD ON PRICES</u>						
75H-P30-M	MOTOR					
75H-P30-D	DOWELS INCLUDED IN PRICE					
75H-P30-TT	TELL TAIL DRAIN (DOUBLE SHAFT SEAL)					
75H-P30-PB	PIGGY BACK P30 - P30					
75H-P30-PR	PRIORITY FLOW DIVIDER					
	SHAFTS	SPIGOTS	PORTS	ROTATION	SPEED	
	*3/4" P/KEY	2-5/8" 6 BOLT	BSPP	C / W	600 MIN rpm	
	7/8" P/KEY	3-1/4" 2 BOLT	NPT	CC / W	2400 MAX rpm	
	1" P/KEY	4" 2 BOLT	SAE "O"	B I		
	*1-1/4" P/KEY	4" 4 BOLT	S/F 4 BOLT			
	9 TOOTH	5" 4 BOLT				
	13 TOOTH					
	*14 TOOTH					
* DENOTES : CONTI SHAFT, USE ONLY AFTER CONSULTING SIDE LOAD SPECS						
						
PLEASE NOTE: ALL O.E.M. NAMES OR NUMBERS ARE FOR REFERENCE USE ONLY						PAGE P 2

Part Number	PUMPS GEAR CAST IRON					RETAIL:
						01-10-2022
<u>P25X SERIES FROM COMMERCIAL SHEARING</u>						
	CODE	GEAR WIDTH	CC / REV	CONT / PRESS	CODE	
75H-P25X-05	05	1/2"	20.89	140 Bar	05	
75H-P25X-07	07	3/4"	31.34	140 Bar	07	
75H-P25X-10	10	1"	41.79	140 Bar	10	
75H-P25X-12	12	1-1/4"	50.54	140 Bar	12	
75H-P25X-15	15	1-1/2"	62.68	140 Bar	15	
75H-P25X-17	17	1-3/4"	73.13	140 Bar	17	
75H-P25X-20	20	2"	83.58	140 Bar	20	
75H-P25X-22	22	2-1/4"	94.00	140 Bar	22	
75H-P25X-25	25	2-1/2"	104.47	140 Bar	25	
<u>ADD ON PRICE FOR MULTIPLE STAGE PUMPS PER SECTION</u>						
	CODE	GEAR WIDTH	CC / REV	CONT / PRESS	CODE	
75H-P25X-05-XX	05	1/2"	20.89	140 Bar	05	
75H-P25X-07-XX	17	3/4"	31.34	140 Bar	07	
75H-P25X-10-XX	10	1"	41.79	140 Bar	10	
75H-P25X-12-XX	12	1-1/4"	50.54	140 Bar	12	
75H-P25X-15-XX	15	1-1/2"	62.68	140 Bar	15	
75H-P25X-17-XX	17	1-3/4"	73.13	140 Bar	17	
75H-P25X-20-XX	20	2"	83.58	140 Bar	20	
75H-P25X-22-XX	22	2-1/4"	94.00	140 Bar	22	
75H-P25X-25-XX	25	2-1/5"	104.47	140 Bar	25	
<u>ADD ON PRICES</u>						
75H-P25X-M	MOTOR					
75H-P25X-LN	LONG NECK S. E. C.					
	SHAFTS	SPIGOTS	PORTS	ROTATION	SPEED	
	*7/8" P/KEY	2-5/8" 6 BOLT	BSP	C / W	600 MIN rpm	
	*1" P/KEY	4" 2 BOLT	NPT	CC / W	2400 MAX rpm	
	*1-1/4" P/KEY	4" 4 BOLT	SAE "O"	B I		
	*13 TOOTH	5" 2 BOLT	S/F 4 BOLT			
	*14 TOOTH	5" 4 BOLT				
* DENOTES : CONTI SHAFT, USE ONLY AFTER CONSULTING SIDE LOAD SPECS						
						
PLEASE NOTE: ALL O.E.M. NAMES OR NUMBERS ARE FOR REFERENCE USE ONLY						

Part Number	<b>PUMPS GEAR CAST IRON</b>					RETAIL:
						01-10-2022
<b><u>P50 SERIES FROM COMMERCIAL SHEARING</u></b>						
	CODE	GEAR WIDTH	CC / REV	CONT / PRESS	CODE	
75H-P50-05	05	1/2"	20.89	170 Bar	05	
75H-P50-07	07	3/4"	31.34	170 Bar	07	
75H-P50-10	10	1"	41.79	170 Bar	10	
75H-P50-12	12	1-1/4"	50.54	170 Bar	12	
75H-P50-15	15	1 -1/2"	62.68	170 Bar	15	
75H-P50-17	17	1 -3/4"	73.13	140 Bar	17	
75H-P50-20	20	2"	83.58	140 Bar	20	
75H-P50-22	22	2 -1/4"	94.00	140 Bar	22	
75H-P50-25	25	2- 1/2"	104.47	140 Bar	25	
<b><u>ADD ON PRICE FOR MULTIPLE STAGE PUMPS PER SECTION</u></b>						
	CODE	GEAR WIDTH	CC / REV	CONT / PRESS	CODE	
75H-P50-05-XX	05	1/2"	20.89	170 Bar	05	
75H-P50-07-XX	07	3/4"	31.34	170 Bar	07	
75H-P50-10-XX	10	1"	41.79	170 Bar	10	
75H-P50-12-XX	12	1-1/4"	50.54	170 Bar	12	
75H-P50-15-XX	15	1 -1/2"	62.68	170 Bar	15	
75H-P50-17-XX	17	1 -3/4"	73.13	140 Bar	17	
75H-P50-20-XX	20	2"	83.58	140 Bar	20	
75H-P50-22-XX	22	2- 1/4"	94.00	140 Bar	22	
75H-P50-25-XX	25	2- 1/2"	104.47	140 Bar	25	
<b><u>ADD ON PRICES</u></b>						
75H-P50-M	MOTOR					
75H-P50-D	DOWELS INCLUDED IN PRICE					
75H-P50-TL	TELL TAIL DRAIN (DOUBLE SHAFT SEAL)					
75H-P50-PB	PIGGY BACK P50 - P30					
75H-P50-PR	PRIORITY FLOW DIVIDER					
	SHAFTS	SPIGOTS	PORTS	ROTATION	SPEED	
	1" P/KEY	PAD MOUNT	BSPF	C / W	600 MIN rpm	
	1-1/4" P/KEY	4" 2 BOLT	NPT	CC / W	2400 MAX rpm	
	13 TOOTH	4" 4 BOLT	SAE "O"	BI		
	14 TOOTH	5" 2 BOLT	S/F 4 BOLT			
	*15 TOOTH	5" 4 BOLT				
						
<b>PLEASE NOTE: ALL O.E.M. NAMES OR NUMBERS ARE FOR REFERENCE USE ONLY</b>						

<u>Part Number</u>	<b>PUMPS GEAR CAST IRON</b>					<b>RETAIL:</b>
						<b>01-10-2022</b>
<b><u>P75 SERIES FROM COMMERCIAL SHEARING</u></b>						
	<b>CODE</b>	<b>GEAR WIDTH</b>	<b>CC / REV</b>	<b>CONT / PRESS</b>	<b>CODE</b>	
75H-P75-10	10	1"	67.00	170 Bar	10	
75H-P75-12	12	1-1/4"	84.00	170 Bar	12	
75H-P75-15	15	1 -1/2"	100.80	170 Bar	15	
75H-P75-17	17	1 -3/4"	117.60	170 Bar	12	
75H-P75-20	20	2"	134.40	150 Bar	20	
75H-P75-22	22	2 -1/4"	151.20	150 Bar	22	
75H-P75-25	25	2- 1/2"	168.00	150 Bar	25	
75H-P75-27	27	2 -3/4"	184.80	150 Bar	27	
75H-P75-30	30	3"	210.60	150 Bar	30	
<b><u>ADD ON PRICE FOR MULTIPLE STAGE PUMPS PER SECTION</u></b>						
	<b>CODE</b>	<b>GEAR WIDTH</b>	<b>CC / REV</b>	<b>CONT / PRESS</b>	<b>CODE</b>	
75H-P75-07-XX	07	3/4"	50.00	170 Bar	07	
75H-P75-10-XX	10	1"	67.00	170 Bar	10	
75H-P75-12-XX	12	1-1/4"	84.00	170 Bar	12	
75H-P75-15-XX	15	1 -1/2"	100.80	170 Bar	15	
75H-P75-17-XX	17	1 -3/4"	117.60	170 Bar	17	
75H-P75-20-XX	20	2"	134.40	150 Bar	20	
75H-P75-22-XX	22	2 -1/4"	151.20	150 Bar	22	
75H-P75-25-XX	25	2- 1/2"	168.00	150 Bar	25	
75H-P75-27-XX	27	2 -3/4"	184.80	150 Bar	27	
75H-P75-30-XX	30	3"	210.60	150 Bar	30	
<b><u>ADD ON PRICES</u></b>						
75H-M	MOTOR					
75H-D	DOWELS INCLUDED IN PRICE					
75H-TL	TELL TAIL DRAIN (DOUBLE SHAFT SEAL)					
75H-PB	PIGGY BACK P75 - 50 - 30					
	<b>SHAFTS</b>	<b>SPIGOTS</b>	<b>PORTS</b>	<b>ROTATION</b>	<b>SPEED</b>	
	1-1/4" P/KEY	4" 4 BOLT	BSPP	C / W	600 MIN rpm	
	14 TOOTH	5" 2 BOLT	NPT	CC / W	2400 MAX rpm	
		5" 4 BOLT	SAE "O"	B I		
		6" 4 BOLT	S/F 4 BOLT			
						
<b>PLEASE NOTE: ALL O.E.M. NAMES OR NUMBERS ARE FOR REFERENCE USE ONLY</b>						



<u>Part Number</u>	<b>PUMPS GEAR CAST IRON</b>					RETAIL:
						01-10-2022
<u>P315 SERIES FROM COMMERCIAL SHEARING</u>						
	CODE	GEAR WIDTH	CC / REV	CONT / PRESS	CODE	
75H-P315-05	05	1/2"	10.33	245 Bar	05	
75H-P315-07	07	3/4"	15.41	245 Bar	07	
75H-P315-10	10	1"	20.49	245 Bar	10	
75H-P315-12	12	1-1/4"	25.57	245 Bar	12	
75H-P315-15	15	1 -1/2"	30.81	225 Bar	15	
75H-P315-17	17	1 -3/4"	35.89	200 Bar	17	
75H-P315-20	20	2"	40.58	175 Bar	20	
<u>ADD ON PRICE FOR MULTIPLE STAGE PUMPS PER SECTION</u>						
	CODE	GEAR WIDTH	CC / REV	CONT / PRESS	CODE	
75H-P315-05-XX	05	1/2"	10.33	245 Bar	05	
75H-P315-07-XX	07	3/4"	15.41	245 Bar	07	
75H-P315-10-XX	10	1"	20.49	245 Bar	10	
75H-P315-12-XX	12	1-1/4"	25.57	245 Bar	12	
75H-P315-15-XX	15	1 -1/2"	30.81	225 Bar	15	
75H-P315-17-XX	17	1 -3/4"	35.89	200 Bar	17	
75H-P315-20-XX	20	2"	40.58	175 Bar	20	
<u>ADD ON PRICES</u>						
75H-P315-M	MOTOR					
75H-P315-PEC	P.E.C. 1 -1/2- SPLIT FLANGE PORTS					
75H-P315-BRG	BRG/CARR 1- 1/2 SPLIT FLANGE PORTS					
75H-P315-PR	PRIORITY FLOW DIVIDER					
	SHAFTS	SPIGOTS	PORTS	ROTATION	SPEED	
	7/8" P/KEY	3-1/4" 2 BOLT	BSPP	C / W	600 MIN rpm	
	13 TOOTH	4" 2 BOLT	NPT	CC / W	2400 MAX rpm	
			SAE "O"			
			S/F 4 BOLT			
						
<b>PLEASE NOTE: ALL O.E.M. NAMES OR NUMBERS ARE FOR REFERENCE USE ONLY</b>						

Part Number	PUMPS GEAR CAST IRON					RETAIL:
						01-10-2022
<u>P330 SERIES FROM COMMERCIAL SHEARING</u>						
	CODE	GEAR WIDTH	CC / REV	CONT / PRESS	CODE	
75H-P330-05	05	1/2"	16.24	245 Bar	05	
75H-P330-07	07	3/4"	24.21	245 Bar	07	
75H-P330-10	10	1"	32.29	245 Bar	10	
75H-P330-12	12	1-1/4"	40.36	245 Bar	12	
75H-P330-15	15	1 -1/2"	48.43	245 Bar	15	
75H-P330-17	17	1 -3/4"	56.5	225 Bar	17	
75H-P330-20	20	2"	64.58	210 Bar	20	
<u>ADD ON PRICE FOR MULTIPLE STAGE PUMPS PER SECTION</u>						
	CODE	GEAR WIDTH	CC / REV	CONT / PRESS	CODE	
75H-P330-05-XX	05	1/2"	16.24	245 Bar	05	
75H-P330-07-XX	07	3/4"	24.21	245 Bar	07	
75H-P330-10-XX	10	1"	32.29	245 Bar	10	
75H-P330-12-XX	12	1-1/4"	40.36	245 Bar	12	
75H-P330-15-XX	15	1 -1/2"	48.43	245 Bar	15	
75H-P330-17-XX	17	1 -3/4"	56.5	225 Bar	17	
75H-P330-20-XX	20	2"	64.58	210 Bar	20	
<u>ADD ON PRICES</u>						
75H-P330-M	MOTOR					
75H-P330-TL	TELL TAIL DRAIN (DOUBLE SHAFT SEAL)					
75H-P330-P315	MULTIPLE UNITS STEP SIZE P330/P315					
75H-P330-P11	MULTIPLE UNITS STEP SIZE P330/P11					
75H-P330-PF	PRIORITY FLOW DIVIDER					
75H-P330-UNLV	UNLOADING VALVE P330/315 BRG/CARR					
	SHAFTS	SPIGOTS	PORTS	ROTATION	SPEED	
	7/8" P/KEY	4" 2 BOLT	BSP	C / W	600 MIN rpm	
	1" P/KEY	4" 4 BOLT	NPT	CC / W	2400 MAX rpm	
	*1-1/4" P/KEY	5" 2 BOLT	SAE "O"	B I		
	13 TOOTH	5" 4 BOLT	S/F 4 BOLT			
	*14 TOOTH					
	15 TOOTH					
* DENOTES : CONTI SHAFT, USE ONLY AFTER CONSULTING SIDE LOAD SPECS						
						
<b>PLEASE NOTE: ALL O.E.M. NAMES OR NUMBERS ARE FOR REFERENCE USE ONLY</b>						<b>PAGE P 7</b>

Part Number	PUMPS GEAR CAST IRON					RETAIL:
						01-10-2022
<u>P350 SERIES FROM COMMERCIAL SHEARING</u>						
	CODE	GEAR WIDTH	CC / REV	CONT / PRESS	CODE	
75H-P350-05	05	1/2"	20.89	245 Bar	05	
75H-P350-07	07	3/4"	31.34	245 Bar	07	
75H-P350-10	10	1"	41.79	245 Bar	10	
75H-P350-12	12	1-1/4"	50.54	245 Bar	12	
75H-P350-15	15	1 -1/2"	62.68	245 Bar	15	
75H-P350-17	17	1 -3/4"	73.13	225 Bar	17	
75H-P350-20	20	2"	83.58	210 Bar	20	
75H-P350-22	22	2 -1/4"	94.00	190 Bar	22	
75H-P350-25	25	2- 1/2"	104.47	170 Bar	25	
<u>ADD ON PRICE FOR MULTIPLE STAGE PUMPS PER SECTION</u>						
	CODE	GEAR WIDTH	CC / REV	CONT / PRESS	CODE	
75H-P350-05-XX	05	1/2"	20.89	245 Bar	05	
75H-P350-07-XX	07	3/4"	31.34	245 Bar	07	
75H-P350-10-XX	10	1"	41.79	245 Bar	10	
75H-P350-12-XX	12	1-1/4"	50.54	245 Bar	12	
75H-P350-15-XX	15	1 -1/2"	62.68	245 Bar	15	
75H-P350-17-XX	17	1 -3/4"	73.13	225 Bar	17	
75H-P350-20-XX	20	2"	83.58	210 Bar	20	
75H-P350-22-XX	22	2 -1/4"	94.00	190 Bar	22	
75H-P350-25-XX	25	2- 1/2"	104.47	170 Bar	25	
<u>ADD ON PRICES</u>						
75H-P350-M	MOTOR					
75H-P350-ZF	ZF TYPE 4 BOLT P.T.O. S.E.C. & SHAFT					
75H-P350-TL	TELL TAIL DRAIN (DOUBLE SHAFT SEAL)					
75H-P350-P315	MULTIPLE UNITS STEP SIZE COMMON OIL COMMON SUCTION P350/P315					
75H-P350-P11	MULTIPLE UNITS STEP SIZE COMMON OIL COMMON SUCTION P350/P11					
75H-P350-13SP	MULTIPLE UNITS STEP SIZE SEALED OILS TO S.A.E. B 4" 2 BOLT; B SPLINE 13 TOOTH					
	SHAFTS	SPIGOTS	PORTS	ROTATION	SPEED	
	1" P/KEY	4" 2 BOLT	BSPP	C / W	600 MIN rpm	
	1-1/4" P/KEY	4" 4 BOLT	NPT	CC / W	2400 MAX rpm	
	13 TOOTH	5" 2 BOLT	SAE "O"	B I		
	14 TOOTH	5" 4 BOLT	S/F 4 BOLT			
	* DENOTES : CONTI SHAFT, USE ONLY AFTER CONSULTING SIDE LOAD SPECS					



Part Number	<b>PUMPS GEAR CAST IRON</b>					RETAIL:
						01-10-2022
	<b><u>P365 SERIES FROM COMMERCIAL SHEARING</u></b>					
	CODE	GEAR WIDTH	CC / REV	CONT / PRESS	CODE	
75H-P365-10	10	1"	59.00	240 Bar	10	
75H-P365-12	12	1-1/4"	73.75	240 Bar	12	
75H-P365-15	15	1 -1/2"	88.50	240 Bar	15	
75H-P365-17	17	1 -3/4"	103.25	240 Bar	17	
75H-P365-20	20	2"	118.00	240 Bar	20	
75H-P365-22	22	2 -1/4"	132.75	242 Bar	22	
75H-P365-25	25	2- 1/2"	147.50	200 Bar	25	
	<b><u>ADD ON PRICE FOR MULTIPLE STAGE PUMPS PER SECTION</u></b>					
	CODE	GEAR WIDTH	CC / REV	CONT / PRESS	CODE	
75H-P365-07-XX	07	3/4"	44.25	240 Bar	07	
75H-P365-10-XX	10	1"	59.00	240 Bar	10	
75H-P365-12-XX	12	1-1/4"	73.75	240 Bar	12	
75H-P365-15-XX	15	1 -1/2"	88.50	240 Bar	15	
75H-P365-17-XX	17	1 -3/4"	103.25	240 Bar	17	
75H-P365-20-XX	20	2"	118.00	240 Bar	20	
75H-P365-22-XX	22	2 -1/4"	132.75	242 Bar	22	
75H-P365-25-XX	25	2- 1/2"	147.50	200 Bar	25	
	<b><u>ADD ON PRICES</u></b>					
75H-P365-M	MOTOR					
75H-P365-TL	TELL TAIL DRAIN (DOUBLE SHAFT SEAL)					
75H-P365-P330	MULTIPLE UNITS STEP SIZE COMMON OIL COMMON SUCTION P365/P330					
75H-P365-SAE4	MULTIPLE UNITS STEP SIZE SEALED OILS TO S.A.E. B 4" 2 BOLT FLANGE					
75H-P365-ADSP	MULTIPLE UNITS STEP SIZE SEALED OILS ADAPTOR SPLINES S.A.E. A & B					
	SHAFTS	SPIGOTS	PORTS	ROTATION	SPEED	
	1-1/4" P/KEY	4" 2 BOLT	BSPP	C / W	600 MIN rpm	
	14 TOOTH	4" 4 BOLT	NPT	CC / W	2400 MAX rpm	
		5" 2 BOLT	SAE "O"	B I		
		5" 4 BOLT	S/F 4 BOLT			



<u>Part Number</u>	<b>PISTON &amp; TWIN SHAFT GEAR PUMPS P.T.O.</b>							<b>RETAIL:</b>
								<b>01-10-2022</b>
	<u>D.I.N. TYPE</u>							
	<u>GPM MK11 D.I.N. SINGLE FLOW TRUCK PUMPS</u>							
	<u>MOUNTINGS</u> : ( D ) DIN 4 BOLT							
	<u>SHAFTS</u> : ( D ) DIN 8 SPLINE							
	<u>ROTATION</u> : ( BI ) ROTATION							
	<u>TECHNICAL DATA D.I.N. PISTON SINGLE STAGE</u>							
	<u>DESCRIPTION</u>	<u>PORTS</u>	<u>P0RTS</u>	<u>PRESSURE</u>	<u>MAX SPEED</u>	<u>WEIGHT</u>	<u>FLOW</u>	
		<u>INLET</u>	<u>OUTLET x 1</u>	<u>Bar</u>	<u>RPM</u>	<u>Kg</u>	<u>cc/rev</u>	
76H-50-MK11	MK11 - 50 - R	1-1/4" BSP	3/4" BSP	300	1400	10	50	
76H-60-MK11	MK11 - 60 - R	1-1/4" BSP	3/4" BSP	300	1400	10	60	
76H-80-MK11	MK11 - 80 - R	1-1/2" BSP	3/4" BSP	300	1400	12	80	

**D.I.N. 8 SPLINE**



**TWIN SHAFT PUMP C151 (NO CONTROL VALVE)**

76H-GP113-22	C 151	100cc per rev	1 1/8" SHAFT	1-1/2" NPT x 3/4" SAE O'RING PORTS
76H-3159310018				

**TWIN SHAFT PUMP C101 (WITH CONTROL AND RELIEF VALVE)**

76H-GP110-20	C 101	80cc per rev	1" SHAFT	1-1/4" x 3/4" NPT PORTS
76H-3149310215				

**P.T.O. PUMPS ACCESSORIES**

76H-3912883106	C 101 SHAFT SEALS ( SET OF 2 AND 2 BODY GASKETS )
76H-3912883129	G 101 SHAFT SEALS ( SET OF 2 AND 2 BODY GASKETS )
76H-3912883106	C 151 SHAFT SEALS ( SET OF 2 AND 2 BODY GASKETS )
76H-WGP-110-MB	C 101 PUMP MOUNTING BRACKET



<u>Part Number</u>	<b>GEAR PUMPS CAST IRON P.T.O.</b>	<b>RETAIL:</b>
--------------------	------------------------------------	----------------

**15-03-2023**

**TYPE : D.I.N. P.T.O.**

**G.P.M. - TRUCK PUMPS GP3 GENERATION**

**MOUNTINGS : ( D ) DIN 4 BOLT**

**SHAFTS : ( D ) DIN 8 SPLINE**

**ROTATION : ( R ) CLOCKWISE**

**( L ) ANTI CLOCKWISE**

**DESCRIPTION : GP3 ( FLOW ) ( MOUNT ) ( ROTATION )**

**EXAMPLE : GP3 - 080 - D - L**

**TECHNICAL DATA D.I.N. GEAR DOUBLE STAGE**

**SINGLE STAGE PUMP**

	FLOW	PORTS	PORTS	PRESSURE	GEAR	FRAME	FLOW
	cc/rev	INLET	OUTLET x 2	Bar	SIZE	SIZE	cc/rev
76H-GP3-024DL	024	1" BSP	3/4" BSP	300	0.75	230	024
76H-GP3-032DL	032	1" BSP	3/4" BSP	300	1.00	230	032
76H-GP3-040DL	040	1" BSP	3/4" BSP	300	1.25	230	040
76H-GP3-048DL	048	1" BSP	3/4" BSP	300	1.50	230	048
76H-GP3-052DL	052	1" BSP	1" BSP	300	1.25	250	052
76H-GP3-062DL	062	1" BSP	1" BSP	300	1.50	250	062
76H-GP3-073DL	073	1-1/4" BSP	1" BSP	270	1.25	265	073
76H-GP3-080DL	080	1-1/4" BSP	1" BSP	270	1.38	265	080
76H-GP3-088DL	088	1-1/4" BSP	1" BSP	270	1.50	265	088
76H-GP3-102DL	102	1-1/4" BSP	1" BSP	240	1.75	265	102
76H-GP3-118DL	118	1-1/4" BSP	1" BSP	240	2.00	265	118.00
76H-GP3-132DL	132	1-1/2" BSP	1" BSP	220	2.25	265	132.00
76H-GP3-147DL	147	1-1/2" BSP	1" BSP	200	2.50	265	147.00

**DOUBLE STAGE FRONT PUMP PRICE ONLY ADD ON A UNI PUMP PRICE TO MAKE UP A DOUBLE**

76H-GP3T-052	52	1"	1"	250		250	52
76H-GP3T-52-XX	52-32	1" & 1"	1" & 1"	250	250/250		52/52
76H-GP3T-062	62	1"	1"	250		250	62
76H-GP3T-062-XX	62-32	1" & 1"	1" & 3/4"	250	250/230		62/32
76H-GP3T-073	73	1-1/4"	1"	250		265	73
76H-GP3T-073-XX	73-32	1-1/4" & 1"	1" & 3/4"	250	265/230		73/32
76H-GP3T-080	80	1-1/4"	1"	250		265	80
76H-GP3T-080-XX	80-32	1-1/4" & 1"	1" & 3/4"	250	265/230		80/32
76H-GP3T-088	88	1-1/4"	1"	250		265	88
76H-GP3T-088-XX	88-32	1-1/4" & 1"	1" & 3/4"	250	265/230		88/32

**D I N 8 SPLINE**



**GP3T**

**PLEASE NOTE: ALL O.E.M. NAMES OR NUMBERS ARE FOR REFERENCE USE ONLY**

**PAGE Q2**



<u>Part Number</u>	<b>GEAR PUMPS CAST IRON P.T.O.</b>							<b>RETAIL:</b>
								<b>15-03-2023</b>
	<u>TYPE : U. N. I. P.T.O.</u>							
	<u>G.P.M. - TRUCK PUMPS GP3 GENERATION</u>							
	<u>MOUNTINGS</u> : ( U ) UNI 3 BOLT							
	<u>SHAFTS</u> : ( U ) UNI 6 SPLINE							
	<u>ROTATION</u> : ( R ) CLOCKWISE							
	( L ) ANTI CLOCKWISE							
	<u>DESCRIPTION</u> : GP3 ( FLOW ) ( MOUNT ) ( ROTATION )							
	<u>EXAMPLE</u> : GP3 - 080 - U - L							
	<u>TECHNICAL DATA D.I.N. GEAR DOUBLE STAGE</u>							
	<u>SINGLE STAGE PUMP</u>							
	<u>FLOW</u>	<u>PORTS</u>	<u>PORTS</u>	<u>PRESSURE</u>	<u>GEAR</u>	<u>FRAME</u>	<u>FLOW</u>	
	cc/rev	INLET	OUTLET x 2	Bar	SIZE	SIZE	cc/rev	
76H-GP3-024UL	024	1" BSP	3/4" BSP	300	0.75	230	024	
76H-GP3-032UL	032	1" BSP	3/4" BSP	300	1.00	230	032	
76H-GP3-040UL	040	1" BSP	3/4" BSP	300	1.25	230	040	
76H-GP3-048UL	048	1" BSP	3/4" BSP	300	1.50	230	048	
76H-GP3-052UL	052	1" BSP	1" BSP	300	1.25	250	052	
76H-GP3-062UL	062	1" BSP	1" BSP	300	1.50	250	062	
76H-GP3-073UL	073	1-1/4" BSP	1" BSP	270	1.25	265	073	
76H-GP3-080UL	080	1-1/4" BSP	1" BSP	270	1.38	265	080	
76H-GP3-088UL	088	1-1/4" BSP	1" BSP	270	1.50	265	088	
76H-GP3-102UL	102	1-1/4" BSP	1" BSP	240	1.75	265	102	
76H-GP3-118UL	118	1-1/4" BSP	1" BSP	240	2.00	265	118	
76H-GP3-132UL	132	1-1/2" BSP	1" BSP	220	2.25	265	132	
76H-GP3-147UL	147	1-1/2" BSP	1" BSP	200	2.50	265	147	

**AIR OPERATED VALVE**



**UNI 6 SPLINE**

**IN - CAB VALVE**

ACCESSORIES

76H-197KFL02000	8 - SPLINED SPICER 112 PROP SHAFT FLANGE
76H-198KPP02000	6 - SPLINED SLEEVE KIT
76H-606X01UNIZ0	3 HOLE UNI TO 4 HOLE DIN ADAPTOR & SLEEVE KIT
76H-198KPP04Q00	STUD KIT 4 STUDS & GASKET FOR THE ABOVE USE WITH ( 606X01UNIZ0 )
76H-400KCP1SS00	
76H-3VMPS000000	AIR OPERATED TIPPER CONTROL VALVE 140 Bar RELIEF SETTING
76H-M22H-C-V	IN - CAB VALVE HAND OPERATED
76H-606X14S0000	PUMP ORIENTATING ADAPTOR FLANGE U.N.I .TYPE

TYPE : SINGLE ; D.I.N. MOUNT ; 4 BOLT

HOF HIGH PRESSURE VANE PUMP

MOUNTINGS : 4 DIFFERENT POSITIONS DIN 4 BOLT

SHAFTS : DIN 5462 8 SPLINE

ROTATION : ( R ) CLOCKWISE

( L ) ANTI CLOCKWISE

PART No : HT6GC - 022 - 6 R 01-A-M1

PART No BREAKDOWN : SERIES; HT6GC DISP; 70cc SHAFT; 8 SPLINE ROTATION ; RIGHT

SINGLE VANE PUMP D.I.N.

TECHNICAL DATA

	CAM RING	DISPLACEMENT	PORTS	PORTS	PRESSURE	CAM RING	DISPLACEMENT
	SIZE	cc/rev	INLET	OUTLET	MAX INT	SIZE	cc/rev
76H-HT6GC10P	003	10.8	1-1/2" BSP	1" BSP	280 Bar	003	10.8
76H-HT6GC17P	005	17.2	1-1/2" BSP	1" BSP	280 Bar	005	17.2
76H-HT6GC21P	006	21.3	1-1/2" BSP	1" BSP	280 Bar	006	21.3
76H-HT6GC26P	008	26.4	1-1/2" BSP	1" BSP	280 Bar	008	26.4
76H-HT6GC31P	010	31.8	1-1/2" BSP	1" BSP	280 Bar	010	31.8
76H-HT6GC37P	012	37.1	1-1/2" BSP	1" BSP	280 Bar	012	37.1
76H-HT6GC46P	014	46.0	1-1/2" BSP	1" BSP	280 Bar	014	46.0
76H-HT6GC58P	017	58.3	1-1/2" BSP	1" BSP	281 Bar	017	58.3
76H-HT6GC63P	020	63.8	1-1/2" BSP	1" BSP	280 Bar	020	63.8
76H-HT6GC70P	022	70.3	1-1/2" BSP	1" BSP	280 Bar	022	70.3
76H-HT6GC79P	025	79.3	1-1/2" BSP	1" BSP	280 Bar	025	79.3
76H-HT6GC88P	028	88.8	1-1/2" BSP	1" BSP	210 Bar	028	88.8
76H-HT6GC100P	031	100.0	1-1/2" BSP	1" BSP	210 Bar	031	100.0

SPARE PARTS

76H-HT6GZC10CR	CARTRIDGE KIT 10.8cc ; CAM RING CODE 003
76H-HT6GZC17CR	CARTRIDGE KIT 17.3cc ; CAM RING CODE 005
76H-HT6GZC21CR	CARTRIDGE KIT 21.3cc ; CAM RING CODE 006
76H-HT6GZC26CR	CARTRIDGE KIT 26.4cc ; CAM RING CODE 008
76H-HT6GZC31CR	CARTRIDGE KIT 31.8cc ; CAM RING CODE 010
76H-HT6GZC37CR	CARTRIDGE KIT 37.1cc ; CAM RING CODE 012
76H-HT6GZC46CR	CARTRIDGE KIT 46.0cc ; CAM RING CODE 014
76H-HT6GZC58CR	CARTRIDGE KIT 58.3cc ; CAM RING CODE 017
76H-HT6GZC63CR	CARTRIDGE KIT 63.8cc ; CAM RING CODE 020
76H-HT6GZC70CR	CARTRIDGE KIT 70.3cc ; CAM RING CODE 022
76H-HT6GZC79CR	CARTRIDGE KIT 79.3cc ; CAM RING CODE 025
76H-HT6GZC88CR	CARTRIDGE KIT 88.8cc ; CAM RING CODE 028
76H-HT6GZC100CR	CARTRIDGE KIT 100cc ; CAM RING CODE 031

76H-HT6GCSHAF DRIVE SHAFT SINGLE

76H-HT6GCBEAR BEARING KIT SINGLE

76H-HT6GCSKIT SEAL KIT SINGLE



HT6GC

Part Number	P.T.O. VANE PUMPS CAST IRON							RETAIL:
								20-02-2023
	<b>TYPE : SINGLE ; U.N.I. MOUNT ; 3 BOLT</b>							
	<b>HOF HIGH PRESSURE VANE PUMP</b>							
	<b>MOUNTINGS : 4 DIFFERENT POSITIONS DIN 4 BOLT</b>							
	<b>SHAFTS : DIN 5463 6 SPLINE</b>							
	<b>ROTATION : ( R ) CLOCKWISE</b>							
	<b>( L ) ANTI CLOCKWISE</b>							
	<b>PART No : HT6ZC - 022 - 6 R 01-A-M1</b>							
	<b>PART No BREAKDOWN : SERIES;HT6ZC DISP;70cc SHAFT; 6 SPLINE ROTATION ; RIGHT</b>							
	<b>SINGLE VANE PUMP U.N.I..</b>							
	<b>TECHNICAL DATA</b>							
	<b>CAM RING</b>	<b>DISPLACEMENT</b>	<b>PORTS</b>	<b>PORTS</b>	<b>PRESSURE</b>	<b>CAM RING</b>	<b>DISPLACEMENT</b>	
	<b>SIZE</b>	<b>cc/rev</b>	<b>INLET</b>	<b>OUTLET</b>	<b>MAX INT</b>	<b>SIZE</b>	<b>cc/rev</b>	
76H-HT6ZC10P	003	10.8	1-1/2" BSP	1" BSP	280 Bar	003	10.8	
76H-HT6ZC17P	005	17.2	1-1/2" BSP	1" BSP	280 Bar	005	17.2	
76H-HT6ZC21P	006	21.3	1-1/2" BSP	1" BSP	280 Bar	006	21.3	
76H-HT6ZC26P	008	26.4	1-1/2" BSP	1" BSP	280 Bar	008	26.4	
76H-HT6ZC31P	010	31.8	1-1/2" BSP	1" BSP	280 Bar	010	31.8	
76H-HT6ZC37P	012	37.1	1-1/2" BSP	1" BSP	280 Bar	012	37.1	
76H-HT6ZC46P	014	46.0	1-1/2" BSP	1" BSP	280 Bar	014	46.0	
76H-HT6ZC58P	017	58.3	1-1/2" BSP	1" BSP	281 Bar	017	58.3	
76H-HT6ZC63P	020	63.8	1-1/2" BSP	1" BSP	280 Bar	020	63.8	
76H-HT6ZC70P	022	70.3	1-1/2" BSP	1" BSP	280 Bar	022	70.3	
76H-HT6ZC79P	025	79.3	1-1/2" BSP	1" BSP	280 Bar	025	79.3	
76H-HT6ZC88P	028	88.8	1-1/2" BSP	1" BSP	210 Bar	028	88.8	
76H-HT6ZC100P	031	100.0	1-1/2" BSP	1" BSP	210 Bar	031	100.0	
	<b>SPARE PARTS</b>							
76H-HT6GZC10CR	CARTRIDGE KIT 10.8cc ; CAM RING CODE 003							
76H-HT6GZC17CR	CARTRIDGE KIT 17.3cc ; CAM RING CODE 005							
76H-HT6GZC21CR	CARTRIDGE KIT 21.3cc ; CAM RING CODE 006							
76H-HT6GZC26CR	CARTRIDGE KIT 26.4cc ; CAM RING CODE 008							
76H-HT6GZC31CR	CARTRIDGE KIT 31.8cc ; CAM RING CODE 010							
76H-HT6GZC37CR	CARTRIDGE KIT 37.1cc ; CAM RING CODE 012							
76H-HT6GZC46CR	CARTRIDGE KIT 46.0cc ; CAM RING CODE 014							
76H-HT6GZC58CR	CARTRIDGE KIT 58.3cc ; CAM RING CODE 017							
76H-HT6GZC63CR	CARTRIDGE KIT 63.8cc ; CAM RING CODE 020							
76H-HT6GZC70CR	CARTRIDGE KIT 70.3cc ; CAM RING CODE 022							
76H-HT6GZC79CR	CARTRIDGE KIT 79.3cc ; CAM RING CODE 025							
76H-HT6GZC88CR	CARTRIDGE KIT 88.8cc ; CAM RING CODE 028							
76H-HT6GZC100CR	CARTRIDGE KIT 100cc ; CAM RING CODE 031							
76H-HT6ZCSHAF	DRIVE SHAFT SINGLE							
76H-HT6ZCBEAR	BEARING KIT SINGLE							
76H-HT6ZCSKIT	SEAL KIT SINGLE							



HT6ZC

Part Number	P.T.O. VANE PUMPS CAST IRON								RETAIL:
									13-07-2023
	<b><u>TYPE : DOUBLE ; D.I.N. MOUNT ; 4 BOLT</u></b>								
	<b><u>HOF HIGH PRESSURE VANE PUMP</u></b>								
	<b><u>MOUNTINGS : DIN 4 BOLT 32 DIFFERENT PORT POSITIONS</u></b>								
	<b><u>SHAFTS : DIN 5462 8 SPLINE</u></b>								
	<b><u>ROTATION : ( R ) CLOCKWISE</u></b>								
	<b><u>( L ) ANTI CLOCKWISE</u></b>								
	<b><u>PART No : HT6GCC - 70 - 70 - R</u></b>								
	<b><u>PART No BREAKDOWN : SERIES; HT6GCC DISP; 70cc / 70cc R; RIGHT HAND ROTATION</u></b>								
	<b><u>DOUBLE PUMPS</u></b>								
	<b><u>TECHNICAL DATA</u></b>								
	DISP	CAM RING	PRESSURE	PORT	P0RTS	PRESSURE	CAM RING	DISP	
	cc/rev X P1	SIZE X P1	MAX CONT	INLET X 1	OUTLET x 2	MAX CONT	SIZE X P2	cc/rev X P2	
76H-HT6GCC70-70	70.3	022	240 Bar	2-1/2" S/F	1" S/F	240 Bar	022	70.3	
76H-HT6GCC70-XX	70.3	022	240 Bar	2-1/2" S/F	1" S/F	240 Bar	XX	XX	
76H-HT6GCC80-XX	79.3	025	210 Bar	2-1/2" S/F	1" S/F	240 Bar	XX	XX	

	<b><u>FRONT PUMP CARTRIGE KIT P1</u></b>								
	<b><u>TECHNICAL DATA</u></b>								
	CAM RING	DISP	PRESSURE		PRESSURE	CAM RING	DISP		
	SIZE	cc/rev	MAX CONT		MAX CONT	SIZE	cc/rev		
76H-HT6GCCP1-70	022	70.3	240 Bar		240 Bar	022	70,3		
76H-HT6GCCP1-80	025	79.3	210 Bar		210 Bar	025	79,3		

	<b><u>REAR PUMP CARTRIDGE KIT P2</u></b>								
	<b><u>TECHNICAL DATA</u></b>								
	CAM RING	DISP	PRESSURE		PRESSURE	CAM RING	DISP		
	SIZE	cc/rev	MAX CONT		MAX CONT	SIZE	cc/rev		
76H-HT6GCCP2-10	003	10.8	240 Bar		240 Bar	003	10.8		
76H-HT6GCCP2-17	006	17.2	240 Bar		240 Bar	005	17.2		
76H-HT6GCCP2-32	010	31.8	240 Bar		240 Bar	010	31.8		
76H-HT6GCCP2-46	014	46.0	240 Bar		240 Bar	014	46.0		
76H-HT6GCCP2-58	017	58.3	240 Bar		240 Bar	017	58.3		
76H-HT6GCCP2-70	022	70.3	210 Bar		210 Bar	022	70.3		

	<b><u>SPARE PARTS</u></b>							
76H-HT6GCCSHAF	DRIVE SHAFT DOUBLE							
76H-HT6GCCBEAR	BEARING KIT DOUBLE							
76H-HT6GCCSKIT	SEAL KIT DOUBLE							

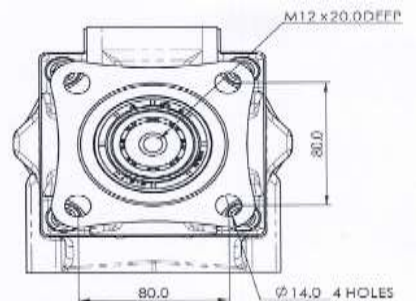
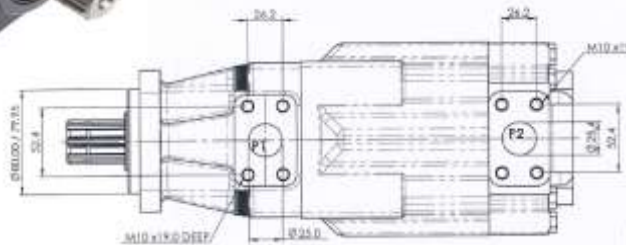

HT6GCC

<b>PUMPS VANE</b>		RETAIL:
		13-04-2023
	<b>MODEL VQ VANE PUMP CARTRIDGES</b> ( DIRECT SWOP WITH VICKERS )	
	<b>CARTRIDGE KIT 20VQ SERIES</b>	
77H-20VQ-5	5 GALLON CARTRIDGE KIT	
77H-20VQ-8	8 GALLON CARTRIDGE KIT	
77H-20VQ-11	11 GALLON CARTRIDGE KIT	
77H-20VQ-12	12 GALLON CARTRIDGE KIT	
77H-20VQ-14	14 GALLON CARTRIDGE KIT	
	<b>CARTRIDGE KIT 25VQ SERIES</b>	
77H-25VQ-12	12 GALLON CARTRIDGE KIT	
77H-25VQ-14	14 GALLON CARTRIDGE KIT	
77H-25VQ-17	17 GALLON CARTRIDGE KIT	
77H-25VQ-21	21 GALLON CARTRIDGE KIT	
	<b>CARTRIDGE KIT 35VQ SERIES</b>	
77H-35VQ-25	25 GALLON CARTRIDGE KIT	
77H-35VQ-30	30 GALLON CARTRIDGE KIT	
77H-35VQ-35	35 GALLON CARTRIDGE KIT	
77H-35VQ-38	38 GALLON CARTRIDGE KIT	
	<b>CARTRIDGE KIT 45VQ SERIES</b>	
77H-45VQ-42	42 GALLON CARTRIDGE KIT	
77H-45VQ-50	50 GALLON CARTRIDGE KIT	
77H-45VQ-60	60 GALLON CARTRIDGE KIT	
	<b>SHAFT SEALS PRIMARY ( INSIDE PUMP )</b>	
77H-20VQSP	20VQ	
77H-25VQSP	25VQ	
77H-35VQSP	35VQ	
77H-45VQSP	45VQ	
	<b>SHAFT SEALS SECONDARY ( OUTSIDE PUMP )</b>	
77H-25VQSS	25/20VQ	
77H-35VQSS	35VQ	
77H-45VQSS	45VQ	
	<b>SHAFT BEARINGS</b>	
77H-20VQSB	20VQ	
77H-25VQSB	25VQ	
77H-35VQSB	35VQ	
77H-45VQSB	45VQ	
	<b>PUMP SHAFT KIT : SPIROLOCK , WASHER AND SNAPRING</b>	
77H-20VQSL	20VQ	
77H-25VQSL	25VQ	
77H-35VQSL	35VQ	
77H-45VQSL	45VQ	
	<b>PUMP SEAL KIT SINGLE</b>	
77H-20VQSK	20VQ	
77H-25VQSK	25VQ	
77H-35VQSK	35VQ	
77H-45VQSK	45VQ	
	<b>PUMP SEAL KIT DOUBLE</b>	
77H-2520VQSKD	2520VQ	
77H-3520VQSKD	3520VQ	
77H-3525VQSKD	3525VQ	
77H-4520VQSKD	4520VQ	
77H-4525VQSKD	4525VQ	
77H-4535VQSKD	4535VQ	
	<b>PLEASE NOTE: ALL O.E.M. NAMES OR NUMBERS ARE FOR REFERENCE USE ONLY</b>	<b>PAGE R 1</b>

Part Number	<b>PUMPS VANE</b>		RETAIL:
	<b>MODEL VQ VANE PUMP SHAFTS</b> ( DIRECT SWOP WITH VICKERS )		13-04-2023
	<b>SHAFTS 20VQ SERIES SINGLE</b>		
77H-20VQ-1	PARR / KEY 7/8" SAE A SINGLE PUMP		
77H-20VQ-151	13 SPLINE 7/8" SAE B SINGLE PUMP		
	<b>SHAFTS 25VQ SERIES SINGLE</b>		
77H-25VQ-1	PARR / KEY 7/8" SAE A SINGLE PUMP		
77H-25VQ-86	PARR / KEY 1" SAE BB SINGLE PUMP		
77H-25VQ-11	13 SPLINE 7/8" SAE B SINGLE PUMP		
	<b>SHAFTS 35VQ SERIES SINGLE</b>		
77H-35VQ-1	PARR / KEY 1-1/4" SAE C SINGLE PUMP		
77H-35VQ-11	14 SPLINE 1-1/4" SAE C SINGLE PUMP		
77H-35VQ-19	14 SPLINE 1-1/4" SAE C DOUBLE PUMP ( TO BE USED WITH CAT S.E.C. ONLY )		
	<b>SHAFTS 45VQ SERIES SINGLE</b>		
77H-45VQ-1	PARR / KEY 1-1/4" SAE C SINGLE PUMP		
77H-45VQ-11	14 SPLINE 1-1/4" SAE C SINGLE PUMP		
77H-45VQ-19	14 SPLINE 1-1/4" SAE C DOUBLE PUMP ( TO BE USED WITH CAT S.E.C. ONLY )		
	<b>SHAFTS 2520VQ SERIES DOUBLE</b>		
77H-2520VQ-1	PARR / KEY 7/8" SAE A DOUBLE PUMP		
77H-2520VQ-86	PARR / KEY 1" SAE BB DOUBLE PUMP		
77H-2520VQ-11	13 SPLINE 7/8" SAE B DOUBLE PUMP		
77H-2520VQ-19	14 SPLINE 1-1/4" SAE C DOUBLE PUMP ( TO BE USED WITH CAT S.E.C. ONLY )		
	<b>SHAFTS 3520VQ SERIES DOUBLE</b>		
77H-3520VQ-1	PARR / KEY 1-1/4" SAE C DOUBLE PUMP		
77H-3520VQ-11	14 SPLINE 1-1/4" SAE C DOUBLE PUMP		
77H-3520VQ-19	14 SPLINE 1-1/4" SAE C DOUBLE PUMP ( TO BE USED WITH CAT S.E.C. ONLY )		
	<b>SHAFTS 3525VQ SERIES DOUBLE</b>		
77H-3525VQ-1	PARR / KEY 1-1/4" SAE C DOUBLE PUMP		
77H-3525VQ-11	14 SPLINE 1-1/4" SAE C DOUBLE PUMP		
77H-3525VQ-19	14 SPLINE 1-1/4" SAE C DOUBLE PUMP ( TO BE USED WITH CAT S.E.C. ONLY )		
	<b>SHAFTS 4520VQ SERIES DOUBLE</b>		
77H-4520VQ-1	PARR / KEY 1-1/4" SAE C DOUBLE PUMP		
77H-4520VQ-11	14 SPLINE 1-1/4" SAE C DOUBLE PUMP		
	<b>SHAFTS 4525VQ SERIES DOUBLE</b>		
77H-4525VQ-1	PARR / KEY 1-1/4" SAE C DOUBLE PUMP		
77H-4525VQ-11	14 SPLINE 1-1/4" SAE C DOUBLE PUMP		
77H-4525VQ-19	14 SPLINE 1-1/4" SAE C DOUBLE PUMP ( TO BE USED WITH CAT S.E.C. ONLY )		
	<b>SHAFTS 4535VQ SERIES DOUBLE</b>		
77H-4535VQ-1	PARR / KEY 1-1/4" SAE C DOUBLE PUMP		
77H-4535VQ-11	14 SPLINE 1-1/4" SAE C DOUBLE PUMP		
77H-4535VQ-86	PARR / KEY 1-1/2" SAE C DOUBLE PUMP		
77H-4535VQ-19	14 SPLINE 1-1/4" SAE C DOUBLE PUMP ( TO BE USED WITH CAT S.E.C. ONLY )		
			
<b>PLEASE NOTE: ALL O.E.M. NAMES OR NUMBERS ARE FOR REFERENCE USE ONLY</b>			<b>PAGE R 2</b>



<u>Part Number</u>	<b>PUMPS VANE</b>					<b>RETAIL:</b> 13-04-2023
	<b><u>MODEL VQ VANE PUMPS</u></b> ( DIRECT SWOP WITH VICKERS )					
	<b><u>COMPLETE PUMPS SINGLE</u></b>					
77H-20VQ	5 TO 14 GALLON SHAFT PARR KEY 7/8" OR 13 SPLINE SPIGOT 4" 2 BOLT					
77H-25VQ	12 TO 21 GALLON SHAFT PARR KEY 7/8" OR 1" OR 13 SPLINE SPIGOT 4" 2 BOLT					
77H-35VQ	25 TO 38 GALLON SHAFT PARR KEY 1-1/4" OR 14 SPLINE 11/4" SPIGOT 5" 2 BOLT					
77H-45VQ	42 TO 60 GALLON SHAFT PARR KEY 1-1/4" OR 14 SPLINE 11/4" SPIGOT 5" 2 BOLT					
77H-2520VQ	12-21 TO 5-14 GALLON SHAFT PARR KEY 7/8" AND 1" OR 13 SPLINE SPIGOT 4" 2 BOLT					
77H-3520VQ	25-38 TO 5-14 GALLON SHAFT PARR KEY 1-1/4" OR 14 SPLINE 1-1/4" SPIGOT 5" 2 BOLT					
77H-3525VQ	25-38 TO 12-21 GALLON SHAFT PARR KEY 1-1/4" OR 14 SPLINE 1-1/4" SPIGOT 5" 2 BOLT					
77H-4520VQ	42-60 TO 5-14 GALLON SHAFT PARR KEY 1-1/4" OR 14 SPLINE 1-1/4" SPIGOT 5" 2 BOLT					
77H-4525VQ	42-60 TO 12-21 GALLON SHAFT PARR KEY 1-1/4" OR 14 SPLINE 1-1/4" SPIGOT 5" 2 BOLT					
77H-4535VQ	42-60 TO 25-38 GALLON SHAFT PARR KEY 1-1/4" OR 14 SPLINE 1-1/4" SPIGOT 5" 2 BOLT					
	<b><u>HOW TO IDENTIFY PUMP SERIES BY MEASURING CAM RING OD IN mm</u></b>					
	20VQ CAM RING OD 82.6 mm					
	25VQ CAM RING OD 96.8 mm					
	35VQ CAM RING OD 114.3 mm					
	45VQ CAM RING OD 133.40 mm					
	<b><u>TECHNICAL SPECIFICATIONS</u></b>					
	<b><u>MODEL</u></b>	<b><u>FLOW @ 1200RPM US GAL</u></b>	<b><u>CC/REV</u></b>	<b><u>MAX SPEED RPM</u></b>	<b><u>MAX PRESS BAR</u></b>	
	20VQ	5	18	2700	206	
	20VQ	8	27	2700	206	
	20VQ	11	36	2700	206	
	20VQ	12	39	2700	158	
	20VQ	14	45	2700	138	
	<b><u>MODEL</u></b>	<b><u>FLOW @ 1200RPM US GAL</u></b>	<b><u>CC/REV</u></b>	<b><u>MAX SPEED RPM</u></b>	<b><u>MAX PRESS BAR</u></b>	
	25VQ	12	40	2700	206	
	25VQ	14	45	2700	206	
	25VQ	17	55	2500	206	
	25VQ	21	67	2500	206	
	<b><u>MODEL</u></b>	<b><u>FLOW @ 1200RPM US GAL</u></b>	<b><u>CC/REV</u></b>	<b><u>MAX SPEED RPM</u></b>	<b><u>MAX PRESS BAR</u></b>	
	35VQ	25	81	2500	206	
	35VQ	30	97	2500	206	
	35VQ	35	112	2400	206	
	35VQ	38	121	2400	206	
	<b><u>MODEL</u></b>	<b><u>FLOW @ 1200RPM US GAL</u></b>	<b><u>CC/REV</u></b>	<b><u>MAX SPEED RPM</u></b>	<b><u>MAX PRESS BAR</u></b>	
	45VQ	42	138	2200	172	
	45VQ	50	162	2200	172	
	45VQ	60	193	2200	172	





<u>Part Number</u>	<b>PUMPS VANE</b>					<b>RETAIL:</b>
	<b><u>MODEL V10, V20 &amp; VTM 42 VANE PUMPS</u></b> ( DIRECT SWOP WITH VICKERS )					<b>01-10-2022</b>
77H-V10	PUMP SINGLE					
77H-V20	PUMP SINGLE					
77H-V10P	PUMP SINGLE PRIORITY VALVE COVER					
77H-V20P	PUMP SINGLE PRIORITY VALVE COVER					
77H-V10F	PUMP SINGLE FLOW CONTROL COVER					
77H-V20F	PUMP SINGLE FLOW CONTROL COVER					
77H-V2010	PUMP DOUBLE					
77H-V2020	PUMP DOUBLE					
	<b><u>MODEL V 10 P VANE PUMP UNIT GALLION GRADER STEER PUMP</u></b>					
77H-V10P1S7K11	V10-P1S7K11D7D					
	SPECS : SPIGOT 3-1/4" 2 BOLT PORTS 1" SAE & 1/2" SAE SECONDARY 3/8" SAE PRIMARY					
	DELIVERY 11 GAL PRIORITY 7 GAL PRESSURE 70 BAR SHAFT 9 TOOTH ROTATION C/W					
	<b><u>MODEL V 20 VANE PUMP UNIT DIRECT SWOP ON PART NUMBER</u></b>					
77H-V20-1P11P1C	V20-1P11P-1C					
	SPECS : SPIGOT 3-1/4" 2 BOLT PORTS 1-1/4" NPT & 3/4" NPT DELIVERY 11 GAL					
	SHAFT 3/4" PARR KEY ROTATION C/W					
	<b><u>MODEL VTM 42 VANE PUMP UNIT DIRECT SWOP ON PART NUMBER</u></b>					
77H-VTM425040	VTM-42-50-40-15-NO-R1-14					
	SPECS : SPIGOT 3-1/4" 2 BOLT DELIVERY 5 GAL CONTROLLED FLOW 4 GAL RELIEF 15 BAR					
	ROTATION C/W SHAFT 7/8" PARR KEY + THREAD PRESSURE PORT 1/2" SAE "O"					
77H-VTM-TANK	VTM TANK					
	<b>TECHNICAL SPECIFICATIONS</b>					
	<b>MODEL</b>	<b>FLOW @ 1200RPM US GAL</b>	<b>CC/REV</b>	<b>MAX SPEED RPM</b>	<b>MAX PRESS BAR</b>	
	V10	1	3.3	4800	172	
	V10	2	6.6	4500	172	
	V10	3	9.8	4000	172	
	V10	4	13.1	3400	172	
	V10	5	16.4	3200	172	
	V10	6	19.5	3000	152	
	V10	7	22.8	2800	138	
	<b>MODEL</b>	<b>FLOW @ 1200RPM US GAL</b>	<b>CC/REV</b>	<b>MAX SPEED RPM</b>	<b>MAX PRESS BAR</b>	
	V20	6	19.5	3400	172	
	V20	7	22.8	3000	172	
	V20	8	26.5	2800	172	
	V20	9	29.7	2800	172	
	V20	11	36.4	2500	172	
	V20	12	39.0	2400	152	
	V20	13	42.4	2400	152	



Part Number	VANE MOTORS				RETAIL:	
					01-10-2022	
	<b>MOTOR SERIES ; 25HM ; 35HM ; 45HM</b>					
	<b>25HM COMPLETE MOTORS</b>					
77H-25HM30A1C	25 HM 30 A - 1 C	RING SIZE 29.0cc	PARRALLEL SHAFT 7/8" OR 13 TOOTH	SPIGOT 4"		
77H-25HM42A1C	25 HM 42 A - 1 C	RING SIZE 43.9cc	PARRALLEL SHAFT 7/8" OR 13 TOOTH	SPIGOT 4"		
77H-25HM55A1C	25 HM 55 A - 1 C	RING SIZE 57.7cc	PARRALLEL SHAFT 7/8" OR 13 TOOTH	SPIGOT 4"		
77H-25HM65A1C	25 HM 65 A - 1 C	RING SIZE 68.7cc	PARRALLEL SHAFT 7/8" OR 13 TOOTH	SPIGOT 4"		
	<b>35HM COMPLETE MOTORS</b>					
77H-35HM80A1C	35 HM 80 A - 1 C	RING SIZE 83.6cc	PARRALLEL SHAFT 1-1/4" OR 14 TOOTH	SPIGOT 5"		
77H-35HM95A1C	35 HM 95 A - 1 C	RING SIZE 100.3cc	PARRALLEL SHAFT 1-1/4" OR 14 TOOTH	SPIGOT 5"		
77H-35HM115A1C	35 HM 115 A - 1 C	RING SIZE 121.9cc	PARRALLEL SHAFT 1-1/4" OR 14 TOOTH	SPIGOT 5"		
	<b>45HM COMPLETE MOTORS</b>					
77H-45HM130A1C	45 HM 130 A - 1 C	RING SIZE 138.0cc	PARRALLEL SHAFT 1-1/4" OR 14 TOOTH	SPIGOT 5"		
77H-45HM155A1C	45 HM 155 A - 1 C	RING SIZE 163.2cc	PARRALLEL SHAFT 1-1/4" OR 14 TOOTH	SPIGOT 5"		
77H-45HM185A1C	45 HM 185 A - 1 C	RING SIZE 193.2cc	PARRALLEL SHAFT 1-1/4" OR 14 TOOTH	SPIGOT 5"		
	<b>CARTRIDGE KITS</b>					
77H-25HM-30	25HM RING SIZE, 30					
77H-25HM-42	25HM RING SIZE, 42					
77H-25HM-55	25HM RING SIZE, 55,					
77H-25HM-65	25HM RING SIZE, 65					
77H-35HM-80	35HM RING SIZE, 80					
77H-35HM-95	35HM RING SIZE, 95,					
77H-35HM-115	35HM RING SIZE, 115					
77H-45HM-130	45HM RING SIZE, 130					
77H-45HM-155	45HM RING SIZE, 155					
77H-45HM-185	45HM RING SIZE, 185					
	<b>SHAFTS</b>					
77H-25HMS-11	MOTOR SHAFT SPLINED 25 HM - 11 ( 13 TOOTH SAE B )					
77H-35HMS-11	MOTOR SHAFT SPLINED 35 HM - 11 ( 14 TOOTH SAE C )					
77H-45HMS-11	MOTOR SHAFT SPLINED 45 HM - 11 ( 14 TOOTH SAE C )					
	<b>SHAFT SEAL</b>					
77H-25HM-SS	25HM SHAFT SEAL					
77H-35HM-SS	35HM SHAFT SEAL					
77H-45HM-SS	45HM SHAFT SEAL					
	<b>NOTES:</b>					
MOTORS ARE BI ROTATION , CAN BE RUN IN SERIES, HIGHER SPEEDS CAN REACHED IF						
WORKING PRESSURE IS LOWERED, CASE DRAIN MUST BE NO MORE THAN MAX 0.7 bar						
	<b>PORTS</b>					
	SERIES	BODY PORT	COVER PORT	CASE DRAIN		
	25HM	1-1/4" S/F unc	1-1/4" S/F unc	1/4" NPT		
	35HM	1-1/2" S/F unc	1-1/2" S/F unc	3/8" NPT		
	45HM	2" S/F unc	2" S/F unc	1/2" NPT		
	<b>SPECIFICATIONS</b>					
	MODEL SERIES	TORQUE Nm/6.9bar (lb in/100psi)	DISPLACEMENT cc/r (cc/r)	FLOW INPUT @ 1200rpm L/min (Us/gal)	MAX SPEED & PRESSURE CONTINUOUS	Kg
	25HM	3.3 (30)	29.0 (1.77)	34.8 (9.19)	2600 r/min @ 155 bar	18
		4.7 (42)	43.9 (2.68)	52.6 (13.9)	2600 r/min @ 155 bar	18
		6.2 (55)	57.7 (3.52)	69.3 (18.3)	2600 r/min @ 155 bar	18
		7.3 (65)	68.7 (4.19)	82.5 (21.8)	2600 r/min @ 155 bar	18
	35HM	9.0 (80)	83.6 (5.10)	100.3 (26.5)	2600 r/min @ 155 bar	29
		10.7 (95)	100.3 (6.12)	120.4 (31.8)	2600 r/min @ 155 bar	29
		13.0 (115)	121.9 (7.44)	146.1 (38.6)	2600 r/min @ 155 bar	29
	45HM	14.7 (130)	138.0 (8.42)	165.4 (43.7)	2600 r/min @ 155 bar	39
		17.5 (155)	163.2 (9.96)	195.7 (51.7)	2600 r/min @ 155 bar	39
		20.9 (185)	193.2 (11.79)	232.0 (61.3)	2600 r/min @ 155 bar	39
<b>PLEASE NOTE: ALL O.E.M. NAMES OR NUMBERS ARE FOR REFERENCE USE ONLY</b>						
						<b>PAGE R 6</b>

## PUMPS PISTON

PUMP ORDERING CODE	TK	A10VS	O	71	DFR	31	R	P	P	A	12	N00					
<b>AXIAL PISTON UNIT</b>																	
SWASH PLATE VARIABLE PUMP INDUSTRIAL		A10VS															
<b>MODES OF OPERATION</b>																	
PUMP OPEN CIRCUIT											X						
<b>SIZE</b>																	
DISPLACEMENT (cc/rev)	18	28	45	71	100	140											
<b>CONTROL DEVICES</b>																	
PRESSURE CONTROL	X	X	X	X	X	X	DR										
G-REMOTE CONTROL	X	X	X	X	X	X	DRG										
PRESSURE AND FLOW CONTROL	X	X	X	X	X	X	DFR										
X CHANNEL PLUGGED	X	X	X	X	X	X	DFR1										
PRESSURE FLOW AND POWER CONTROL		X	X	X	X		DFLR										
<b>SERIES</b>																	
SERIES											31						
<b>DIRECTION OF ROTATION</b>																	
VIEWED ON DRIVE SHAFT					CLOCKWISE			R									
VIEWED ON DRIVE SHAFT					ANTI CLOCKWISE			L									
<b>SEALS</b>																	
BUNA-N											P						
FPM (FLUOROCARBON)											V						
<b>SHAFT END</b>																	
	18	28	45	71	100	140											
SPLINED SHAFT SAE INCH	3/4"-11T	7/8"-13T	1"-15T	1-1/4"-14T	1-1/2"-17T	1-3/4"-13T	S										
SPLINED SHAFT SAE INCH SHAFT REINFORCED THRU - DRIVE		7/8"-13T	1"-15T	1-1/4"-14T			R										
SPLINED SHAFT SAE INCH SMALLER SIZE NO THRU - DRIVE			7/8"-13T		1-1/4"-14T		U										
SPLINED SHAFT SAE INCH SHAFT REINFORCED U TYPE SHAFT			7/8"-13T		1-1/4"-14T		W										
PARALLEL SHAFT SAE INCH KEYED SHAFT	3/4"	7/8"	1"	1-1/4"	1-1/2"	1-3/4"	K										
PARALLEL SHAFT DIN METRIC KEYED SHAFT	18mm	22mm	25mm	32mm	40mm	45mm	P										
<b>MOUNTING FLANGE</b>																	
	18	28	45	71	100	140											
SAE 2 HOLE INCH	3-3/4"	4"	4"	5"	5"		C										
SAE 4 HOLE INCH						6"	D										
ISO 2 HOLE METRIC	80mm	100mm	100mm	125mm	125mm	180mm	A										
<b>SERVICE PORTS</b>																	
	18	28	45	71	100	140											
REAR PORTS UNC THREADS		x	x	x	x	x	61	ports pos 61, 11, 91, and 41 only for version without 41 through drive									
OPPOSITE SIDE PORTS UNC THREADS	X	X	X	X	X	X	62										
REAR PORTS METRIC THREADS		X	X	X	X	X	11										
OPPOSITE SIDE PORTS METRIC THREADS	X	X	X	X	X	X	12										
REAR PORTS UNC THREADS				X			91										
OPPOSITE SIDE PORTS UNC THREADS				X			92										
REAR PORTS METRIC THREADS				X			41										
OPPOSITE SIDE PORTS METRIC THREADS				X			42										
<b>THRU - DRIVE REAR COVER</b>																	
	18	28	45	71	100	140											
STANDARD COVER WITHOUT THROUGH DRIVE		X	X	X	X	X	N00										
SAE A 3-1/4" 2 BOLT ADAPTOR 9 SPLINE		X	X	X	X	X	K01										
SAE A 3-1/4" 2 BOLT ADAPTOR 11 SPLINE		X	X	X	X	X	K52										
SAE B 4" 2 BOLT ADAPTOR 13 SPLINE		X	X	X	X	X	K02 / K68										
SAE B 4" 2 BOLT ADAPTOR 15 SPLINE		X	X	X	X	X	K04										
SAE C 5" 2 BOLT ADAPTOR 14 SPLINE				X	X	X	K07										
SAE D 6" 4 BOLT ADAPTOR 14 SPLINE						X	K17										



Part Number	PUMPS PISTON							RETAIL:
								01-10-2022
	<b>SINGLE A 10V 31 SERIES IMPERIAL (SPIGOT &amp; SHAFT C/W / CCW)</b>							
	<b>STANDARD PARRALLEL KEY SHAFTS (CODE K)</b>							
78H-A10V18-IPR	A10VS O 18 DFR / 31 R - P K C 62 NOO	PARRALLEL SHAFT 3/4"	SPIGOT 3-1/4"					
78H-A10V28-IPR	A10VS O 28 DFR / 31 R - P K C 62 NOO	PARRALLEL SHAFT 7/8"	SPIGOT 4"					
78H-A10V45-IPR	A10VS O 45 DFR / 31 R - P K C 62 NOO	PARRALLEL SHAFT 1"	SPIGOT 4"					
78H-A10V71-IPR	A10VS O 71 DFR / 31 R - P K C 62 NOO	PARRALLEL SHAFT 1-1/4"	SPIGOT 5"					
78H-A10V100-IPR	A10VS O 100 DFR / 31 R - P K C 62 NOO	PARRALLEL SHAFT 1-1/2"	SPIGOT 5"					
78H-A10V140-IPR	A10VS O 140 DFR / 31 R - P K D 62 NOO	PARRALLEL SHAFT 1- 3/4"	SPIGOT 6"					
	<b>STANDARD SPLINE SHAFTS (CODE S)</b>							
78H-A10V18-ISR	A10VS O 18 DFR / 31 R - P S C 62 NOO	SPLINE SHAFT 11 SPLINE	SPIGOT 3-1/4"					
78H-A10V28-ISR	A10VS O 28 DFR / 31 R - P S C 62 NOO	SPLINE SHAFT 13 SPLINE	SPIGOT 4"					
78H-A10V45-ISR	A10VS O 45 DFR / 31 R - P S C 62 NOO	SPLINE SHAFT 15 SPLINE	SPIGOT 4"					
78H-A10V71-ISR	A10VS O 71 DFR / 31 R - P S C 62 NOO	SPLINE SHAFT 14 SPLINE	SPIGOT 5"					
78H-A10V100-ISR	A10VS O 100 DFR / 31 R - P S C 62 NOO	SPLINE SHAFT 17 SPLINE	SPIGOT 5"					
78H-A10V140-ISR	A10VS O 140 DFR / 31 R - P S D 62 NOO	SPLINE SHAFT 13 SPLINE	SPIGOT 6"					
	<b>DOUBLE A 10V 31 SERIES IMPERIAL (THRU-DRIVE ADD-ON C/W / CCW)</b>							
78H-A10V28AD3R	A10VS O 28 DFR / 31 R - 62 ADD-ON SAE A 3-1/4"	(K01 / 9T) (K52 / 11T)						
78H-A10V28AD4R	A10VS O 28 DFR / 31 R - 62 ADD-ON SAE B 4"	(K68 ; K02 / 13T) (K04 / 15T)						
78H-A10V45AD3R	A10VS O 45 DFR / 31 R - 62 ADD-ON SAE A 3-1/4"	(K01 / 9T) (K52 / 11T)						
78H-A10V45AD4R	A10VS O 45 DFR / 31 R - 62 ADD-ON SAE B 4"	(K68 ; K02 / 13T) (K04 / 15T)						
78H-A10V71AD3R	A10VS O 71 DFR / 31 R - 62 ADD-ON SAE A 3-1/4"	(K01 / 9T) (K52 / 11T)						
78H-A10V71AD4R	A10VS O 71 DFR / 31 R - 62 ADD-ON SAE B 4"	(K68 ; K02 / 13T) (K04 / 15T)						
78H-A10V71AD5R	A10VS O 71 DFR / 31 R - 62 ADD-ON SAE C 5"	(K07 / 14T)						
78H-A10V100AD4R	A10VS O 100 DFR / 31 R - 62 ADD-ON SAE B 4"	(K68 ; K02 / 13T) (K04 / 15T)						
78H-A10V100AD5R	A10VS O 100 DFR / 31 R - 62 ADD-ON SAE C 5"	(K07 / 14T)						
78H-A10V140AD4R	A10VS O 140 DFR / 31 R - 62 ADD-ON SAE B 4"	(K68 ; K02 / 13T) (K04 / 15T)						
78H-A10V140AD5R	A10VS O 140 DFR / 31 R - 62 ADD-ON SAE C 5"	(K07 / 14T)						
	<b>SPECS: FOR THE ABOVE PUMPS</b>							
	MODEL	CC / REV	ROTATION	SHAFT	SPIGOT	MOUNT	SUCTION	PRESSURE
	A10VSO18	18	C / W	3/4" : 11T	3-1/4"	2 X BOLT	1" S/F	3/4" S/F
	A10VSO28	28	C / W	7/8" : 13T	4"	2 X BOLT	1-1/4" S/F	3/4" S/F
	A10VSO45	45	C / W	1" : 15T	4"	2 X BOLT	1-1/2" S/F	1" S/F
	A10VSO71	71	C / W	1-1/4" : 14T	5"	2 X BOLT	2" S/F	1" S/F
	A10VSO100	100	C / W	1-1/2" : 17T	5"	2 X BOLT	2-1/2" S/F	1-1/4" S/F-m*
	A10VSO140	140	C / W	1-3/4" : 13T	6"	4 X BOLT	2-1/2" S/F	1-1/4" S/F-m*
	ALL PORTS 3000 SERIES ; EXCEPT FOR 1-1/4" S/F-m* 6000 SERIES							
	<b>SPECS: FOR THE ABOVE PUMPS</b>							
	MODEL	PRESSURE	PRESSURE	INLET PRESSURE		SPEED	SPEED	WEIGHT
	CC/REV	RATED	CASING	MIN	MAX	MAX	MIN	Kg
	A10VSO18	280 Bar	2 Bar	0.8 Bar	30 Bar	3300 rpm	600 rpm	12
	A10VSO28	280 Bar	2 Bar	0.8 Bar	30 Bar	3000 rpm	600 rpm	15
	A10VSO45	280 Bar	2 Bar	0.8 Bar	30 Bar	2600 rpm	600 rpm	21
	A10VSO71	280 Bar	2 Bar	0.8 Bar	30 Bar	2200 rpm	600 rpm	33
	A10VSO100	280 Bar	2 Bar	0.8 Bar	30 Bar	2000 rpm	600 rpm	45
	A10VSO140	280 Bar	2 Bar	0.8 Bar	30 Bar	1800 rpm	600 rpm	60
								
PLEASE NOTE: ALL O.E.M. NAMES OR NUMBERS ARE FOR REFERENCE USE ONLY							PAGE S 2	









Part Number	<b>PUMPS PISTON</b>		RETAIL:
	<b>SINGLE A 10V 31 SERIES IMPERIAL (HORSE POWER CONTROL)</b>		01-10-2022
	<b>STANDARD PARRALLEL KEY SHAFTS</b>	<b>( CODE K )</b>	
78H-A1028DFLIR	A10VS O 28 DFLR / 31 R - P K C 62 NOO	PARRALLEL SHAFT 7/8" SPIGOT 4"	
78H-A1045DFLIR	A10VS O 45 DFLR / 31 R - P K C 62 NOO	PARRALLEL SHAFT 1" SPIGOT 4"	
78H-A1071DFLIR	A10VS O 71 DFLR / 31 R - P K C 62 NOO	PARRALLEL SHAFT 1-1/4" SPIGOT 5"	
78H-A10100DFLIR	A10VS O 100 DFLR / 31 R - P K C 62 NOO	PARRALLEL SHAFT 1-1/2" SPIGOT 5"	
78H-A10140DFLIR	A10VS O 140 DFLR / 31 R - P K C 62 NOO	PARRALLEL SHAFT 1-3/4" SPIGOT 6"	
	<b>CONNECTING BILLET OPTIONS</b>		
	<b>A10VSO 28 THRU - DRIVE BILLETS</b>		
78H-241-3601	BILLET ADAPTOR 9 SPLINE K01		
78H-1-3601B-SZ	BILLET ADAPTOR 11 SPLINE K52		
78H-241-3601A	BILLET ADAPTOR 13 SPLINE K02 / K68		
	<b>A10VSO 45 THRU - DRIVE BILLETS</b>		
78H-242-3601E	BILLET ADAPTOR 9 SPLINE K01		
78H-242-3601D	BILLET ADAPTOR 11 SPLINE K52		
78H-242-3601B	BILLET ADAPTOR 13 SPLINE K02 / K68		
78H-242-3601F	BILLET ADAPTOR 15 SPLINE K04		
	<b>A10VSO 71 THRU - DRIVE BILLETS</b>		
78H-243-3601	BILLET ADAPTOR 9 SPLINE K01		
78H-243-3601E	BILLET ADAPTOR 11 SPLINE K52		
78H-243-3601C	BILLET ADAPTOR 13 SPLINE K02 / K68		
78H-243-3601A	BILLET ADAPTOR 14 SPLINE K07		
78H-243-3601D	BILLET ADAPTOR 15 SPLINE K04		
	<b>A10VSO 100 THRU - DRIVE BILLETS</b>		
78H-244-3601	BILLET ADAPTOR 9 SPLINE K01		
78H-244-3601B	BILLET ADAPTOR 13 SPLINE K02 / K68		
78H-244-3601A	BILLET ADAPTOR 14 SPLINE K07		
78H-244-3601C	BILLET ADAPTOR 15 SPLINE K04		
	<b>A10VSO 140 THRU - DRIVE BILLETS</b>		
78H-245-3601F	BILLET ADAPTOR 9 SPLINE K01		
78H-245-3601D	BILLET ADAPTOR 13 SPLINE K02 / K68		
78H-245-3601B	BILLET ADAPTOR 14 SPLINE K07		
78H-245-3601C	BILLET ADAPTOR 15 SPLINE K04		
	<b>LABOUR OPTIONS</b>		
78H-A10V-LAB-01	TO SET UP ON TEST BENCH NEW SINGLE PUMP PRESSURES AND FLOW		
78H-A10V-LAB-02	TO SET UP ON TEST BENCH NEW DOUBLE PUMP PRESSURES AND FLOW		
78H-A10V-LAB-03	TO SET UP ON TEST BENCH USED SINGLE PUMP PRESSURES AND FLOW		
78H-A10V-LAB-04	TO SET UP ON TEST BENCH USED DOUBLE PUMP PRESSURES AND FLOW		
78H-A10V-LAB-05	TO SET UP ON TEST BENCH NEW DFLR CONTROLLED PUMP		
	<b>BILL OF MATERIAL FOR ROTATION CHANGE</b>		
	BACK COVER ; VALVE PLATE AND YOKE TO BE REPLACED		









<u>Part Number</u>	<b>PUMPS PISTON</b>	<b>RETAIL:</b>
	<b><u>A 10V 31 SERIES PISTON PUMP</u></b>	<b>01-10-2022</b>
	<b><u>A10VSO 18 SPARES</u></b>	
78H-240-3306	A10VSO 18 SEAL KIT	
78H-A10V18-ROT	A10VSO 18 ROTATING GROUP ASSEMBLY 18cc	
78H-240-1101	A10VSO 18 CYLINDER BLOCK	
78H-240-2100C	A10VSO 18 PISTON (9 PER SET)	
78H-240-1201	A10VSO 18 BARREL WASHER	
78H-240-1301	A10VSO 18 COIL SPRING	
78H-240-1401	A10VSO 18 PRESS PIN	
78H-240-1501	A10VSO 18 SNAP RING	
78H-240-4102A	A10VSO 18 BALL GUIDE	
78H-240-4111A	A10VSO 18 RETAINER PLATE	
78H-240-3704	A10VSO 18 SHAFT BIG BEARING FRONT	
78H-240-3704A	A10VSO 18 SHAFT SMALL BEARING REAR	
78H-240-4401	A10VSO 18 VALVE PLATE RIGHT HAND	
78H-240-4501	A10VSO 18 VALVE PLATE LEFT HAND	
78H-240-5220	A10VSO 18 SWASH PLATE RIGHT HAND	
78H-240-5320	A10VSO 18 SWASH PLATE LEFT HAND	
78H-240-5251	A10VSO 18 SADDLE BEARING	
78H-240-7102B	A10VSO 18 HEAD BLOCK RIGHT HAND SAE SINGLE SIDE PORT 62 N00	
78H-240-7103B	A10VSO 18 HEAD BLOCK LEFT HAND SAE SINGLE SIDE PORT 62 N00	
78H-240-3101K	A10VSO 18 3/4" P / KEY TYPE K	
78H-240-3201U	A10VSO 18 SHAFT 9 SPLINE TYPE U	
78H-240-3201S	A10VSO 18 SHAFT 11 SPLINE TYPE S	
78H-240-7300	A10VSO 18 CONTROL VALVE DR	
78H-240-7200	A10VSO 18 CONTROL VALVE DFR	
78H-240-7400	A10VSO 18 CONTROL VALVE DFR1	
78H-240-72-DRG	A10VSO 18 CONTROL VALVE DRG	
78H-240-7110	A10VSO 18 CONTROL PISTON ASSEMBLY	
78H-240-7120	A10VSO 18 COUNTER PISTON ASSEMBLY	
78H-240-7135	A10VSO 18 BIAS SPRING	
78H-240-7630A	A10VSO 18 ~ 100 0.8 ORIFICE DFR ADAPTER	
78H-240-SL-M6	A10VSO 18 ~ 100 DOUBLE HEAD PLUG SL-M6 A6VM160	
78H-240-B6X18	A10VSO 18 ~ 100 COLUMN PIN B6x18 GB/T119	
		
78H-241-3306	A10VSO 28 SEAL KIT	
78H-A10V28-ROT	A10VSO 28 ROTATING GROUP ASSEMBLY 28cc	
78H-241-1101	A10VSO 28 CYLINDER BLOCK	
78H-241-2100C	A10VSO 28 PISTON	
78H-241-1201	A10VSO 28 BARREL WASHER	
78H-241-1301	A10VSO 28 COIL SPRING	
78H-241-1401	A10VSO 28 PRESS PIN	
78H-241-1501	A10VSO 28 SNAP RING	
78H-241-4102F	A10VSO 28 BALL GUIDE	
78H-241-4111A	A10VSO 28 RETAINER PLATE	
78H-241-3704	A10VSO 28 SHAFT BIG BEARING FRONT	
78H-241-3704A	A10VSO 28 SHAFT SMALL BEARING REAR	
78H-241-4401	A10VSO 28 VALVE PLATE RIGHT HAND	
78H-241-4501	A10VSO 28 VALVE PLATE LEFT HAND	
78H-241-5220	A10VSO 28 SWASH PLATE RIGHT HAND	
78H-241-5320	A10VSO 28 SWASH PLATE LEFT HAND	
78H-241-5251	A10VSO 28 SADDLE BEARING	
78H-241-7102B	A10VSO 28 HEAD BLOCK RIGHT HAND SAE SINGLE SIDE PORT 62 N00	
78H-241-7103B	A10VSO 28 HEAD BLOCK LEFT HAND SAE SINGLE SIDE PORT 62 N00	
78H-241-7102C	A10VSO 28 RIGHT HAND REAR COVER / THRU - DRIVE 3-1/4" 2 BOLT SAE SIDE PORT 62 (K01 / K52)	
	<b>PLEASE NOTE: ALL O.E.M. NAMES OR NUMBERS ARE FOR REFERENCE USE ONLY</b>	<b>PAGE S 4</b>

Part Number	PUMPS PISTON		RETAIL: 01-10-2022
	<u>A 10V 31 SERIES PISTON PUMP</u>		
	<u>A10VSO 28 SPARES</u>		
78H-241-7103C	A10VSO 28 LEFT HAND REAR COVER / THRU - DRIVE 3-1/4" 2 BOLT SAE SIDE PORT 62 (K01 / K52)		
78H-241	A10VSO 28 RIGHT HAND REAR COVER / THRU - DRIVE 4" 2 BOLT SAE SIDE PORT 62 (K04 / K68)		
78H-241-7103E	A10VSO 28 LEFT HAND REAR COVER / THRU - DRIVE 4" 2 BOLT SAE SIDE PORT 62 (K04 / K68)		
78H-241-3601	A10VSO 28 BILLET ADAPTOR 9 SPLINE K01		
78H-1-3601B-SZ	A10VSO 28 BILLET ADAPTOR 11 SPLINE K52		
78H-241-3601A	A10VSO 28 BILLET ADAPTOR 13 SPLINE K02 / K68		
78H-241-3601F	A10VSO 28 BILLET ADAPTOR 15 SPLINE K04		
78H-241-3101K	A10VSO28 SHAFT 7/8" P / KEY TYPE K		
78H-241-3101D	A10V28 SHAFT 7/8" P/KEY / THRU/D TYPE K		
78H-241-3201C	A10VSO28 SHAFT 13 SPLINE TYPE S		
78H-241-3201B	A10V28 SHAFT 13 SPLINE / THRU/D TYPE S		
78H-240-7300	A10VSO28 CONTROL VALVE DR		
78H-240-7200	A10VSO28 CONTROL VALVE DFR		
78H-240-7400	A10VSO28 CONTROL VALVE DFR1		
78H-240-72-DRG	A10VSO28 CONTROL VALVE DRG		
78H-242-7800	A10VSO28 HORSE POWER CONTROLLER 7.5Kw		
78H-241-7110	A10VSO 28 CONTROL PISTON ASSEMBLY		
78H-241-7120	A10VSO 28 COUNTER PISTON ASSEMBLY		
78H-241-7135	A10VSO 28 BIAS SPRING		
78H-241-7630A	A10VSO 18 ~ 100 0.8 ORIFICE DFR ADAPTER		
78H-241-SL-M6	A10VSO 18 ~ 100 DOUBLE HEAD PLUG SL-M6 A6VM160		
78H-241-B6X18	A10VSO 18 ~ 100 COLUMN PIN B6x18 GB/T119		
	<u>A10VSO 45 SPARES</u>		
78H-242-3306	A10VSO 45 SEAL KIT		
78H-A10V45-ROT	A10VSO 45 ROTATING GROUP ASSEMBLY 45cc		
78H-242-1101	A10VSO 45 CYLINDER BLOCK		
78H-242-2100C	A10VSO 45 PISTON		
78H-242-1201	A10VSO 45 BARREL WASHER		
78H-242-1301	A10VSO 45 COIL SPRING		
78H-242-1401	A10VSO 45 PRESS PIN		
78H-242-1501	A10VSO 45 SNAP RING		
78H-242-4102F	A10VSO 45 BALL GUIDE		
78H-242-4111	A10VSO 45 RETAINER PLATE		
78H-242-3704	A10VSO 45 SHAFT BIG BEARING FRONT		
78H-242-3704A	A10VSO 45 SHAFT SMALL BEARING REAR		
78H-242-4401	A10VSO 45 VALVE PLATE RIGHT HAND		
78H-242-4501	A10VSO 45 VALVE PLATE LEFT HAND		
78H-242-5220	A10VSO 45 SWASH PLATE RIGHT HAND		
78H-242-5320	A10VSO 45 SWASH PLATE LEFT HAND		
78H-242-5251	A10VSO 45 SADDLE BEARING		
78H-242-7102B	A10VSO 45 HEAD BLOCK RIGHT HAND SAE SINGLE SIDE PORT 62 N00		
78H-242-7103B	A10VSO 45 HEAD BLOCK LEFT HAND SAE SINGLE SIDE PORT 62 N00		
78H-242-7102E	A10VSO 45 RIGHT HAND REAR COVER / THRU - DRIVE 3-1/4" 2 BOLT SAE SIDE PORT 62 (K01 / K52)		
78H-242-7103E	A10VSO 45 LEFT HAND REAR COVER / THRU - DRIVE 3-1/4" 2 BOLT SAE SIDE PORT 62 (K01 / K52)		
78H-242-7102C	A10VSO 45 RIGHT HAND REAR COVER / THRU - DRIVE 4" 2 BOLT SAE SIDE PORT 62 (K04 / K68)		
78H-242-7103C	A10VSO 45 LEFT HAND REAR COVER / THRU - DRIVE 4" 2 BOLT SAE SIDE PORT 62 (K04 / K68)		
78H-242-3601E	A10VSO 45 BILLET ADAPTOR 9 SPLINE K01		
78H-242-3601D	A10VSO 45 BILLET ADAPTOR 11 SPLINE K52		
78H-242-3601B	A10VSO 45 BILLET ADAPTOR 13 SPLINE K02 / K68		
78H-242-3601F	A10VSO 45 BILLET ADAPTOR 15 SPLINE K04		
78H-242-3101K	A10VSO 45 SHAFT 1" P / KEY TYPE K		
78H-242-3101D	A10VSO 45 SHAFT 1" P/KEY / THRU-DRIVE TYPE K		
78H-242-3201U	A10VSO 45 SHAFT 13 SPLINE TYPE U		
78H-242-3201D	A10VSO 45 SHAFT 13 SPLINE/THRU-DRIVE TYPE U		
78H-242-3201	A10VSO 45 SHAFT 15 SPLINE TYPE S		
78H-242-3201C	A10VSO 45 SHAFT 15 SPLINE / THRU-DRIVE TYPE S		
PLEASE NOTE: ALL O.E.M. NAMES OR NUMBERS ARE FOR REFERENCE USE ONLY			PAGE 5 5







Part Number	PUMPS PISTON		RETAIL:
			01-10-2022
	<u>A 10V 31 SERIES PISTON PUMP</u>		
	<u>A10VSO 45 SPARES</u>		
78H-240-7300	A10VSO 45 CONTROL VALVE DR		
78H-240-7200	A10VSO 45 CONTROL VALVE DFR		
78H-240-7400	A10VSO 45 CONTROL VALVE DFR1		
78H-240-72-DRG	A10VSO 45 CONTROL VALVE DRG		
78H-242-7800	A10VSO 45 HORSE POWER CONTROLLER 15Kw		
78H-242-7110	A10VSO 45 CONTROL PISTON ASSEMBLY		
78H-242-7120	A10VSO 45 COUNTER PISTON ASSEMBLY		
78H-242-7135	A10VSO 45 BIAS SPRING		
78H-242-7630A	A10VSO 18 ~ 100 0.8 ORIFICE DFR ADAPTER		
78H-242-SL-M6	A10VSO 18 ~ 100 DOUBLE HEAD PLUG SL-M6 A6VM160		
78H-242-B6X18	A10VSO 18 ~ 100 COLUMN PIN B6x18 GB/T119		
	<u>A10VSO 71 SPARES</u>		
78H-243-3306	A10VSO 71 SEAL KIT		
78H-A10V71-ROT	A10VSO 71 ROTATING GROUP ASSEMBLY 71cc		
78H-243-1101	A10VSO 71 CYLINDER BLOCK		
78H-243-2100C	A10VSO 71 PISTON (9 PER SET)		
78H-243-1201	A10VSO 71 BARREL WASHER		
78H-243-1301	A10VSO 71 COIL SPRING		
78H-243-1401	A10VSO 71 PRESS PIN		
78H-243-1501	A10VSO 71 SNAP RING		
78H-243-4102F	A10VSO 71 BALL GUIDE		
78H-243-4111	A10VSO 71 RETAINER PLATE		
78H-243-3704	A10VSO 71 SHAFT BIG BEARING FRONT		
78H-243-3704A	A10VSO 71 SHAFT SMALL BEARING REAR		
78H-243-4401	A10VSO 71 VALVE PLATE RIGHT HAND		
78H-243-4501	A10VSO 71 VALVE PLATE LEFT HAND		
78H-243-5220	A10VSO 71 SWASH PLATE RIGHT HAND		
78H-243-5320	A10VSO 71 SWASH PLATE LEFT HAND		
78H-243-5251	A10VSO 71 SADDLE BEARING		
78H-243-7104	A10VSO 71 HEAD BLOCK RIGHT HAND REAR PORTS		
78H-243-7105	A10VSO 71 HEAD BLOCK LEFT HAND REAR PORTS		
78H-243-7102B	A10VSO 71 HEAD BLOCK RIGHT HAND SAE SINGLE SIDE PORT 62 N00		
78H-243-7103B	A10VSO 71 HEAD BLOCK LEFT HAND SAE SINGLE SIDE PORT 62 N00		
78H-243-7102C	A10VSO 71 RIGHT HAND REAR COVER / THRU - DRIVE 3-1/4" 2 BOLT SAE SIDE PORT 62 (K01 / K52)		
78H-243-7103C	A10VSO 71 LEFT HAND REAR COVER / THRU - DRIVE 3-1/4" 2 BOLT SAE SIDE PORT 62 (K01 / K52)		
78H-243-7102N	A10VSO 71 RIGHT HAND REAR COVER / THRU - DRIVE 4" 2 BOLT SAE SIDE PORT 62 (K04 / K68)		
78H-243-7103N	A10VSO 71 LEFT HAND REAR COVER / THRU - DRIVE 4" 2 BOLT SAE SIDE PORT 62 (K04 / K68)		
78H-243-7102G	A10VSO 71 RIGHT HAND REAR COVER / THRU - DRIVE 5" 2 BOLT SAE SIDE PORT 62 (K07)		
78H-243-7103G	A10VSO 71 LEFT HAND REAR COVER / THRU - DRIVE 5" 2 BOLT SAE SIDE PORT 62 (K07)		
78H-243-3601	A10VSO 71 BILLET ADAPTOR 9 SPLINE K01		
78H-243-3601E	A10VSO 71 BILLET ADAPTOR 11 SPLINE K52		
78H-243-3601B	A10VSO 71 BILLET ADAPTOR 13 SPLINE K02 / K68		
78H-243-3601C	A10VSO 71 BILLET ADAPTOR 32mm PARALLEL KEY		
78H-243-3601A	A10VSO 71 BILLET ADAPTOR 14 SPLINE K07		
78H-243-3601D	A10VSO 71 BILLET ADAPTOR 15 SPLINE K04		
78H-243-3101K	A10VSO 71 SHAFT 1-1/4" P / KEY TYPE K		
78H-243-3101D	A10VSO 71 SHAFT 1-1/4" P / THRU - DRIVE TYPE K		
78H-243-3201S	A10VSO 71 SHAFT 14 SPLINE TYPE S		
78H-243-3201A	A10VSO 71 SHAFT 14 SPLINE / THRU - DRIVE TYPE S		
78H-240-7300	A10VSO 71 CONTROL VALVE DR		
78H-240-7200	A10VSO 71 CONTROL VALVE DFR		
78H-240-7400	A10VSO 71 CONTROL VALVE DFR1		
78H-240-72-DRG	A10VSO 71 CONTROL VALVE DRG		
78H-242-7800	A10VSO 71 HORSE POWER CONTROLLER 22Kw		
78H-243-7110	A10VSO 71 CONTROL PISTON ASSEMBLY		
78H-243-7120	A10VSO 71 COUNTER PISTON ASSEMBLY		
78H-243-7135	A10VSO 71 BIAS SPRING		
78H-243-7630A	A10VSO 18 ~ 100 0.8 ORIFICE DFR ADAPTER		
78H-243-SL-M6	A10VSO 18 ~ 100 DOUBLE HEAD PLUG SL-M6 A6VM160		
78H-243-B6X18	A10VSO 18 ~ 100 COLUMN PIN B6x18 GB/T119		



Part Number	<b>PUMPS PISTON</b>		RETAIL:	
	<a href="#">A 10V 31 SERIES PISTON PUMP</a>		01-10-2022	
	<a href="#">A10VSO 100 SPARES</a>			
78H-244-3306C	A10VSO 100 SEAL KIT			
78H-A10V100-ROT	A10VSO 100 ROTATING GROUP ASSEMBLY 100cc			
78H-244-1101	A10VSO 100 CYLINDER BLOCK			
78H-244-2100C	A10VSO 100 PISTON			
78H-244-1201	A10VSO 100 BARREL WASHER			
78H-244-1301	A10VSO 100 COIL SPRING			
78H-244-1401	A10VSO 100 PRESS PIN			
78H-244-1501	A10VSO 100 SNAP RING			
78H-244-4102F	A10VSO 100 BALL GUIDE			
78H-244-4111	A10VSO 100 RETAINER PLATE			
78H-244-7103	A10VSO 100 HEAD BLOCK LEFT HAND METRIC			
78H-244-7102	A10VSO 100 HEAD BLOCK RIGHT HAND METRIC			
78H-244-3704	A10VSO 100 SHAFT BIG BEARING FRONT			
78H-244-3704A	A10VSO 100 SHAFT SMALL BEARING REAR			
78H-244-4401	A10VSO 100 VALVE PLATE RIGHT HAND			
78H-244-4501	A10VSO 100 VALVE PLATE LEFT HAND			
78H-244-5220	A10VSO 100 SWASH PLATE RIGHT HAND			
78H-244-5320	A10VSO 100 SWASH PLATE LEFT HAND			
78H-244-5251	A10VSO 100 SADDLE BEARING			
78H-244-7102B	A10VSO 100 HEAD BLOCK RIGHT HAND SAE SINGLE SIDE PORT 62 N00			
78H-244-7103B	A10VSO 100 HEAD BLOCK LEFT HAND SAE SINGLE SIDE PORT 62 N00			
78H-244-7102N	A10VSO 100 RIGHT HAND REAR COVER / THRU - DRIVE 4" 2 BOLT SAE SIDE PORT 62 (K04 / K68)			
78H-244-7102C	A10VSO 100 RIGHT HAND REAR COVER / THRU - DRIVE 5" 2 BOLT SAE SIDE PORT 62 (K07)			
78H-244-7103C	A10VSO 100 LEFT HAND REAR COVER / THRU - DRIVE 5" 2 BOLT SAE SIDE PORT 62 (K07)			
78H-244-3601	A10VSO 100 BILLET ADAPTOR 9 SPLINE K01			
78H-244-3601B	A10VSO 100 BILLET ADAPTOR 13 SPLINE K02 / K68			
78H-244-3601A	A10VSO 100 BILLET ADAPTOR 14 SPLINE K07			
78H-244-3601C	A10VSO 100 BILLET ADAPTOR 15 SPLINE K04			
78H-244-3101K	A10VSO 100 SHAFT 1-1/2" P / KEY TYPE K			
78H-244-3101D	A10VSO 100 SHAFT 1-1/2" P / THRU - DRIVE TYPE K			
78H-244-3201B	A10VSO 100 SHAFT 14 SPLINE TYPE U			
78H-244-3201D	A10VSO 100 SHAFT 14 SPLINE/THRU/D TYPE U			
78H-244-3201S	A10VSO 100 SHAFT 17 SPLINE TYPE S			
78H-244-3201	A10VSO 100 SHAFT 17 SPLINE / THRU - DRIVE TYPE S			
78H-240-7300	A10VSO 100 CONTROL VALVE DR			
78H-240-7200	A10VSO 100 CONTROL VALVE DFR			
78H-240-7400	A10VSO 100 CONTROL VALVE DFR1			
78H-240-72-DRG	A10VSO 100 CONTROL VALVE DRG			
78H-242-7800	A10VSO100 HORSE POWER CONTROLLER 30Kw			
78H-244-7110A	A10VSO 100 CONTROL PISTON ASSEMBLY			
78H-244-7120	A10VSO 100 COUNTER PISTON ASSEMBLY			
78H-244-7135	A10VSO 100 BIAS SPRING			
78H-244-7630A	A10VSO 18 ~ 100 0.8 ORIFICE DFR ADAPTER			
78H-244-SL-M6	A10VSO 18 ~ 100 DOUBLE HEAD PLUG SL-M6 A6VM160			
78H-244-B6X18	A10VSO 18 ~ 100 COLUMN PIN B6x18 GB/T119			



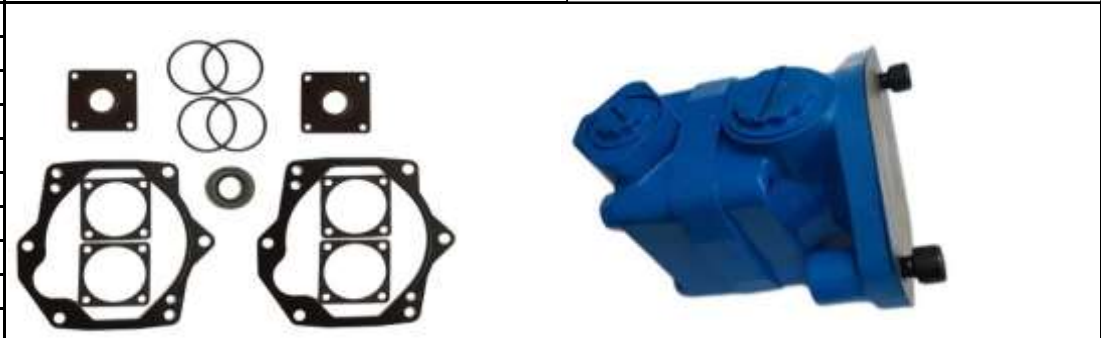

PART NUMBER	PUMPS PISTON		RETAIL	
			01-10-2022	
	<u>TA 19/19 SERIES CLOSE LOOP PISTON PUMP 350 Bar</u>			
	<u>COMPLETE PUMP</u>			
78H-TA19/19V20	TA19/19V20R2BR09CC21557			
	<u>TA19/19 SPARES</u>			
78H-678-3306	COMPLETE SEAL KIT SEAL			
78H-FOB-0085	DRIVE SHAFT SEAL 25.4 X 44.5 X 7.95			
78H-678-3201	DRIVE SHAFT FRONT			
78H-678-3202	DRIVE SHAFT REAR			
78H-678-7804	CONNECTING SLEEVE			
78H-752-5221	DRIVE SHAFT BEARING BIG FRONT			
78H-759-1100	DRIVE SHAFT BEARING SMALL BACK			
78H-759-2100	ROTATING GROUP COMPLETE WITH PISTONS			
78H-679-2100	PISTON			
78H-678-4401	VALVE PLATE R			
78H-678-4501	VALVE PLATE L			
78H-678-6101	HOUSING ALUMINUM			
78H-678-7156	HOUSING GASKET			
78H-678-7101	VALVE BLOCK CENTRE BODY			
78H-678-7200A	VALVE BLOCK PORT RELIEF VALVES			
78H-678-7301	REPLENISHING RELIEF VALVE			
78H-678-5221	YOKE SWASH PLATE			
78H-679-3704B	YOKE SWASH BEARING			
78H-678-6131	YOKE SWASH COVER			
78H-678-6130	YOKE SWASH COVER WITH SEAL			
78H-Y679-6132	YOKE SWASH COVER GASKET SHIM SET			
78H-V20-19-19	V20 COMPLETE PUMP			
78H-678-7804A	V20 CONNECTING SLEEVE			
78H-V20-9	V20 CAM RING 9 GAL			
78H-V20-1	V20 INLET BODY			
78H-V20-2	V20 PRESSURE PLATE			
78H-V20-3	V20 DRIVE SHAFT			
				
				

PLEASE NOTE: ALL O.E.M. NAMES OR NUMBERS ARE FOR REFERENCE USE ONLY



<b><u>BMR - SERIES</u></b>							
COMPETITOR MODELS ; ( OMR - DANFOSS ) ( BMR - ZHENJIANG ) ( S - CHAR - LYNN )							
Specs ; 25mm P/KEY SHAFT 3-1/4" SPIGOT 2 BOLT MOUNT & 1" SHAFT ON REQUEST							
	Type cc/rev	Cont. Speed	Cont. flow	Cont. Press Drop	Cont. Torque	Cont. Kw	Rotor Height
79H-BMR-36P1	BMR 36	800 rpm	40 L	140 bar	70 Nm	7	8.0 mm
79H-BMR-50P1	BMR 50	775 rpm	60 L	140 bar	93 Nm	7	9.0 mm
79H-BMR-80P1	BMR 80	750 rpm	60 L	140 bar	152 Nm	10	14 mm
79H-BMR-100P1	BMR 100	475 rpm	60 L	140 bar	194 Nm	10	17.5 mm
79H-BMR-125P1	BMR 125	600 rpm	60 L	140 bar	237 Nm	10	22 mm
79H-BMR-160P1	BMR 160	470 rpm	60 L	140 bar	310 Nm	10	28 mm
79H-BMR-200P1	BMR 200	300 rpm	60 L	140 bar	369Nm	8	35 mm
79H-BMR-250P1	BMR 250	240 rpm	60 L	110 bar	380 Nm	6	44 mm
79H-BMR-315P1	BMR 315	190 rpm	60 L	90 bar	380 Nm	5	56 mm
79H-BMR-400P1	BMR 400	160 rpm	60 L	70 bar	380 Nm	4	70 mm

<b><u>BMR - SERIES</u></b>							
COMPETITOR MODELS ; ( OMR - DANFOSS ) ( BMR - ZHENJIANG ) ( S - CHAR - LYNN )							
Specs ; 1" P/KEY SHAFT 1-3/4" SPIGOT 4 BOLT SQUARE MOUNT							
	Type cc/rev	Cont. Speed	Cont. flow	Cont. Press Drop	Cont. Torque	Cont. Kw	Rotor Height
79H-BMR-36P3	BMR 36	800 rpm	40 L	140 bar	70 Nm	7	8.0 mm
79H-BMR-50P3	BMR 50	775 rpm	60 L	140 bar	93 Nm	7	9.0 mm
79H-BMR-80P3	BMR 80	750 rpm	60 L	140 bar	152 Nm	10	14 mm
79H-BMR-100P3	BMR 100	475 rpm	60 L	140 bar	194 Nm	10	17.5 mm
79H-BMR-125P3	BMR 125	600 rpm	60 L	140 bar	237 Nm	10	22 mm
79H-BMR-160P3	BMR 160	470 rpm	60 L	140 bar	310 Nm	10	28 mm
79H-BMR-200P3	BMR 200	300 rpm	60 L	140 bar	369Nm	8	35 mm
79H-BMR-250P3	BMR 250	240 rpm	60 L	110 bar	380 Nm	6	44 mm
79H-BMR-315P3	BMR 315	190 rpm	60 L	90 bar	380 Nm	5	56 mm
79H-BMR-400P3	BMR 400	160 rpm	60 L	70 bar	380 Nm	4	70 mm

63H-V05900500	VALVE VAU DE C 1/2" OMP / OMR CROSS OVER PORT RELIEF MOTOR
79H-BMRXX-H2	4 BOLT MOUNT 6 SPLINE USE BMR-XXP1 A11Y10/T7 PRICE AND ADD
79H-BMRSKAIT7	BMR SEAL KIT T7 FOR P1 / P3 BMR/SK/AII/T7 ID: 30 OD: 48 W: 7 3-1/4" SPIGOT 2 BOLT MOUNT
79H-BMRSKC1T10	BMR SEAL KIT T10 FOR P3 BMR/SK/C1/T10 ID: 28 OD: 42 W: 5 1-3/4" SPIGOT 4 BOLT MOUNT

<b><u>BMR - SERIES MOTOR DATA</u></b>							
	TYPE	SPIGOT	MOUNT	SHAFT	KEY WIDTH	PORTS	DRAIN
79H-BMRXX-P1	BMR - SERIES	3-1/4"	2 BOLT	25mm P/K	8mm	1/2"BSPP	1/4"BSPP
79H-BMRXX-P52	BMR - SERIES	3-1/4"	2 BOLT	32mm P/K	8mm	1/2"BSPP	1/4"BSPP
79H-BMRXX-P3	BMR - SERIES	1-3/4"	4 BOLT	1" P/K	6,35mm	1/2"BSPP	1/4"BSPP
79H-BMRXX-H2	BMR - SERIES	1-3/4"	4 BOLT	6 SPLINE	25 mm O/D	1/2"BSPP	1/4"BSPP



BMR-XXXXP3



BMR-XXXXP1



VAU 1/2" BMR

Part Number	<b>MOTORS GEROLOR TAK - BOK</b>							RETAIL: 01-10-2022
<b><u>BM3Y - SERIES</u></b>								
COMPETITOR MODELS ; ( OMS - DANFOSS ) ( BMS - ZHENJIANG ) ( 2000 - CHAR - LYNN )								
Specs ; 1-1/4" P/KEY SHAFT 3-1/4" SPIGOT 4 BOLT MAGNETO MOUNT								
	<u>Type</u>	<u>cc/rev</u>	<u>Cont. Speed</u>	<u>Cont. Flow</u>	<u>Cont. Press Drop</u>	<u>Cont. Torque</u>	<u>Cont. Kw</u>	<u>Rotor Height</u>
79H-BM3Y-100P5	BM3Y	100	750 rpm	75 L	175 bar	283 Nm	16	14.5 mm
79H-BM3Y-125P5	BM3Y	125	600 rpm	75 L	175 bar	345 Nm	16	19 mm
79H-BM3Y-160P5	BM3Y	160	470 rpm	75 L	160 bar	429 Nm	16	25 mm
79H-BM3Y-200P5	BM3Y	200	375 rpm	75 L	160 bar	540 Nm	14	32 mm
79H-BM3Y-250P5	BM3Y	250	300 rpm	75 L	125 bar	580 Nm	11	41 mm
79H-BM3Y-315P5	BM3Y	315	240 rpm	75 L	125 bar	625 Nm	10	53 mm
79H-BM3Y-400P5	BM3Y	400	180 rpm	75 L	100 bar	687 Nm	08	67 mm
79H-BM3-K3SH	BM3 K3 SHAFT 1-1/4" 14 SPLINE ADD ON TO PRICE - LENGTH 56,5mm							
79H-BM3Y-K13SH	BM3Y K13 SHAFT 1-1/4" 14 SPLINE ADD ON TO PRICE - LENGTH 63,5mm (Zhenjiang)							
79H-BM3SK	BMS SEAL KIT							
<b><u>BM4U - SERIES</u></b>								
COMPETITOR MODELS ; ( OMT - DANFOSS ) ( BMT - ZHENJIANG ) ( 4000 - CHAR - LYNN )								
Specs ; 40mm SHAFT 125 SPIGOT 4 BOLT SQUARE MOUNT								
	<u>Type</u>	<u>cc/rev</u>	<u>Cont. Speed</u>	<u>Cont. Flow</u>	<u>Cont. Press Drop</u>	<u>Cont. Torque</u>	<u>Cont. Kw</u>	<u>Rotor Height</u>
79H-BM4U-200P3	BM4U	200	625 rpm	125 L	200 Bar	714 Nm	25	16.5 mm
79H-BM4U-250P3	BM4U	250	500 rpm	125 L	200 Bar	883 Nm	25	22.0 mm
79H-BM4U-320P3	BM4U	320	380 rpm	125 L	200 Bar	1143 Nm	25	29.0 mm
79H-BM4U-400P3	BM4U	400	305 rpm	125 L	180 Bar	1095 Nm	22	38.0 mm
79H-BM4U-500P3	BM4U	500	240 rpm	125 L	160 Bar	1377 Nm	31	56.0 mm
79H-BM4U-600P3	BM4U	600	196 rpm	125 L	140 Bar	1318 Nm	25.3	54.0 mm
79H-BM4U-725P3	BM4U	725	154 rpm	125 L	125 Bar	1464 Nm	22.2	73.5 mm
<b><u>BM4E - SERIES</u></b>								
COMPETITOR MODELS ; ( OMT-DANFOSS ) ( BMT - ZHENJIANG ) ( 4000 - CHAR-LYNN )								
Specs ; 1-1/4" P/KEY SHAFT 4" SPIGOT 4 BOLT SQUARE MOUNT								
	<u>Type</u>	<u>cc/rev</u>	<u>Cont. Speed</u>	<u>Cont. Flow</u>	<u>Cont. Press Drop</u>	<u>Cont. Torque</u>	<u>Cont. Kw</u>	<u>Rotor Height</u>
79H-BM4E-200P13	BM4E	200	625 rpm	125 L	200 Bar	714 Nm	25	16.5 mm
79H-BM4E-250P13	BM4E	250	500 rpm	125 L	200 Bar	883 Nm	25	22.0 mm
79H-BM4E-320P13	BM4E	320	380 rpm	125 L	200 Bar	1143 Nm	25	29.0 mm
79H-BM4E-400P13	BM4E	400	305 rpm	125 L	180 Bar	1095 Nm	22	38.0 mm
79H-BM4E-500P13	BM4E	500	240 rpm	125 L	160 Bar	1377 Nm	31	56.5 mm
<b><u>BM3 &amp; BM4 - SERIES MOTOR DATA</u></b>								
	TYPE	SPIGOT	MOUNT	SHAFT	KEY WIDTH	PORTS	DRAIN	
79H-BM3XX-P5	BM3 - SERIES	3-1/4"	4 Magneto	1-1/4" P/K	7,96mm	1/2"BSPP	1/4"BSPP	
79H-BM3XX-K13	BM3 - SERIES	3-1/4"	4 Magneto	14 SPLINE	1-1/4" O/D	1/2"BSPP	1/4"BSPP	
79H-BM4UXX-P3	BM4U - SERIES	125mm	4 BOLT	40mm P/K	12mm	3/4"BSPP	1/4"BSPP	
79H-BM4EXX-P13	BM4E - SERIES	4"	4 BOLT	1-1/4" P/K	7,96mm	3/4"SAE"0"	3/8"SAE"0"	
79H-BM4EXX-K10	BM4E - SERIES	4"	4 BOLT	14 SPLINE	1-1/4" O/D	3/4"SAE"0"	3/8"SAE"0"	
79H-BM4U-SK	BM4U SEAL KIT							
								
	BM3-XXX3			BM4-XXP3				
PLEASE NOTE: ALL O.E.M. NAMES OR NUMBERS ARE FOR REFERENCE USE ONLY								
							PAGE T 2	

Part Number	<b>MOTORS GEROLOR TAK - BOK</b>							RETAIL:
								01-10-2022
	<b><u>BM5 - SERIES</u></b>							
	COMPETITOR MODELS; ( OMV - DANFOSS ) ( BMV - ZHENJIANG ) ( 10 000 - CHAR-LYNN )							
	Specs ; 2-1/4" P/KEY SHAFT 5" SPIGOT 4 BOLT MOUNT							
	Type	cc/rev	Cont. Speed	Cont. flow	Cont. Press Drop	Cont. Torque	Cont. Kw	Rotor Height
79H-BM5U315P10	BM5U 315		10-475 rpm	150 litres	200 bar	873 Nm	32	19 mm
79H-BM5U400P10	BM5U 400		9-375 rpm	150 litres	200 bar	1108 Nm	32	26 mm
79H-BM5U500P10	BM5U 500		8-300 rpm	150 litres	200 bar	1385 Nm	32	34 mm
79H-BM5U630P10	BM5U 630		6-315 rpm	150 litres	200 bar	1570 Nm	40	44 mm
	<b><u>BM5 - SERIES MOTOR DATA</u></b>							
	TYPE	SPIGOT	MOUNT	SHAFT	KEY WIDTH	PORTS	DRAIN	
79H-BM5UXX-P10	BM5U - SERIES	5"	4 BOLT	2-1/4" P/K	12,7mm	1" SAE "O"	3/8" SAE "O"	
79H-BM5U-SK	BM5 SEAL KIT							
	<b><u>TKRE - SERIES</u></b>							
	COMPETITOR MODELS; ( TKRE-TAK-BOK ) ( BMRE - ZHENJIANG ) ( TG - PARKER ) ( RE - 5001 WHITE )							
	SPECS ; 1-1/4" P/K SHAFT 3-1/4" SPIGOT 4 BOLT MAGNETO MOUNT NO CASE DRAIN							
	Type	cc/rev	Cont. Speed	Cont. flow	Cont. Press Drop	Cont. Torque	Cont. Kw	Rotor Height
79H-TKRE-125G2	TKRE 125		360 rpm	60 litres	205 bar	325 Nm	12	10.2 mm
79H-TKRE-160G2	TKRE 160		375 rpm	60 litres	205 bar	450 Nm	15	13.5 mm
79H-TKRE-200G2	TKRE 200		330 rpm	60 litres	205 bar	530 Nm	15.5	17.0 mm
79H-TKRE-230G2	TKRE 230		290 rpm	60 litres	205 bar	625 Nm	16	19.5 mm
79H-TKRE-250G2	TKRE 250		290 rpm	60 litres	205 bar	700 Nm	17.5	22.0 mm
79H-TKRE-300G2	TKRE 300		250 rpm	60 litres	205 bar	810 Nm	18	25.4 mm
79H-TKRE-350G2	TKRE 350		220 rpm	60 litres	205 bar	905 Nm	17.5	29.4 mm
79H-TKRE-375G2	TKRE 375		200 rpm	60 litres	205 bar	990 Nm	16.5	31.8 mm
79H-TKRE-475G2	TKRE 475		160 rpm	60 litres	175 bar	1085 Nm	14.5	39.4 mm
79H-TKRE-540G2	TKRE 540		140 rpm	60 litres	140 bar	980 Nm	11.5	47.3 mm
79H-TKRE-750G2	TKRE 750		100 rpm	60 litres	105 bar	1050 Nm	8	63.5 mm
79H-TKRE-S-KIT	TKRE SEAL KIT							
79H-TKRE-B-KIT	TKRE BEARING KIT							
	<b><u>TKRE - SERIES MOTOR DATA</u></b>							
	TYPE	SPIGOT	MOUNT	SHAFT	KEY WIDTH	PORTS	DRAIN	
79H-TKREXXG2	TKRE -SERIES	3-1/4"	4 BOLT	1-1/4" P/K		1/2"BSPP	NONE	
79H-TKREXXRW	TKRE -SERIES	3-1/4"	4 BOLT	1" P/K		1/2"BSPP	NONE	
79H-TKREXXFD1	TKRE -SERIES	3-1/4"	4 BOLT	14 SPLINE		1/2"BSPP	NONE	
	<b><u>USEFUL DATA</u></b>							
	CODE; TKRE 200 = ( 196cc = 12cu.in )				CODE; TKRE 230 = ( 228cc = 14cu.in )			
	CODE; TKRE 250 = ( 257cc = 16cu.in )				CODE; TKRE 300 = ( 296cc = 18cu.in )			
	CODE; TKRE 350 = ( 345cc = 20cu.in )				CODE; TKRE 375 = ( 371cc = 24cu.in )			
	CODE; TKRE 475 = ( 462cc = 26cu.in )				CODE; TKRE 540 = ( 540cc = 32cu.in )			
	CODE; TKRE 750 = ( 745cc = 48cu.in )							

BM5U-XXXP10



TKRE-XXXG2





<b><u>BMM - SERIES</u></b>							
COMPETITOR MODELS ; ( OMM - DANFOSS ) ( BMM - ZHENJIANG ) ( J - CHAR-LYNN )							
Specs ; 16mm P/KEY SHAFT 3-1/4" 2 BOLT FLANGE 63mm SPIGOT REAR PORTS							
	<u>Type cc/rev</u>	<u>Cont. Speed</u>	<u>Cont. flow</u>	<u>Cont. Press Drop</u>	<u>Cont. Torque</u>	<u>Cont. Kw</u>	<u>Rotor Height</u>
79H-BMM-08P1Y	BMM 08	1950 rpm	16 L	100 bar	16 Nm	1.8	3.5 mm
79H-BMM-12P1Y	BMM 12	1550 rpm	20 L	100 bar	16 Nm	2.4	5.5 mm
79H-BMM-20P1Y	BMM 20	1000 rpm	20 L	100 bar	25 Nm	2.4	8.5 mm
79H-BMM-32P1Y	BMM 32	630 rpm	20 L	100 bar	40 Nm	2.4	13.5 mm
79H-BMM-40P1Y	BMM 40	500 rpm	20 L	90 bar	45 Nm	2.2	17.0 mm
79H-BMM-50P1Y	BMM 50	400 rpm	20 L	70 bar	46 Nm	1.8	21.5 mm

<b><u>BMM - SERIES MOTOR DATA</u></b>							
	<u>TYPE</u>	<u>SPIGOT</u>	<u>MOUNT</u>	<u>SHAFT</u>	<u>KEY WIDTH</u>	<u>PORTS</u>	<u>DRAIN</u>
79H-BMM-XXP1Y	BMM - SERIES	3-1/4" ( 63mm)	2 BOLT	16mm P/K	5mm	3/8"BSPP REAR	1/8" BSPP
79H-BMM-XXP1S	BMM - SERIES	3-1/4" ( 63mm)	2 BOLT	16mm P/K	5mm	3/8"BSPP SIDE	1/8" BSPP
79H-BMM-XXK1Y	BMM - SERIES	3-1/4" ( 63mm)	2 BOLT	9 SPLINE		3/8"BSPP REAR	1/8" BSPP
79H-BMM-XXK1S	BMM - SERIES	3-1/4" ( 63mm)	2 BOLT	9 SPLINE		3/8"BSPP SIDE	1/8" BSPP

<b><u>JMGD - SERIES</u></b>							
COMPETITOR MODELS ;							
Specs ; 38mm P/KEY SHAFT 190mm SPIGOT 5 BOLT FLANGE SIDE PORTS							
	<u>Type cc/rev</u>	<u>Speed</u>	<u>Cont. flow</u>	<u>Cont. Press Drop</u>	<u>Cont. Torque</u>	<u>Cont. Kw</u>	
79H-JMDG3-300B	JMGB 289	30-350 rpm	105 L	140 bar	720 Nm	32	

<b><u>JMGD- SERIES MOTOR DATA</u></b>							
	<u>TYPE</u>	<u>SPIGOT</u>	<u>MOUNT</u>	<u>SHAFT</u>	<u>KEY WIDTH</u>	<u>PORTS</u>	<u>DRAIN</u>
79H-JMDG3-XXB	JMGD - SERIES	190mm	5 BOLT	38mm P/K	10mm	3/4"BSPP SIDE	3/8" BSPP





**A2FM - SERIES**

**Specs ; 20mm P/KEY SHAFT 4 BOLT FLANGE 80mm SPIGOT REAR & SIDE PORTS**  
**Type cc/rev Cont. Speed Cont. flow Cont. Press Drop Cont. Torque Cont. Kw Rotor Height**

79H-A2FM12	A2FM 12
79H-A2FM16	A2FM 16
79H-A2FM23	A2FM 23





<b>SHAFT ONLY</b>					
79H-BMR-SH-P1	BMR SHAFT P1 / T10 - 25 mm PARALLEL KEY, 8 x 7 x 32 (HIRSCH POPULAR ONE).				
79H-BMR-SH-P3	BMR SHAFT P3 - 25.4 mm PARALLEL KEY SHAFT IMPERIAL ONLY 6.35 x 6.35 x 32				
79H-BMR-SH-P52	BMR SHAFT P52 - 32 mm P/KEY, 10x8x45 (3mm LONGER THAN P5 SHAFT) REPLACES P5 SHAFT				
79H-BMR-SH-H3	BMR SHAFT H3 - 25.4 mm 6 SPLINED SHAFT IMPERIAL, 6-25.4 x 21.4 x 6.2				
79H-BM3-SH-P5	BM3 SHAFT 1-1/4" P/KEY TYPE FOR 80cc & 100cc WITH NUT (40mm OD BEARING) M36 x 1.5 THREAD				
79H-BM3-SH-K10	BM3 14 TOOTH SPLINED SHAFT FOR 80cc & 100cc WITH NUT (40mm OD BEARING) M40 x 1.5 THREAD				
79H-BM3-SH-K3	SPECIAL - BM3 SPLINED SHAFT 1-1/4" 14 TEETH FOR 80cc & 100cc WITH NUT (40mm OD BEARING)				
79H-BM3Y-SH-P5	BM3Y SHAFT 1-1/4" P/KEY FOR 125cc - 500cc WITH NUT (45mm OD BEARING) M42 x 1.5 THREAD				
79H-BM3Y-SH-K3	BM3Y SPLINED SHAFT 1-1/4" 14 TEETH FOR 125cc - 500cc WITH NUT (45mm OD) M42 x 1.5 THREAD				
79H-BM3Y-SH-K13	SPECIAL - BM3Y SPLINED SHAFT 1-1/4" 14 TEETH FOR 125cc - 500cc (BM3Y K13) WITH NUT (45mm OD)				

<b>KEY ONLY</b>					
79H-BMM-KEY-P1	BMM SHAFT KEY P1 5 X 5 X 16				
79H-BMR-KEY-P1	BMR SHAFT KEY P1 8 X 7 X 32				
79H-BMR-KEY-P3	BMR SHAFT KEY P3 6.35 X 6.35 X 32				
79H-BMR-KEY-P5	BMR SHAFT KEY P5 10 x 8 x 45				
79H-BMR-KEY-P52	BMR SHAFT KEY P52 10 x 8 x 45				
79H-BM3Y-KEY-P5	BM3Y SHAFT KEY P5 7.96 X 7.96 X 32				
79H-BM4U-KEY-P3	BM4U SHAFT KEY P3 12 X 8 X 70				
79H-BM4EKEY-P13	BM4E SHAFT KEY P13 7.96 X 7.96 X 36 (changed IT WAS 7.96 X 7.96 X 38)				
79H-BM5UKEY-P10	BM5U SHAFT KEY P10 12.7 X 12.7 X 57				

<b>BEARING SET</b>					
79H-BMM-SB-P1	BEARING SET BMM-31*17*7 = QTY/set x 1				
79H-BMR-SB-P1	BEARING BMR-30*62*16(C2) + RETAINER RING A-30*1.2				
79H-BMR-SB-P3	BEARING BMR-30*62*16(C2) + RETAINER RING A-30*1.2				
79H-BMR-SB-H3	BEARING BMR-30*62*16(C2) + RETAINER RING A-30*1.2				
79H-BMR-SB-P5	BEARING BMR-35*62*14 + RETAINER RING A-35*1.5				
79H-BMR-SB-P52	BEARING BMR-35*62*14 + RETAINER RING A-35*1.5				
79H-BM3-SB-K10	Bearing BM3-40*68*19X2 + Lock nut BMRW1-11 + Space ring BM3-21				
79H-BM3-SB-K3	Bearing BM3-40*68*19X2 + Lock nut BMRW1-11 + Space ring BM3-21				
79H-BM3-SB-P5	Bearing BM3-40*68*19X2 + Lock nut BMRW1-11 + Space ring BM3-21				
79H-BM3Y-SB-P5	Bearing BM3Y-45*68*15X2 + Lock nut BM3Y-17 + Space ring BM3Y-21				
79H-BM3Y-SB-K3	Bearing BM3Y-45*68*15X2 + Lock nut BM3Y-17 + Space ring BM3Y-21				
79H-BM3Y-SB-K13	Bearing BM3Y-45*68*15X2 + Lock nut BM3Y-17 + Space ring BM3Y-21				
79H-BM4U-SB-P3	Bearing BM4-55*90*23X2 + Lock nut BM4020 + Space ring BM4021				
79H-BM4E-SB-P13	Bearing BM4-55*90*23X2 + Lock nut BM4020 + Space ring BM4021				
79H-BM5U-SB-P10	Bearing BM5-65*100*23X2 + Lock nut BM5020 + Space ring BM5021				



Part Number	<b>WINCHES</b>												RETAIL:
													<b>01-10-2022</b>
	The Hydraulic Winch consists of a BM Hydraulic Motor, a planetary Gear Box decelerator, a mechanical wet brake, spring assist, hydraulic release, 2 over centre valves and 2 cross over port relief valves.												
	It should be noted that when sizing a winch, not only the line pull should be taken into consideration, but also the maximum rope speed in metres per minute. Refer to data sheet												
	<b><u>HYDRAULIC WINCH</u></b>												
84H-YJ10-1T125	1 TON WINCH INLET FLOW 35 LITERS PRESSURE SET TO 128 Bar BM3-125 1/2" BSPP PORTS												
84H-YJ10-1T200	1 TON WINCH INLET FLOW 75 LITERS PRESSURE SET TO 80 Bar BM3-200 3/4" BSPP PORTS												
84H-YJ20-2T320	2 TON WINCH INLET FLOW 90 LITERS PRESSURE SET TO 120 BAR BM4-320 3/4" BSPP PORTS												
	<b><u>WINCH SPARES</u></b>												
84H-K5-BM3	OVERCENTRE VALVE BLOCK FOR 1 TON WINCH												
84H-K5-BM4	OVERCENTRE VALVE BLOCK FOR 2 TON WINCH												
84H-YJ10-BM3	MOTOR TO FIT YJ10												
84H-YJ20-BM4	MOTOR TO FIT -YJ20												
	<b><u>WINCH- SERIES MOTOR DATA</u></b>												
		MAX	MAX							Max Rope			
		PULL	PULL	Working	Rope	Rope	Rope			Speed		Associated	
	TYPE	FIRST	LAST	Pressure	Layers	Diameter	Capacity	Disp.	Flow	Firstn	Lastn	Motor	Weight
		kg	kg	Mpa	n	mm	m	cc/r	Liters	m/min	m/min		kg
	YJ10	1000	800	128	4	8	53	625	35	36	41	BM3-125	46
	YJ10	1000	800	80	4	8	53	1000	75	36	41	BM3-200	46
	YJ20	2000	1650	120	4	12	50	1600	90	30	36	BM4-320	103
	<b><u>WINCH DIMENSIONS</u></b>												
	YJ10 ; WIDTH 371mm , SIDE 280mm , HEIGHT 286mm , DRUM OD 168mm, Drum Circ 527mm												
	YJ20 ; WIDTH 423mm , SIDE 370mm , HEIGHT 392mm , DRUM OD 216mm, Drum Circ 678mm												
	<b><u>LINE SPEED CALCULATIONS</u></b>												
	MODEL YJ20-2000 ; DRUM DIAMETER 216mm X 3.14 = 678mm DRUM CIRCUMFERENCE ÷ LINE SPEED OF 30 METERS PER MIN = 44.25 DRUM RPM												
	THEREFORE 44.5 DRUM RPM X 5 GEAR BOX RATIO = 221.25 RPM X MOTOR 320c/r = 70.1 INPUT LITERS												
	<p>YJ-20 HYDRAULIC WINCH</p>  <p>YJ-10 HYDRAULIC WINCH</p> 												
	<b>PLEASE NOTE: ALL O.E.M. NAMES OR NUMBERS ARE FOR REFERENCE USE ONLY</b>												<b>PAGE T 7</b>

<u>Part Number</u>	<b>STEERING UNITS</b>					<b>RETAIL:</b>
						<b>15-02-2023</b>
	<b><u>BPBSI - HKUS / 4 SERIES</u></b>					
	OPEN CENTRE NON LOAD REACTIVE					
	RELIEF VALVE ON P PORT (150 Bar)					
	COMPETITOR MODELS ; DANFOSS ( OSPC***ON ; OSPB***ON ) M&S ( HKUS***/4 ; HKU***/4 )					
	<b><u>HKUS / 4 SERIES</u></b>	<b><u>DISPLACEMENT</u></b>	<b><u>MAX INPUT</u></b>	<b><u>MAIN PRESSURE SET</u></b>	<b><u>ROTOR HEIGHT</u></b>	
80H-BPBS1-50	HKUS 50 / 4 / A	49.5cc per rev	6 LPM	150 bar	6.6 mm	
80H-BPBS1-63	HKUS 63 / 4 / A	65.5cc per rev	6 LPM	150 bar	9.7 mm	
80H-BPBS1-80	HKUS 80 / 4 / A	79.2cc per rev	9 LPM	150 bar	10.5 mm	
80H-BPBS1-100	HKUS 100 / 4 / A	99.0cc per rev	9 LPM	150 bar	13.0 mm	
80H-BPBS1-125	HKUS 125 / 4 / A	123.8cc per rev	12 LPM	150 bar	16.0 mm	
80H-BPBS1-160	HKUS 160 / 4 / A	158.4cc per rev	12 LPM	150 bar	21.0 mm	
80H-BPBS1-200	HKUS 200 / 4 / A	198.0cc per rev	17 LPM	150 bar	26.0 mm	
80H-BPBS1-250	HKUS 250 / 4 / A	247.5cc per rev	24 LPM	150 bar	32.0 mm	
80H-BPBS1-280	HKUS 280 / 4 / A	280.0cc per rev	28 LPM	150 bar	37.0 mm	
80H-BPBS1-315	HKUS 315 / 4 / A	320.5cc per rev	30 LPM	150 bar	42.0 mm	
80H-BPBS1-400	HKUS 400 / 4 / A	400.5cc per rev	40 LPM	150 bar	52.0 mm	
80H-BPBSEALKIT	HKU SEAL KIT					
	<b><u>STEER WHEEL COLUMN</u></b>					
	<b><u>ACI SERIES</u></b>					
80H-ACI-0075	STEER WHEEL COLUMN LENGTH 75 mm					
80H-ACI-0150	STEER WHEEL COLUMN LENGTH 150 mm					
80H-ACI-0200	STEER WHEEL COLUMN LENGTH 200 mm					
80H-ACI-0400	STEER WHEEL COLUMN LENGTH 400 mm					
80H-ACI-0750	STEER WHEEL COLUMN LENGTH 750 mm					
	<b><u>STEER WHEEL</u></b>					
	<b><u>AV SERIES</u></b>					
80H-AV003200	STEER WHEEL 350 OD mm TO FIT ACI COLUMN					
80H-AT004700	STEER WHEEL CAP					
	<b><u>PORTS:</u></b>					
	P + T 1/2" SAE "O"					
	L + R 1/2" SAE "O"					
	<b><u>MOUNTING THREADS</u></b>					
	MOUNTING TO COLUMN 4 X 3/8 - 16 UNC					
	MOUNTING TO R/V BLOCK 2 X 3/8 - 24 UNF					
	<b><u>POSSIBLE OPTIONS</u></b>					
	HKU NO RELIEF VALVES					
	HKUS RELIEF VALVES BUILT IN					
	4 OPEN CENTER					
	4 A OPEN CENTER					
	5 T CLOSED CENTER LOAD SENSE					
	7 A CLOSED CENTER					
	<b>PLEASE NOTE: ALL O.E.M. NAMES OR NUMBERS ARE FOR REFERENCE USE ONLY</b>					<b>PAGE U 1</b>

<u>Part Number</u>	<b>STEERING UNITS</b>					RETAIL:
						01-10-2022
	<b><u>BPBS5T - HKUS / 5 T SERIES</u></b>					
	CLOSED CENTRE NON LOAD REACTIVE <b>LOAD SENSING</b>					
	RELIEF VALVE ON LS LINE (150Bar) AND SHOCK VALES ON L & R (200Bar)					
	COMPETITOR MODELS ; <b>DANFOSS ( OSPB***LS ) M&amp;S ( HKUS***/5T )</b>					
	<b><u>HKUS / 5 T SERIES</u></b>	<b><u>DISPLACEMENT</u></b>	<b><u>MAX INPUT</u></b>	<b><u>MAIN PRESSURE SET</u></b>	<b><u>ROTOR HEIGHT</u></b>	
80H-BPBS5T-50	HKUS 50 / 5 / T	49.5cc per rev	6 LPM	150 bar	6.6 mm	
80H-BPBS5T-63	HKUS 63 / 5 / T	65.5cc per rev	6 LPM	150 bar	9.7 mm	
80H-BPBS5T-80	HKUS 80 / 5 / T	79.2cc per rev	9 LPM	150 bar	10.5 mm	
80H-BPBS5T-100	HKUS 100 / 5 / T	99.0cc per rev	9 LPM	150 bar	13.0 mm	
80H-BPBS5T-125	HKUS 125 / 5 / T	123.8cc per rev	12 LPM	150 bar	16.0 mm	
80H-BPBS5T-160	HKUS 160 / 5 / T	158.4cc per rev	12 LPM	150 bar	21.0 mm	
80H-BPBS5T-200	HKUS 200 / 5 / T	198.0cc per rev	17 LPM	150 bar	26.0 mm	
80H-BPBS5T-250	HKUS 250 / 5 / T	247.5cc per rev	24 LPM	150 bar	32.0 mm	
80H-BPBS5T-280	HKUS 280 / 5 / T	280.0cc per rev	28 LPM	150 bar	37.0 mm	
80H-BPBS5T-315	HKUS 315 / 5 / T	320.5cc per rev	30 LPM	150 bar	42.0 mm	
80H-BPBS5T-400	HKUS 400 / 5 / T	400.5cc per rev	40 LPM	150 bar	52.0 mm	
80H-BPBS5T-500	HKUS 500 / 5 / T	495.0cc per rev	53 LPM	160 bar	65.0 mm	
80H-BPBS5T-630	HKUS 630 / 5 / T	618.8cc per rev	63 LPM	140 bar	84.0 mm	
80H-BPBS5T-800	HKUS 800 / 5 / T	800.8cc per rev	63 LPM	140 bar	104.0 mm	
80H-BPBSEALKIT	HKU SEAL KIT					
80H-564V115003	BKH 1 MAIN RELIEF + CROSS OVER PORT RELIEFS					
80H-564V300012	BKH 3 PORT RELIEFS ONLY					
	<b><u>BPB3 - HKU / 7 SERIES</u></b>					
	CLOSED CENTRE NON LOAD REACTIVE					
	NO RELIEF ON P SHOCK VALES ON L & R (200Bar)					
	COMPETITOR MODELS ; <b>DANFOSS ( OSPB***CN ) M&amp;S ( HKUS***/7 )</b>					
	<b><u>HKUS / 7 / A SERIES</u></b>	<b><u>DISPLACEMENT</u></b>	<b><u>MAX INPUT</u></b>	<b><u>MAIN PRESSURE SET</u></b>	<b><u>ROTOR HEIGHT</u></b>	
80H-BPB3-50-Y4	HKUS 50 / 7 / A	49.5cc per rev	6 LPM	150 bar	6.6 mm	
80H-BPB3-63-Y4	HKUS 63 / 7 / A	65.5cc per rev	6 LPM	150 bar	9.7 mm	
80H-BPB3-80-Y4	HKUS 80 / 7 / A	79.2cc per rev	9 LPM	150 bar	10.5 mm	
80H-BPB3-100-Y4	HKUS 100 / 7 / A	99.0cc per rev	9 LPM	150 bar	13.0 mm	
80H-BPB3-125-Y4	HKUS 125 / 7 / A	123.8cc per rev	12 LPM	150 bar	16.0 mm	
80H-BPB3-160-Y4	HKUS 160 / 7 / A	158.4cc per rev	12 LPM	150 bar	21.0 mm	
80H-BPB3-200-Y4	HKUS 200 / 7 / A	198.0cc per rev	17 LPM	150 bar	26.0 mm	
80H-BPB3-250-Y4	HKUS 250 / 7 / A	247.5cc per rev	24 LPM	150 bar	32.0 mm	
80H-BPB3-280-Y4	HKUS 280 / 7 / A	280.0cc per rev	28 LPM	150 bar	37.0 mm	
80H-BPB3-315-Y4	HKUS 315 / 7 / A	320.5cc per rev	30 LPM	150 bar	42.0 mm	
80H-BPB3-400-Y4	HKUS 400 / 7 / A	400.5cc per rev	40 LPM	150 bar	52.0 mm	
80H-BPB3-500-Y4	HKUS 500 / 7 / A	495.0cc per rev	53 LPM	160 bar	65.0 mm	
80H-BPB3-630-Y4	HKUS 630 / 7 / A	618.8cc per rev	63 LPM	140 bar	84.0 mm	
80H-BPB3-800-Y4	HKUS 800 / 7 / A	800.8cc per rev	63 LPM	140 bar	104.0 mm	
80H-BPBSEALKIT	HKU SEAL KIT					
	<b><u>PORTS:</u></b>					
	P + T 1/2" SAE "O"					
	L + R 1/2" SAE "O"					
	LS 1/4" SAE "O"					
	<b><u>MOUNTING THREADS</u></b>					
	MOUNTING TO COLUMN 4 X 3/8 - 16 UNC					
	MOUNTING TO R/V BLOCK 2 X 3/8 - 24 UNF					
	<b><u>POSSIBLE OPTIONS</u></b>					
	HKU NO RELIEF VALVES					
	HKUS RELIEF VALVES BUILT IN					
	4 OPEN CENTER					
	4 A OPEN CENTER					
	5 T CLOSED CENTER LOAD SENSE					
	7 A CLOSED CENTER					
						
	<b>PLEASE NOTE: ALL O.E.M. NAMES OR NUMBERS ARE FOR REFERENCE USE ONLY</b>					
						<b>PAGE U 2</b>



# TAK - BOK

## 2" Bore Cylinders

### TIE ROD TYPE



Part Number	Bore x	Rod	Port	Clevis	Barrel	Shaft	Shaft	Barrel	Closed	Open	Force	Force	Swept	Swept	Wt.	RETAIL: 01-10-2022
	Stroke	Dia.	Size	Pin	Bore	stroke	O/D	Length	Centre	Centre	Rod	Piston	Volume	Volume	Kgs	
	inch	inch	Npt	Dia.	mm	mm	mm	mm	mm	mm	180 bar	180 bar	Rod	Piston	+/-	
											Tons	Tons	Litres	Litres		
81H-20006-106	2" x 6"	1-1/16"	3/8"	1"	50.8	152	26.9	210	413	565	2.37	3.53	0.22	0.31	7.1	
81H-20008-106	2" x 8"	1-1/16"	3/8"	1"	50.8	203	26.9	261	464	667	2.37	3.53	0.30	0.41	8	
81H-20008-106A	2" x 8"A	1-1/16"	3/8"	1"	50.8	203	26.9	261	514	717	2.37	3.53	0.30	0.41	8	
81H-20010-106	2" x 10"	1-1/16"	3/8"	1"	50.8	254	26.9	311	514	768	2.37	3.53	0.37	0.51	8.4	
81H-20012-106	2" x 12"	1-1/16"	3/8"	1"	50.8	305	26.9	362	565	870	2.37	3.53	0.44	0.62	9.1	
81H-20014-106	2" x 14"	1-1/16"	3/8"	1"	50.8	356	26.9	413	616	972	2.37	3.53	0.52	0.72	9.8	
81H-20016-106	2" x 16"	1-1/16"	3/8"	1"	50.8	406	26.9	464	667	1073	2.37	3.53	0.59	0.82	10.4	
81H-20018-106	2" x 18"	1-1/16"	3/8"	1"	50.8	457	26.9	515	718	1175	2.37	3.53	0.67	0.93	11.1	
81H-20020-106	2" x 20"	1-1/16"	3/8"	1"	50.8	508	26.9	565	768	1276	2.37	3.53	0.74	1.03	11.7	
81H-20024-106	2" x 24"	1-1/16"	3/8"	1"	50.8	610	26.9	667	870	1480	2.37	3.53	0.89	1.24	13	
81H-20028-106	2" x 28"	1-1/16"	3/8"	1"	50.8	711	26.9	769	972	1683	2.37	3.53	1.04	1.44	14.3	
81H-20030-106	2" x 30"	1-1/16"	3/8"	1"	50.8	762	26.9	819	1022	1784	2.37	3.53	1.11	1.54	15.1	
81H-20036-106	2" x 36"	1-1/16"	3/8"	1"	50.8	914	26.9	972	1175	2089	2.37	3.53	1.33	1.85	17.1	
81H-20048-106	2" x 48"	1-1/6"	3/8"	1"	50.8	1219	26.9	1277	1480	2699	2.37	3.53	1.78	2.47	21.4	
81H-20080-106	2" x 80"	1-1/16"	3/8"	1"	50.8	2032	26.9	2090	2292	4324	2.37	3.53	2.96	4.12	32.5	







# TAK - BOK

## 3" Bore Cylinders

### TIE ROD TYPE



Part Number	Bore x	Rod	Port	Clevis	Barrel	Shaft	Shaft	Barrel	Closed	Open	Force	Force	Swept	Swept	Wt.	RETAIL: 01-10-2022
	Stroke	Dia.	Size	Pin	Bore	stroke	O/D	Length	Centre	Centre	Rod	Piston	Volume	Volume	Kgs	
	inch	inch	Npt	Dia.	mm	mm	mm	mm	mm	mm	180 bar	180 bar	Rod	Piston	+/-	
											Tons	Tons	Litres	Litres		
81H-30006-125	3" x 6"	1-1/4"	1/2"	1"	76.2	152	31.75	210	413	565	6.74	8.16	0.57	0.69	10.1	
81H-30008-125	3" x 8"	1-1/4"	1/2"	1"	76.2	203	31.75	261	464	667	6.74	8.16	0.76	0.93	11	
81H-30008-150	3" x 8"	1-1/2"	1/2"	1"	76.2	203	38.1	261	464	667	6.11	8.16	0.69	0.93	12.1	
81H-30008-125A	3" x 8" A*	1-1/4"	1/2"	1"	76.2	203	31.75	261	514	717	6.74	8.16	0.76	0.93	11.3	
81H-30008-150A	3" x 8" A*	1-1/2"	1/2"	1"	76.2	203	38.1	261	514	717	6.11	8.16	0.69	0.93	12.4	
81H-30010-125	3" x 10"	1-1/4"	1/2"	1"	76.2	254	31.75	311	514	768	6.74	8.16	0.96	1.16	13.7	
81H-30010-150	3" x 10"	1-1/2"	1/2"	1"	76.2	254	38.1	311	514	768	6.11	8.16	0.87	1.16	15	
81H-30012-125	3" x 12"	1-1/4"	1/2"	1"	76.2	305	31.75	362	565	870	6.74	8.16	1.15	1.39	12.8	
81H-30012-150	3" x 12"	1-1/2"	1/2"	1"	76.2	305	38.1	362	565	870	6.11	8.16	1.04	1.39	14	
81H-30014-125	3" x 14"	1-1/4"	1/2"	1"	76.2	356	31.75	413	616	972	6.74	8.16	1.34	1.62	13.7	
81H-30014-150	3" x 14"	1-1/2"	1/2"	1"	76.2	356	38.1	413	616	972	6.11	8.16	1.22	1.62	15.1	
81H-30016-125	3" x 16"	1-1/4"	1/2"	1"	76.2	406	31.75	464	667	1073	6.74	8.16	1.53	1.85	14.8	
81H-30016-150	3" x 16"	1-1/2"	1/2"	1"	76.2	406	38.1	464	667	1073	6.11	8.16	1.39	1.85	16.3	
81H-30018-125	3" x 18"	1-1/4"	1/2"	1"	76.2	457	31.75	515	718	1175	6.74	8.16	1.72	2.08	15.8	
81H-30018-150	3" x 18"	1-1/2"	1/2"	1"	76.2	457	38.1	515	718	1175	6.11	8.16	1.56	2.08	17.4	
81H-30020-125	3" x 20"	1-1/4"	1/2"	1"	76.2	508	31.75	565	768	1276	6.74	8.16	1.91	2.32	16.8	
81H-30020-150	3" x 20"	1-1/2"	1/2"	1"	76.2	508	38.1	565	768	1276	6.11	8.16	1.74	2.32	18.5	
81H-30024-150	3" x 24"	1-1/2"	1/2"	1"	76.2	610	38.1	667	870	1480	6.11	8.16	2.09	2.78	21	
81H-30028-150	3" x 28"	1-1/2"	1/2"	1"	76.2	711	38.1	769	972	1683	6.11	8.16	2.43	3.24	23.6	
81H-30030-150	3" x 30"	1-1/2"	1/2"	1"	76.2	762	38.1	819	1022	1784	6.11	8.16	2.60	3.47	24.43	
81H-30036-150	3" x 36"	1-1/2"	1/2"	1"	76.2	914	38.1	972	1175	2089	6.11	8.16	3.12	4.17	28.2	
81H-30048-150	3" x 48"	1-1/2"	1/2"	1"	76.2	1219	38.1	1277	1480	2699	6.11	8.16	4.17	5.56	43.2	
81H-30080-150	3" x 80"	1-1/2"	1/2"	1"	76.2	2032	38.1	2090	2292	4324	6.11	8.16	6.95	9.26	52	
81H-30120-150	3" x 120"	1-1/2"	1/2"	1"	76.2	3048	38.1	3105	3308	6356	6.11	8.16	10.42	13.89	75	





# TAK - BOK

## 4" Bore Cylinders

### TIE ROD TYPE



Part Number	Bore x	Rod	Port	Clevis	Barrel	Shaft	Shaft	Barrel	Closed	Open	Force	Force	Swept	Swept	Wt.	RETAIL: 01-10-2022
	Stroke	Dia.	Size	Pin	Bore	stroke	O/D	Length	Centre	Centre	Rod	Piston	Volume	Volume	Kgs	
	inch	inch	Npt	Dia.	mm	mm	mm	mm	mm	mm	180 bar Tons	180 bar Tons	Rod Litres	Piston Litres	+/-	
81H-40008-200	4" x 8"	2"	1/2"	1"	101.6	203	50.8	261	464	667	10.76	14.41	1.23	1.64	18	
81H-40008-200A	4" x 8" A*	2"	1/2"	1"	101.6	203	50.8	261	514	717	10.76	14.41	1.23	1.64	18.4	
81H-40010-200	4" x 10"	2"	1/2"	1"	101.6	254	50.8	311	514	768	10.76	14.41	1.54	2.06	19.1	
81H-40012-200	4" x 12"	2"	1/2"	1"	101.6	305	50.8	362	565	870	10.76	14.41	1.85	2.47	20.6	
81H-40014-200	4" x 14"	2"	1/2"	1"	101.6	356	50.8	413	616	972	10.76	14.41	2.16	2.88	0.72	
81H-40016-200	4" x 16"	2"	1/2"	1"	101.6	406	50.8	464	667	1073	10.76	14.41	2.47	3.29	23.5	
81H-40018-200	4" x 18"	2"	1/2"	1"	101.6	457	50.8	515	718	1175	10.76	14.41	2.78	3.70	25.2	
81H-40020-200	4" x 20"	2"	1/2"	1"	101.6	508	50.8	565	768	1276	10.76	14.41	3.09	4.12	28.5	
81H-40024-200	4" x 24"	2"	1/2"	1"	101.6	610	50.8	667	870	1480	10.76	14.41	3.71	8.65	1.24	
81H-40028-200	4" x 28"	2"	1/2"	1"	101.6	711	50.8	769	972	1683	10.76	14.41	4.32	5.76	40.2	
81H-40030-200	4" x 30"	2"	1/2"	1"	101.6	762	50.8	819	1022	1784	10.76	14.41	4.63	6.17	42.2	
81H-40036-200	4" x 36"	2"	1/2"	1"	101.6	914	50.8	972	1175	2089	10.76	14.41	5.55	7.41	47.5	
81H-40048-200	4" x 48"	2"	1/2"	1"	101.6	1219	50.8	1277	1480	2699	10.76	14.41	7.41	9.88	56.2	
81H-40080-200	4" x 80"	2"	1/2"	1"	101.6	2032	50.8	2090	2292	4324	10.76	14.41	12.35	16.47	89.3	
81H-400120-200	4" x 120"	2"	1/2"	1"	101.6	3048	50.8	3105	3308	6356	10.76	14.41	18.52	24.70	128	



# TAK - BOK CYLINDER SPARES TIE ROD TYPE

Part Number	DESCRIPTION FOR ; 2" SPARES	RETAIL:
	<b>DESCRIPTION FOR ; 2" SPARES</b>	<b>01-10-2022</b>
81H-20-SKIT-NWO	2" SEAL KIT ; "O" RING DESIGN ; FOR SHAFT 1-1/16"	
81H-20-SKIT-NBU	2" SEAL KIT ; U SEAL DESIGN ; FOR SHAFT 1-1/16"	
81H-20-56891	2" ROD CLEVIS 1-1/16" OD SHAFT ; THREAD 1-1/16"- UNF	
81H-20-040001	2" ROD CLEVIS 1-1/16" OD SHAFT ; LOCKING SCREW TYPE 80" - 120" STROKE	
81H-A03-20A0C0	LOCKING SCREW FOR CLEVIS FOR 2" 3" 4"	
81H-N600001-2	LOCKING SCREW NYLON BLOCK FOR CLEVIS FOR 2" 3" 4"	
81H-20-59626	2" ROD CLEVIS PIN ; 1" OD	
81H-20-63512	2" R CLIP FOR PIN ; 1" OD	
81H-20-62538	2" HEAD ROD CAP ; "O" RING DESIGN ; FOR SHAFT 1-1/16"	
81H-20-62538NBU	2" HEAD ROD CAP ; U SEAL DESIGN ; FOR SHAFT 1-1/16"	
81H-20-59842	2" BASE BOTTOM CLEVIS 2 PORTS 3/8" NPT	
81H-20-59847	2" PISTON	
81H-20-P-NUT	2" PISTON NUT	
	<b>DESCRIPTION FOR ; 3" SPARES</b>	
81H-30-SKIT-NWO	3" SEAL KIT ; "O" RING DESIGN ; FOR SHAFT 1-1/4"	
81H-30-SKIT-NBO	3" SEAL KIT ; "O" RING DESIGN ; FOR SHAFT 1-1/2"	
81H-30-SKIT-NWU	3" SEAL KIT ; U SEAL DESIGN ; FOR SHAFT 1-1/4"	
81H-30-SKIT-NBU	3" SEAL KIT ; U SEAL DESIGN ; FOR SHAFT 1-1/2"	
81H-30-56892	3" ROD CLEVIS 1-1/4" & 1-1/2" OD SHAFT ; THREAD 1-1/4"- UNF; FOR BOTH SHAFT O/D	
81H-3040-040001	3" AND 4" ROD CLEVIS 1-1/2" & 2" OD SHAFT ; LOCKING SCREW 80" - 120" STROKE	
81H-A03-20A0C0	LOCKING SCREW FOR CLEVIS FOR 2" 3" 4"	
81H-N600001-2	LOCKING SCREW NYLON BLOCK FOR CLEVIS FOR 2" 3" 4"	
81H-30-59626	3" ROD CLEVIS PIN ; 1" OD	
81H-30-63512	3" R CLIP FOR PIN ; 1" OD	
81H-30-62541	3" HEAD ROD CAP ; "O" RING DESIGN ; FOR SHAFT 1-1/4"	
81H-30-62542	3" HEAD ROD CAP ; "O" RING DESIGN ; FOR SHAFT 1-1/2"	
81H-30-62541-NB	3" HEAD ROD CAP ; U SEAL DESIGN ; FOR SHAFT 1-1/4"	
81H-30-62542-NB	3" HEAD ROD CAP ; U SEAL DESIGN ; FOR SHAFT 1-1/2"	
81H-30-59844	3" BASE BOTTOM CLEVIS 2 PORTS 1/2" NPT	
81H-30-59849	3" PISTON	
81H-30-P-NUT	3" PISTON NUT	
	<b>DESCRIPTION FOR ; 4" SPARES</b>	
81H-40-SKIT-NWO	4" SEAL KIT ; "O" RING DESIGN ; FOR SHAFT 2"	
81H-40-SKIT-NBU	4" SEAL KIT ; U SEAL DESIGN ; FOR SHAFT 2"	
81H-40-56893	4" ROD CLEVIS 2" OD SHAFT ; THREAD 1-1/2"- UNF	
81H-3040-040001	3" AND 4" ROD CLEVIS 1-1/2" & 2" OD SHAFT ; LOCKING SCREW 80" - 120" STROKE	
81H-A03-20A0C0	LOCKING SCREW FOR CLEVIS FOR 2" 3" 4"	
81H-N600001-2	LOCKING SCREW NYLON BLOCK FOR CLEVIS FOR 2" 3" 4"	
81H-40-59626	4" ROD CLEVIS PIN ; 1" OD	
81H-40-63512	4" R CLIP FOR PIN ; 1" OD	
81H-40-62549	4" HEAD ROD CAP ; "O" RING DESIGN ; FOR SHAFT 2"	
81H-40-62549-NB	4" HEAD ROD CAP ; U SEAL DESIGN ; FOR SHAFT 2"	
81H-40-59846	4" BASE BOTTOM CLEVIS 2 PORTS 1/2" NPT	
81H-40-59851	4" PISTON	
81H-40-P-NUT	4" PISTON NUT	



# TIE ROD CYLINDER TECHNICAL

## HOW TO IDENTIFY TAK - BOK CYLINDERS

Barrel	Barrel	Barrel	*** How to work out closed centre	Cylinder
I/D	I/D	O/D	Measure barrel length in ? mm + 203 mm	Size
2"	50.8 mm	61 mm	Example ; TK 2008 -106 ( 261 + 203 ) = 464 mm C/C	2"
3"	76.2 mm	86 mm	Example ; TK 3008 -125 ( 261 + 203 ) = 464 mm C/C	3"
4"	101.6 mm	112 mm	Example ; TK 4008 -200 ( 261 + 203 ) = 464 mm C/C	4"

\*\*\* How to work out closed centre with no sample; use ( 260.4 mm ) + ( stroke mm ) = closed centre in mm

Barrel	Barrel	Barrel	*** How to work out open centre	Cylinder
I/D	I/D	O/D	Measure closed centre in ? mm + stroke in mm	Size
2"	50.8 mm	61 mm	Example ; TK 2008 -106 ( 464 + 203 ) = 667 mm C/C	2"
3"	76.2 mm	86 mm	Example ; TK 3008 -125 ( 464 + 203 ) = 667 mm C/C	3"
4"	101.6 mm	112 mm	Example ; TK 4008 -200 ( 464 + 203 ) = 667 mm C/C	4"

How to work out threads				
Bore Diameter	2" ( 50.8 mm )	3" ( 76.2 mm )	4" (101.6 mm)	
Shaft Diameter	1-1/16" (27mm)	1-1/4" (31.75mm)	1-1/2" (38.1mm)	2" (50.8mm)
Thread U N F	1-1/16" - 12 UNF	1-1/4" - 12 UNF		1-1/2" - 12 UNF
Ports N P T	3/8"	1/2"		1/2"

**NOTE: A\* - SHAFT STROKE FOR ASAE TYPE CYLINDERS, YOU MUST ADD AN EXTRA 50.8 mm OR 2"**

## BUCKLING LOADS FOR TIE ROD CYLINDERS

### 2" CYLINDER

BUCKLING LOADS		STROKE		
Bore 2"	Shaft 1-1/16	6" TO 18"	20" TO 24"	28" TO 36"
		Stable Region Safety 3:1	Safety 2:1	Safety 1:1

### 3" CYLINDER

BUCKLING LOADS		STROKE		
Bore 3"	Shaft 1-1/4"	6" TO 16"	18" TO 20"	24" TO 36"
Bore 3"	Shaft 1-1/2"	6" TO 24"	28" TO 36"	
		Stable Region Safety 3:1	Safety 2:1	Safety 1:1

### 4" CYLINDER

BUCKLING LOADS		STROKE		
Bore 4"	Shaft 2"	8" TO 36"		
		Stable Region Safety 3:1	Safety 2:1	Safety 1:1

## CYLINDER DIMENSIONS

BORE	A***	B	C	E & G	H & I	J	M	Q	V
2"	10.25"	0.188"	3/8"	2.441"	1.125"	2.125"	2"	1-1/16"	2.874"
50.8 mm	260.4 mm	4.8 mm	NPT	62 mm	29 mm	54 mm	50.8 mm	UNF	73 mm
3"	10.25"	0.188"	1/2"	2.717"	1.125"	2.125"	2"	1-1/4"	3.78"
76.2 mm	260.4 mm	4.8 mm	NPT	69 mm	29 mm	54 mm	50.8 mm	UNF	96mm
4"	10.25"	0.25"	1/2"	2.717"	1.125"	2.125"	2.118"	1-1/2"	5.039"
101.6 mm	260.4 mm	6.35 mm	NPT	69 mm	29 mm	54 mm	53.8 mm	UNF	128 mm

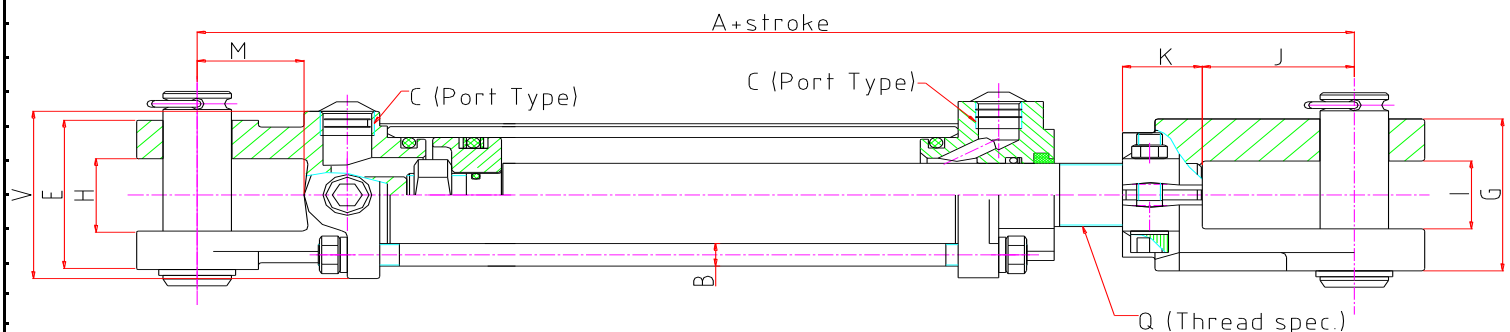

# TAK - BOK

## 2" Bore Cylinders

### WELDED TYPE

Part Number	Bore x	Rod	Port	Clevis	Barrel	Shaft	Shaft	Barrel	Closed	Open	Force	Force	Swept	Swept	Wt.	RETAIL: 01-01-2023
	Stroke	Dia.	Size	Pin	Bore	stroke	O/D	Length	Centre	Centre	Rod	Piston	Volume	Volume	Kgs	
	inch	inch	Bsp	Dia.	mm	mm	mm	mm	mm	mm	250 bar	250 bar	Rod	Piston	+/-	
											Tons	Tons	Litres	Litres		
81H-WC20006-113	2" x 6"	1-1/8"	3/8"	1"	50.8	152	28.7	242	413	565	3.4	5	0.21	0.31	6.1	
81H-WC20008-113	2" x 8"	1-1/8"	3/8"	1"	50.8	203	28.7	293	464	667	3.4	5	0.28	0.41	6.7	
81H-WC20010-113	2" x 10"	1-1/8"	3/8"	1"	50.8	254	28.7	344	514	768	3.4	5	0.35	0.51	7.3	
81H-WC20012-113	2" x 12"	1-1/8"	3/8"	1"	50.8	305	28.7	395	565	870	3.4	5	0.42	0.62	7.9	
81H-WC20014-113	2" x 14"	1-1/8"	3/8"	1"	50.8	356	28.7	446	616	972	3.4	5	0.49	0.72	8.5	
81H-WC20016-113	2" x 16"	1-1/8"	3/8"	1"	50.8	406	28.7	496	667	1073	3.4	5	0.56	0.82	9.1	
81H-WC20018-113	2" x 18"	1-1/8"	3/8"	1"	50.8	457	28.7	547	718	1175	3.4	5	0.63	0.93	9.7	
81H-WC20020-113	2" x 20"	1-1/8"	3/8"	1"	50.8	508	28.7	598	768	1276	3.4	5	0.70	1.03	10.3	
81H-WC20024-113	2" x 24"	1-1/8"	3/8"	1"	50.8	610	28.7	700	870	1480	3.4	5	0.84	1.24	11.4	
81H-WC20030-113	2" x 30"	1-1/8"	3/8"	1"	50.8	762	28.7	852	1022	1784	3.4	5	1.05	1.54	13.2	
81H-WC20036-113	2" x 36"	1-1/8"	3/8"	1"	50.8	914	28.7	1004	1175	2089	3.4	5	1.26	1.85	14.9	





Part Number	TAK - BOK															RETAIL:
	3" Bore Cylinders															
	WELDED TYPE															
Stroke	Bore x	Rod	Port	Clevis	Barrel	Shaft	Shaft	Barrel	Closed	Open	Force	Force	Swept	Swept	Wt.	01-01-2023
inch	inch	inch	Bsp	Pin	Bore	stroke	O/D	Length	Centre	Centre	Rod	Piston	Volume	Volume	Kgs	
				mm	mm	mm	mm	mm	mm	mm	250 bar	250 bar	Rod	Piston	+/-	
				mm	mm	mm	mm	mm	mm	mm	Tons	Tons	Litres	Litres		
81H-WC30006-150	3" x 6"	1-1/2"	1/2"	1"	76.2	152	38.1	252	413	565	8.5	11.5	0.52	0.69	11.1	
81H-WC30008-150	3" x 8"	1-1/2"	1/2"	1"	76.2	203	38.1	303	464	667	8.5	11.5	0.69	0.93	12.2	
81H-WC30008150A	3" x 8" A*	1-1/2"	1/2"	1"	76.2	203	38.1	303	514	717	8.5	11.5	0.69	0.93	12.7	
81H-WC30010-150	3" x 10"	1-1/2"	1/2"	1"	76.2	254	38.1	354	514	768	8.5	11.5	0.87	1.16	13.4	
81H-WC30012-150	3" x 12"	1-1/2"	1/2"	1"	76.2	305	38.1	405	565	870	8.5	11.5	1.04	1.39	14.5	
81H-WC30014-150	3" x 14"	1-1/2"	1/2"	1"	76.2	356	38.1	456	616	972	8.5	11.5	1.22	1.62	15.6	
81H-WC30016-150	3" x 16"	1-1/2"	1/2"	1"	76.2	406	38.1	506	667	1073	8.5	11.5	1.39	1.85	16.6	
81H-WC30018-150	3" x 18"	1-1/2"	1/2"	1"	76.2	457	38.1	557	718	1175	8.5	11.5	1.56	2.08	17.7	
81H-WC30020-150	3" x 20"	1-1/2"	1/2"	1"	76.2	508	38.1	608	768	1276	8.5	11.5	1.74	2.32	18.8	
81H-WC30024-150	3" x 24"	1-1/2"	1/2"	1"	76.2	610	38.1	710	870	1480	8.5	11.5	2.09	2.78	21.1	
81H-WC30028-150	3" x 28"	1-1/2"	1/2"	1"	76.2	711	38.1	811	972	1683	8.5	11.5	2.43	3.24	23.1	
81H-WC30030-150	3" x 30"	1-1/2"	1/2"	1"	76.2	762	38.1	862	1022	1784	8.5	11.5	2.60	3.47	24.3	
81H-WC30036-150	3" x 36"	1-1/2"	1/2"	1"	76.2	914	38.1	1014	1175	2089	8.5	11.5	3.12	4.17	27.6	
81H-WC30048-150	3" x 48"	1-1/2"	1/2"	1"	76.2	1219	38.1	1319	1480	2699	8.5	11.5	4.17	5.56	34.1	
81H-WC30120-150	3" x 120"	1-1/2"	1/2"	1"	76.2	3048	38.1	3148	3308	6356	8.5	11.5	10.42	13.89	73.8	







**TAK - BOK**  
**CYLINDER SPARES**  
**WELDED TYPE**



Part Number

RETAIL:

DESCRIPTION FOR ; 2" SPARES

01-01-2023

81H-20-SKIT-W

2" SEAL KIT

81H-20-CLV2001

MALE ROD END CLEVIS 2"

81H-20-WBC2003

MALE BASE BOTTOM CLEVIS 2"



DESCRIPTION FOR ; 3" SPARES

81H-30-SKIT-W

3" SEAL KIT

81H-30-CLV3001

MALE ROD END CLEVIS 3"

81H-30-WBC3002

MALE BASE BOTTOM CLEVIS 3"



# WELDED CYLINDER TECHNICAL

## CYLINDER DIMENSIONS

PART NUMBER	STROKE	RETRACTED	PART NUMBER	STROKE	RETRACTED
81H-WC20006-113	152.4 (6.00")	412.75 (16.25")	81H-WC20018-113	457.2 (18.00")	717.55 (28.25")
81H-WC20008-113	203.2 (8.00")	463.55 (18.25")	81H-WC20020-113	508.0 (20.00")	768.35 (30.25")
81H-WC20012-113	304.8 (12.00")	565.15 (22.25")	81H-WC20024-113	609.6 (24.00")	869.95 (34.25")
81H-WC20014-113	355.6 (14.00")	615.95 (24.25")	81H-WC20030-113	762.0 (30.00")	1022.35 (40.25")
81H-WC20016-113	406.4 (16.00")	666.75 (26.25")	81H-WC20036-113	914.4 (36.00")	1174.75 (46.25")

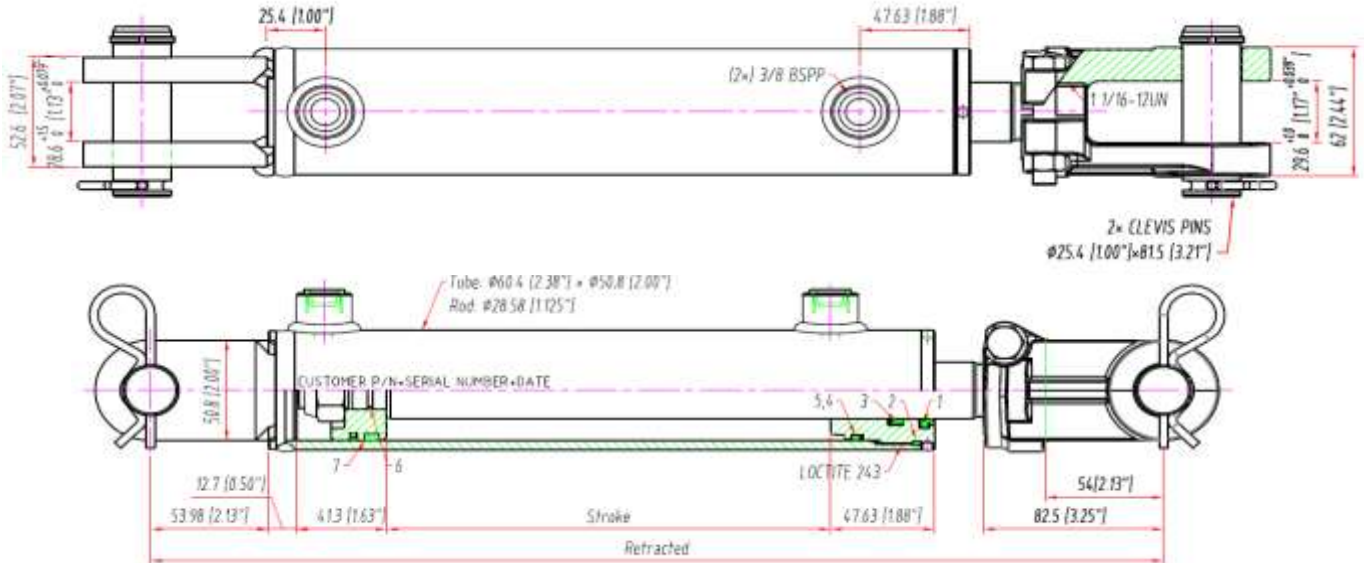

## CYLINDER DIMENSIONS

PART NUMBER	STROKE	RETRACTED	PART NUMBER	STROKE	RETRACTED
81H-WC30006-150	152.4 (6.00")	412.75 (16.25")	81H-WC30020-150	508.0 (20.00")	768.35 (30.25")
81H-WC30008-150	203.2 (8.00")	463.55 (18.25")	81H-WC30024-150	609.6 (24.00")	869.95 (34.25")
81H-WC30008-150A	203.2 (8.00")	514.35 (20.25")	81H-WC30028-150	711.2 (28.00")	971.55 (38.25")
81H-WC30010-150	355.6 (14.00")	615.95 (24.25")	81H-WC30030-150	762.0 (30.00")	1022.35 (40.25")
81H-WC30012-150	304.8 (12.00")	565.15 (22.25")	81H-WC30036-150	914.4 (36.00")	1174.75 (46.25")
81H-WC30014-150	355.6 (14.00")	615.95 (24.25")	81H-WC30048-150	1219.2 (48.00")	1479.55 (58.25")
81H-WC30016-150	406.4 (16.00")	666.75 (26.25")	81H-WC30120-150	3048.0 (120.00")	3308.35 (130.25")
81H-WC30018-150	457.2 (18.00")	717.55 (28.25")			

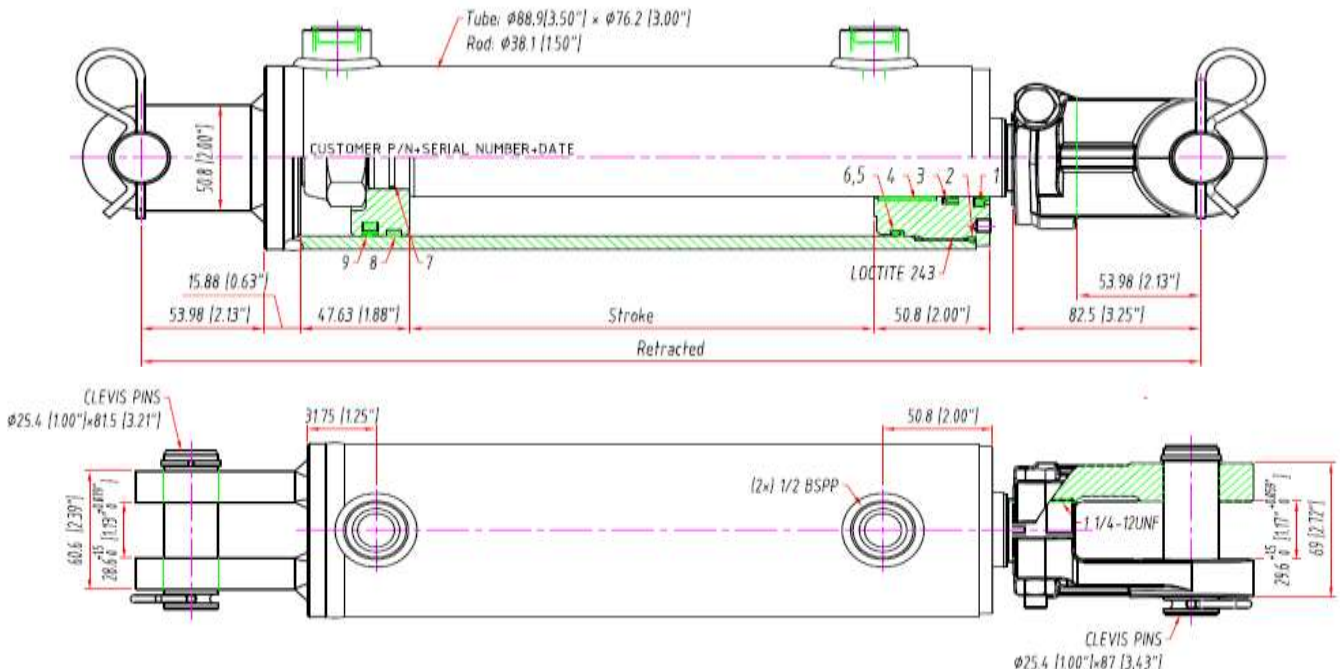

**CBT SERIES HI / LOW PUMPS**

72H-C-6-3-2-1	PUMP CBT 6.3 cc - 2.1 cc
72H-C-10-9-3-6	PUMP CBT 10.9 cc - 3.6 cc
72H-C-22-9-7-6	PUMP CBT 22.9 cc - 7.6 cc

**TECHNICAL SPECS ON CBT SERIES 210 Bar**

SHAFT	SPIGOT	MOUNT	SUCTION	PRESSURE	ROTATION
1/2" P/Key	45.25mm	4 BOLT 50.08 X 50.08	25.4mm PIPE	1/2" NPT	C/W
5/8" P/KEY	3-1/4"	2 BOLT	1" NPT	3/4" NPT	C/W

**LOG SPLITTER VALVE**

72H-LS-TW-20F	LS-TW LOG SPLITTER VALVE HAND OPERATED ONE WAY WITH DETENT PRESSURE RELEASE
---------------	---

**LOG SPLITTER CYLINDER**

82H-TKLOG518	LOG SPLITTER CYLINDER 125 X 810 X 1267 X 75
--------------	---

**SPECS**

LOG SPLITTER CYLINDER 25 TONS @ 210 BAR PISTON SIDE
BORE 125mm
CLOSED CENTRE 810mm
OPEN CENTRE 1267mm
STROKE 457mm
SHAFT OD 75mm



# STANDARD PUMP PORTS

## BSPB THREADED PORTS

PORT SIZE	THREAD	THREAD OD	DRILL SIZE
1/8"	1/8" - 28 tpi	9.5	8.8
1/4"	1/4" - 19 tpi	13	11.8
3/8"	3/8" - 19 tpi	16.5	15.5
1/2"	1/2" - 14 tpi	21	19
5/8"	5/8" - 14 tpi	22.7	21
3/4"	3/4" - 14 tpi	26.2	24.5
1"	1" - 11 tpi	33	31
1-1/4"	1-1/4" - 11 tpi	41.8	40
1-1/2"	1-1/2" - 11 tpi	47.4	45.5
2"	2" - 11 tpi	59.3	57

## BOSCH SQUARE FLANGED PORTS

PORT SIZE mm	P C D mm	THREAD mm	DRILL SIZE
8	30	M6 x 1	5
12	30	M6 x 1	5
15	35	M6 x 1	5
20	40	M6 x 1	5
18	55	M8 x 1.25	6.5
26	55	M8 x 1.25	6.5

## DIAMOND FLANGED PORTS

PORT SIZE mm	P C D mm	THREAD mm	DRILL SIZE
13	30	M6 x 1	5
19	40	M8 x 1.25	6.5
27	51	M10 x 1.5	8.5
34	56	M10 x 1.5	8.5
36	62	M10 x 1.5	8.5
45	72	M12 x 1.75	10

## NPT THREADED PORTS

PORT SIZE	THREAD	THREAD OD	DRILL SIZE
1/8"	1/8" - 27 tpi	9.2	8.8
1/4"	1/4" - 18 tpi	13	10.7
3/8"	3/8" - 18 tpi	16.4	14.25
1/2"	1/2" - 14 tpi	20.5	17.5
3/4"	3/4" - 14 tpi	25.7	22.75
1"	1" - 11-1/2"	31.5	28.5
1-1/4"	1-1/4" - 11-1/2"	41.3	37.5
1-1/2"	1-1/2" - 11-1/2"	47.3	43.5
2"	2" - 11-1/2"	59.5	55

## S.A.E 4 BOLT FLANGE 3000 SERIES

FLANGE SIZE	DIMENSIONS			SCREWS			
	C	E	H	METRIC	DRILL	UNC	DRILL
1/2"	38.1	17.48	16	M08	6.50	5/16	6.50
3/4"	47.63	22.23	18	M10	8.50	3/8	8.00
1"	52.37	26.19	18	M10	8.50	3/8	8.00
1 1/4"	58.72	30.18	21	M10	8.50	7/16	9.50
1 1/2"	69.85	35.71	25	M12	10.00	1/2	10.50
2"	77.77	42.88	25	M12	10.00	1/2	10.50
2 1/2"	88.9	50.80	25	M12	10.00	1/2	10.50
3"	106.38	61.93	27	M16	14.00	5/8	13.50
3 1/2"	120.65	69.85	27	M16	14.00	5/8	13.50
4"	130.18	77.77	27	M16	14.00	5/8	13.50

NOTE: NPT THREAD OD TAKEN FROM SMALLEST SIZE

## S. A. E. "O" THREADED PORTS

PORT SIZE	THREAD	THREAD OD	DRILL SIZE
1/4"	7/16" - 20UNF	11	9.9
5/6"	1/2" - 20 UNF	12.5	11.6
3/8"	9/16" - 18UNF	14	13
1/2"	3/4" - 16UNF	19	17.5
5/8"	7/8" - 14UNF	22	20.5
3/4"	1" - 1/16- 12UN	26.8	24.5
1"	1" - 5/16- 12UN	32.2	31.2
1 1/4"	1" - 5/8 - 12UN	41	39
1 1/2"	1" - 7/8 - 12UN	47.2	45.5
2"	2" - 1/2 - 12UN	63	61

## S.A.E 4 BOLT FLANGE 6000 SERIES

FLANGE SIZE	DIMENSIONS			SCREWS			
	C	E	H	METRIC	DRILL	UNC	DRILL
1/2"	40.49	18.24	16	M08	6.50	5/16	6.50
3/4"	50.80	23.80	21	M10	8.50	3/8	8.00
1"	57.15	27.76	25	M12	10.00	7/16	9.50
1 1/4"	66.68	31.75	27	M14	12.00	1/2	10.50
1 1/2"	79.38	36.50	30	M16	14.00	5/8	13.50
2"	96.82	44.45	37	M20	17.50	3/4	16.50

## DOWTY FLANGED PORTS

PORT SIZE	P C D mm	THREAD mm	DRILL SIZE
P1 17.3	43	5/16" - 18UNC	6.6
P1 17.3	43	5/16" - 18UNC	6.6
P2 21.6	48	5/16" - 18UNC	6.6
P2 21.7	48	5/16" - 18UNC	6.6

### DIAMOND PORTS



S.A.E. 4 BOLT

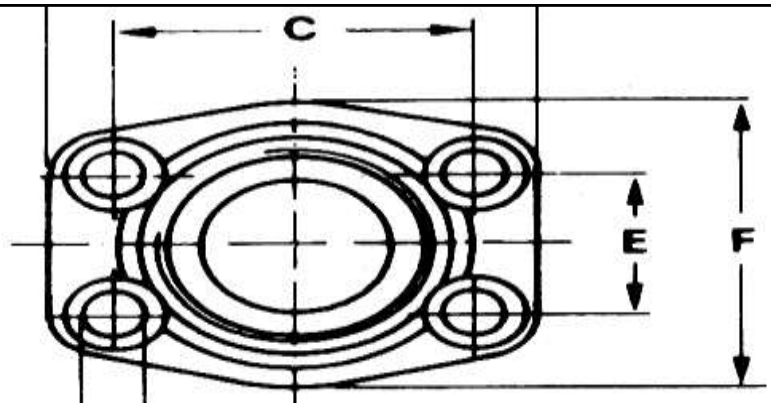

## HYDRAULIC WORKSHOP FORMULAE

### CYLINDER FORCE ; IN KILOGRAMS (KG)

$$\text{Kg} = \text{AREA} \times \text{PRESSURE} = \text{DIAMETER (cm)} \times \text{DIAMETER (cm)} \times \text{PRESSURE (bar)} \times 3.14 \div 4$$

$$\text{Kg} = 10.1 \text{ cm} \times 10.1 \text{ cm} \times 180 \text{ Bar} \times 3.14 \div 4 = 14414 \text{ Kg}$$

$$\text{tons} = \text{Kg} \div 1000$$

$$14414 \text{ Kg} \div 1000 = 14.41 \text{ tons}$$

### CYLINDER CAPACITY FLOW RATE ; IN LITRES PER MINUTE ( L/min )

$$\text{L/min} = \text{AREA} \times \text{SPEED} = \text{DIAMETER (cm)} \times \text{DIAMETER (cm)} \times \text{SPEED (m/s)} \times 4.71$$

$$\text{L/min} = 10.1 \text{ cm} \times 10.1 \text{ cm} \times .02 \text{ m/s} \times 4.71 = 9 \text{ L/min}$$

### CYLINDER SHAFT SPEED ; IN MILLIMETERS PER SEC (M/S)

$$\text{m/s} = \text{FLOW RATE} \div \text{AREA} = \text{FLOW RATE ( L/min)} \div \text{DIAMETER (cm)} \div \text{DIAMETER (cm)} \times 0.21$$

$$\text{m/s} = 9 \text{ L/min} \div 10.1 \text{ cm} \div 10.1 \text{ cm} \times .21 = .02 \text{ m/s} = 20 \text{ mm/s}$$

### CYLINDER STROKE TIME ; IN SECONDS PER STROKE

$$\text{sec} = \text{STROKE LENGTH (cm)} \div \text{SPEED (m/s)} \div 100$$

$$\text{sec} = 10 \text{ cm} \div .02 \text{ m/s} \div 100 = 5 \text{ sec}$$

### PUMP FLOW : IN LITRES PER MINUTE ( L/min )

$$\text{L/min} = \text{cc / Rev} \times \text{RPM} \div 1000$$

$$\text{L/min} = 14 \text{ cc/Rev} \times 1450 \text{ RPM} \div 1000 = 20.3 \text{ L/min}$$

### PUMP INPUT POWER ; IN KILOWATTS ( MILLIMETERS )

$$\text{Kw} = \text{FLOW} \times \text{PRESSURE} \div 600 \div 0.85$$

$$\text{Kw} = 20 \text{ LITRES} \times 180 \text{ Bar} \div 600 \div 0.85 = 7 \text{ KW ( KILOWATT )}$$

### MOTOR TORQUE ; IN NEWTON METER (Nm)

$$\text{Nm} = \text{PRESSURE (MPa)} \times \text{FLOW (L/min)} \times 159 \div \text{RPM}$$

$$\text{Nm} = 21 \text{ MPa} \times 9 \text{ L/min} \times 159 \div 1450 \text{ RPM} = 20.72 \text{ Nm}$$

### MOTOR TORQUE ; IN NEWTON METER (Nm)

$$\text{Nm} = \text{PRESSURE (MPa)} \times \text{DISPLACEMENT (cm}^3\text{)} \div 6.28$$

$$\text{Nm} = 21 \text{ MPa} \times 10 \text{ cm}^3 \div 6.28 = 33.44 \text{ Nm}$$

### PUMP SHAFT PL FACTOR ; IN TORQUE NEWTON METER ( Nm )

$$\text{Nm} = \text{cc / Rev} \times \text{bar} / 57.2 = \text{Nm ( NEWTON METER )}$$

$$\text{Nm} = 14 \text{ cc / Rev} \times 140 \text{ bar} \div 57.2 = 34 \text{ Nm}$$

### CONVERSION FACTORS

$$1 \text{ Kw} = 1.34 \text{ HP}$$

$$1 \text{ HP} = 0.75 \text{ Kw}$$

$$1 \text{ Kw} = 1000 \text{ Watts}$$

$$1000 \text{ Kg} = 1 \text{ TON METRIC}$$

$$1 \text{ KILOGRAM} = 2.2 \text{ Lbs}$$

$$1 \text{ NEWTON METER ( nm )} = 8.9 \text{ in-Lbs.}$$

$$1 \text{ NEWTON METER ( nm )} = 0.74 \text{ ft-Lbs.}$$

$$10 \text{ NEWTON METERS ( nm )} = 1 \text{ Dnm}$$

$$1 \text{ US Gal} = 3.79 \text{ Litre}$$

$$1 \text{ Imp. Gallon} = 4.5 \text{ LITRE}$$

$$1 \text{ cu Inch} = 16.4 \text{ cc}$$

$$1 \text{ Inch} = 25.4 \text{ mm}$$

$$1 \text{ METER} = 39.4 \text{ Inch}$$

$$0.01 \text{ mm} = 4 \text{ thousands of an Inch}$$

$$1 \text{ bar} = 14.5 \text{ PSI}$$

$$1 \text{ MPA} = 10 \text{ bar}$$

$$1 \text{ bar} = 100 \text{ Kpa}$$



**FORMULA TO WORK OUT GEAR PUMP CAPACITY**

**HOW TO WORK OUT APPROXIMATE FLOW CAPACITY  
OF A GEAR PUMP IN LITRES PER MINUTE  
AT 1450 RPM. ( OR IN  $\text{cm}^3$  PER REVOLUTION)**

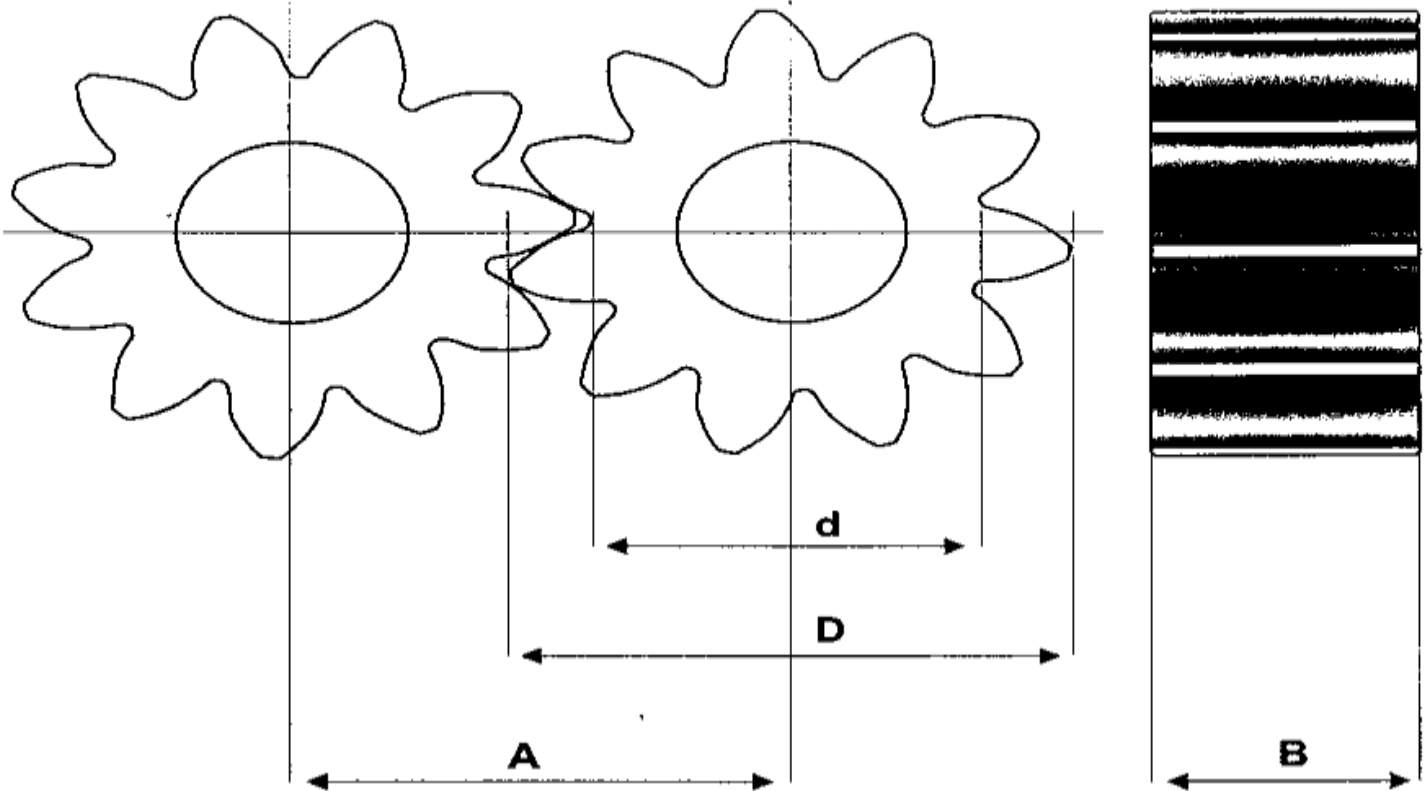

**FORMULA: USING TWO GEARS**

**NOTE: ALL DIMENSIONS IN MM  $\div$  BY 1000 TO GET CC/REV.**

**A = CENTRE TO CENTRE OF SHAFTS**

**B = GEAR WIDTH**

**D = GEAR OD**

**d = GEAR ID**

$$1.3682 \times A \times B \times (D-d)$$

**EXAMPLE**

$$1.3682 \times 44.3 \times 32 \times (53.3-33.5) \\ = 38403.2 \div \text{BY } 1000 \text{ TO GET CC/REV.} \\ 38.4 \text{ CC/REV.}$$

**FORMULA: USING ONE GEAR (NOT AS ACCURATE)**

$$\text{FORMULA; } (D^2 - d^2) \times B \times \frac{\pi}{4}$$



# PUMPS GEAR ALUMINIUM ROTATION CHANGE

## GROUP 2 & GROUP 3

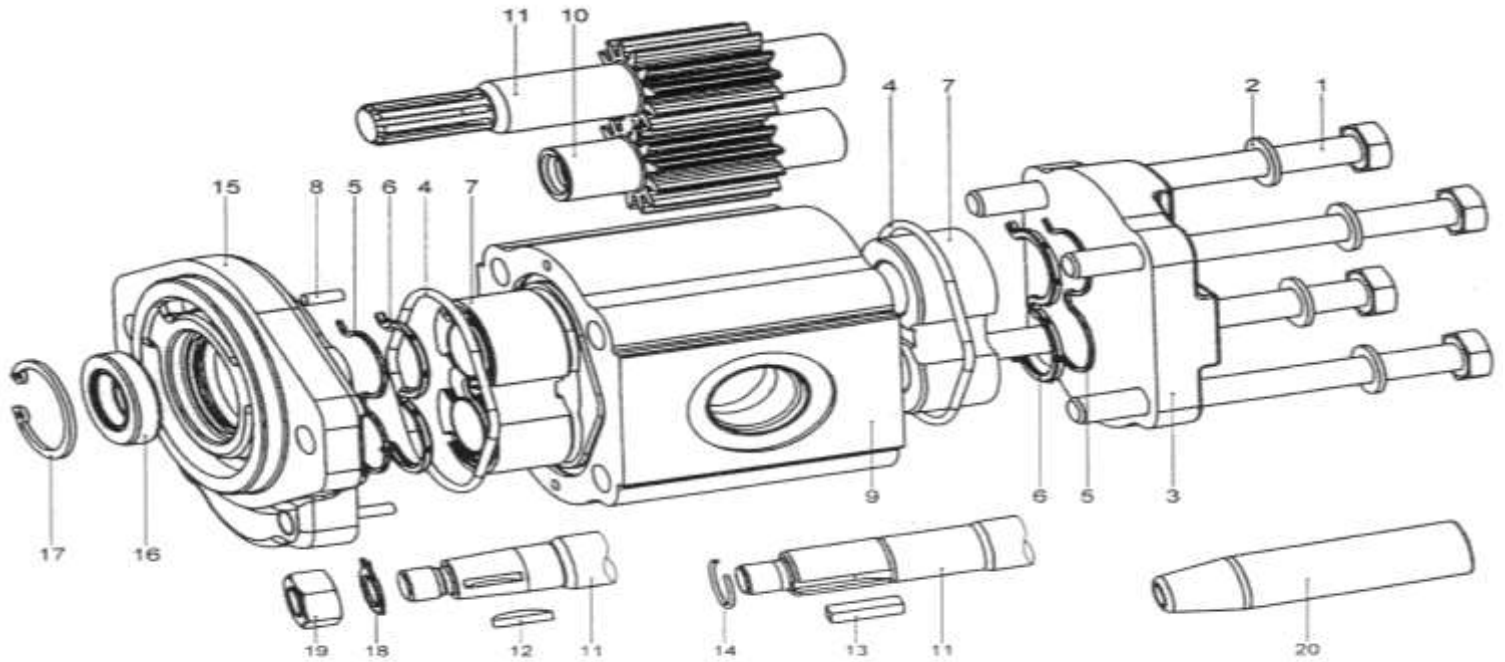
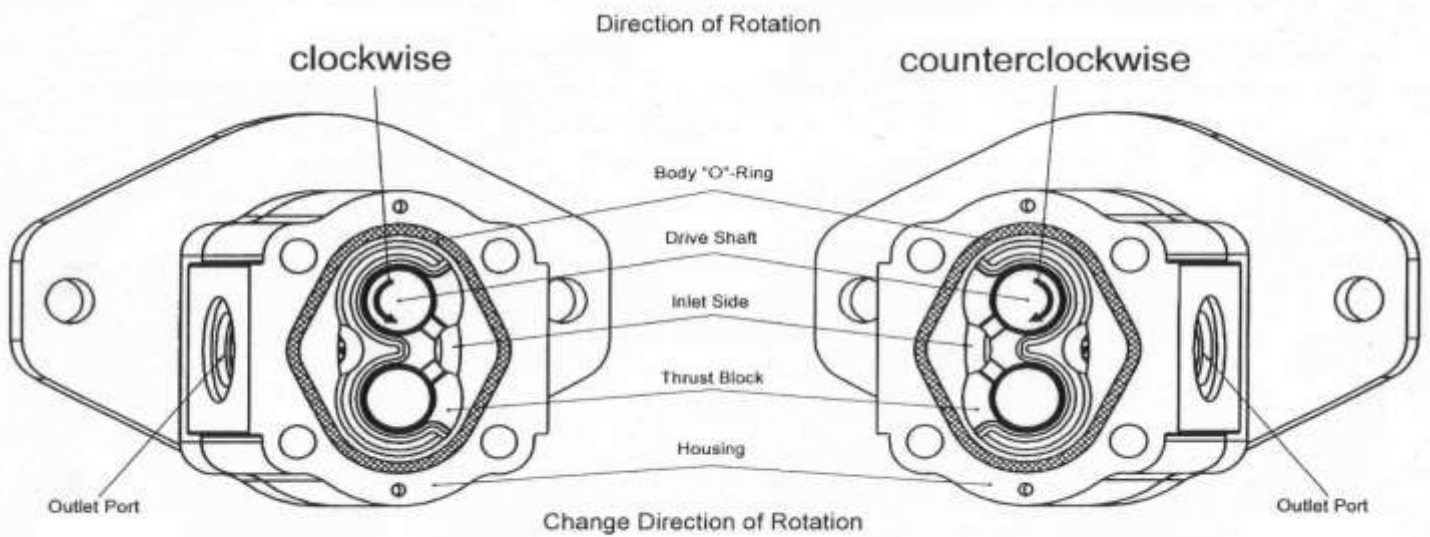
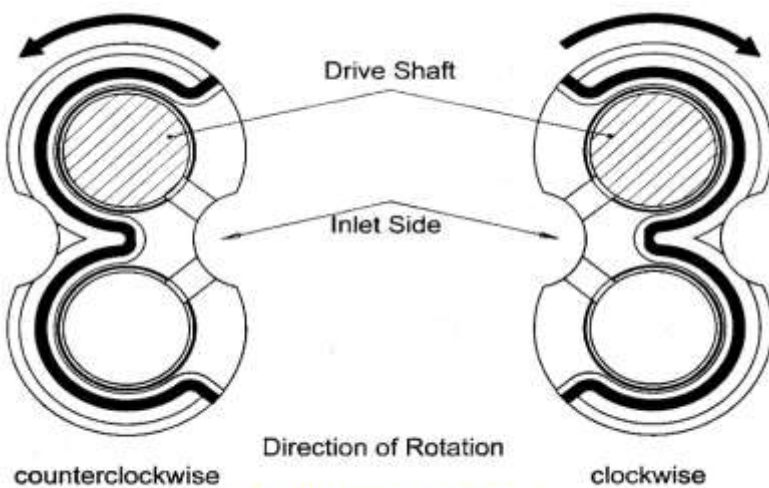

Fig.4



### Housing and Thrust Blocks turned 180°



### View from shaft end

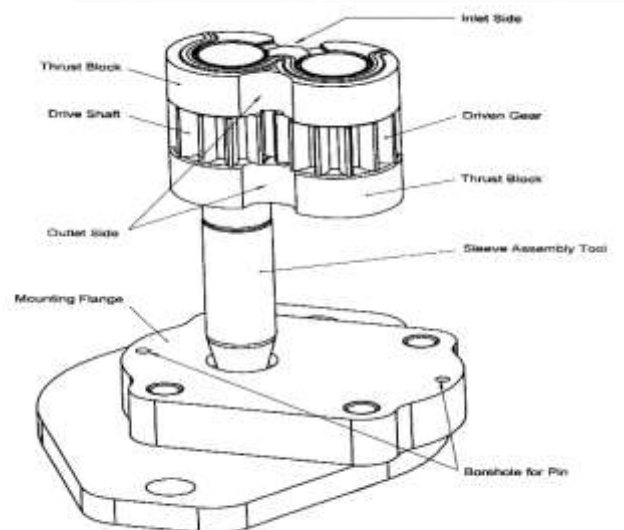

Fig. 2

# HYDRAULIC FORMULA CALCULATOR

## CYLINDER CALCULATIONS

**NOTE;** Put your amounts in where the **red figures** are and check out the answer where the **blue figures** are (click enter) !

CONVERSION CYLINDER; INCH TO METRIC	2" = 5.08 cm	3" = 7.62 cm	4" = 10.16 cm	5" = 12.7
CONVERSION SHAFT; INCH TO METRIC	1.06" = 2.70 cm	1.25" = 3.2 cm	1.50" = 3.80 cm	2" = 5.08 cm
	1-1/16" = 2.70 cm	1-1/4" = 3.2 cm	1-1/2" = 3.80 cm	2" = 5.08 cm

### CONVERSIONS INCH TO METRIC

TO BE USED WHEN CALCULATING INCH TO METRIC (cm) AND METRIC (cm) TO INCH

1	FORMULA				
	Metric / Inch	INCH	METRIC ANSWER	METRIC (cm)	INCH ANSWER
		8	20.32	15.24	6

### FORCE

TO BE USED WHEN CALCULATING THE FORCE OF A HYDRAULIC CYLINDER (LARGE PISTON AREA)

2	FORMULA	PRESSURE	CYLINDER DIAMETER	FORCE (tons)	FORCE (kg)
	tons	ENTER (Bar)	ENTER (cm)	(click enter) !	(click enter) !
		90	16	18.0864	18086.4

### SPEED

TO BE USED WHEN CALCULATING THE SPEED USING THE PISTON AREA

3	FORMULA	ENTER FLOW RATE (L/min)	ENTER PISTON DIAMETER (cm)	SPEED (m/s)	SPEED (sec/25 mm)
	m/s	12.1	12.7	0.015927845	1.569578306
				mm /sec	SECONDS / METER
				15.92784502	62.78313223

### SPEED

TO BE USED WHEN CALCULATING THE SPEED USING THE SHAFT AREA

4	FORMULA	ENTER FLOW RATE (L/min)	ENTER SHAFT DIAMETER (cm)	SPEED (m/s)	SPEED (sec/25 mm)
	m/s	12.1	5.08	0.099549031	0.251132529
				mm /sec	SECONDS / METER
				99.54903137	10.04530116

### TIME TAKEN TO DO FULL STROKE

TO BE USED WHEN CALCULATING THE TIME TAKEN FOR THE SHAFT TO TRAVEL OVER A SET DISTANCE

5	FORMULA	PISTON ( SIDE )	SHAFT ( SIDE )		
	Seconds	ENTER STROKE (mm)	ENTER STROKE (mm)		
		500	500		
		SECONDS TAKEN	SECONDS TAKEN		
		31.39156612	26.36891554		

### SWEPT VOLUME OF A CYLINDER ; PISTON SIDE

TO BE USED WHEN CALCULATING THE AMOUNT OF OIL NEEDED PISTON SIDE

6	FORMULA	ENTER CYL DIAMETER (cm)	ENTER STROKE (cm)	VOL OF PISTON SIDE (L)	
	liters	10.16	500	40.516048	

### SWEPT VOLUME OF A CYLINDER ; SHAFT SIDE

TO BE USED WHEN CALCULATING THE AMOUNT OF OIL NEEDED SHAFT SIDE

7	FORMULA	ENTER DIAM OF SHAFT (cm)	ENTER STROKE (cm)	VOLUME OF SHAFT	
	liters	6	500	14.139	

### MINIMUM TANK VOLUME SIZE ;

TO BE USED WHEN CALCULATING THE MINIMUM AMOUNT OF OIL NEEDED ON A DOUBLE ACTING CYLINDER

8	FORMULA	PISTON SIDE VOLUME	SHAFT SIDE VOLUME	TANK VOLUME	
	liters	40.516048	14.139	26.377048	

# HYDRAULIC FORMULA CALCULATOR

## PUMP CALCULATIONS

**NOTE;** Put your amounts where the **red figures** are and check out the answer where the **blue figures** are (click enter) !

### FLOW RATE

**TO BE USED WHEN CALCULATING THE FLOW RATE OF A HYDRAULIC PUMP**

1	FORMULA				
	L/min	ENTER cc/Rev	ENTER RPM	FLOW (L/min)	cc/min
		6	1450	8.7	8700
2	FORMULA				
	L/min	ENTER SPEED (m/s)	ENTER CYL DIAMETER (cm)	FLOW (L/min)	cc/min
		0.047717	5.08	5.799912787	5799.912787
3	FORMULA				
	L/min	ENTER POWER (KW)	ENTER PRESSURE (Mpa)	FLOW (L/min)	cc/min
		0.568	5	5.7936	5793.6

### POWER

**TO BE USED WHEN CALCULATING THE POWER REQUIRED TO DRIVE A HYDRAULIC PUMP**

4	FORMULA				
	kW	ENTER PRESSURE (bar)	ENTER FLOW RATE (L/min)	POWER (kW)	WATTS
		200	20	7.843137255	7843.137255
5	FORMULA				
	bar	ENTER PRESSURE (bar)	ENTER FLOW RATE (L/min)	POWER (kW)	WATTS
		198.9	20	7.8	7800
6	FORMULA				
	flow	ENTER PRESSURE (bar)	ENTER FLOW RATE (L/min)	POWER (kW)	WATTS
		200	19.89	7.8	

### GEAR PUMP CAPACITY

**TO BE USED WHEN CALCULATING THE APPROXIMATE FLOW RATE OF A GEAR PUMP**

	FORMULA				
7	CC/REV	A	B	D - d	CC/REV
		CENTRE TO CENTRE	GEAR WIDTH	GEAR OD - ID	
		44.3	32	19.8	38.40329434

### TORQUE

**TO BE USED WHEN CALCULATING THE TORQUE PRODUCED BY A HYDRAULIC MOTOR**

8	FORMULA				
	Nm	ENTER PRESSURE (Mpa)	ENTER DISPLACEMENT (cm <sup>3</sup> )	TORQUE (Nm)	Dm
		5	4	3.184713376	31.84713376
9	FORMULA				
	Nm	ENTER PRESSURE (Mpa)	ENTER FLOW RATE (L/min)	ENTER RPM	TORQUE (Nm)
		5	5.8	1450	3.18

### HOSE SIZING

**TO BE USED WHEN CALCULATING THE HOSE SIZE FOR SUCTION AND DELIVERY**

10	FORMULA				
	m/s	MAX. SPEED RATE	DISPLACEMENT	SUCTION PORT ID	
		(U/min)	(cm <sup>3</sup> )	(mm)	
		1450	25.0	19.0	*** Special note;
		Velocity (m/s)	→	2.13	METERS/SECOND

\*\*\* Special note; The maximum recommended flow rate for a gear pump is 2,5 m/s please do not exceed.

\*\*\* Special note; For delivery hose size, rule of thumb 25% smaller than suction hose

**PLEASE NOTE: ALL O.E.M. NAMES OR NUMBERS ARE FOR REFERENCE USE ONLY**

**TO BE USED AT YOUR OWN RISK BY; Dr Christine Edmonds of Milwaukee Wisconsin**

**PAGE X 6**

# PRESSURE CONVERSION CHART

1 kPa = 0,01 bar  
1 Mpa = 10,00 bar

1 kPa = 0,145 P.S.I.  
1 kg/cm<sup>2</sup> = 14,223 P.S.I.

Kg/cm<sup>2</sup> = 1,00 at  
1 P.S.I. = 6,895 kPa

kPa	Mpa	bar	kg/cm <sup>2</sup>	P.S.I.
5	0,005	0,05	0,05	0,73
10	0,01	0,1	0,10	1,45
25	0,025	0,25	0,25	3,63
50	0,05	0,5	0,51	7,25
75	0,075	0,75	0,76	10,88
100	0,1	1	1,02	14,5
200	0,2	2	2,04	29,0
300	0,3	3	3,06	43,5
400	0,4	4	4,08	58
500	0,5	5	5,10	72,5
600	0,6	6	6,12	87
700	0,7	7	7,14	102
800	0,8	8	8,16	116
900	0,9	9	9,18	131
1000	1	10	10,2	145
2000	2	20	20,4	290
3000	3	30	30,6	435
4000	4	40	40,8	580
5000	5	50	51,0	725
6000	6	60	61,2	870
7000	7	70	71,4	1015
8000	8	80	81,6	1160
9000	9	90	91,8	1305
10000	10	100	102	1450
11000	11	110	112	1595
12000	12	120	122	1740
13000	13	130	133	1885
14000	14	140	143	2030

kPa	Mpa	bar	kg/cm <sup>2</sup>	P.S.I.
15000	15	150	152	2175
16000	16	160	163	2320
17000	17	170	173	2465
18000	18	180	183	2610
19000	19	190	194	2755
20000	20	200	204	2900
21000	21	210	214	3045
22000	22	220	224	3190
23000	23	230	235	3335
24000	24	240	245	3480
25000	25	250	255	3625
26000	26	260	265	3770
27000	27	270	275	3915
28000	28	280	286	4060
29000	29	290	296	4205
30000	30	300	306	4350
31000	31	310	316	4495
32000	32	320	326	4640
33000	33	330	337	4785
34000	34	340	347	4930
35000	35	350	357	5075
36000	36	360	367	5220
37000	37	370	377	5365
38000	38	380	387	5510
39000	39	390	398	5655
40000	40	400	408	5800
41000	41	410	418	5945
42000	42	420	428	6090

kPa	Mpa	bar	kg/cm <sup>2</sup>	P.S.I.
43000	43	430	438	6235
44000	44	440	449	6380
45000	45	450	459	6525
46000	46	460	469	6670
47000	47	470	479	6815
48000	48	480	489	6960
49000	49	490	500	7105
50000	50	500	510	7250
51000	51	510	520	7395
52000	52	520	530	7540
53000	53	530	540	7685
54000	54	540	551	7830
55000	55	550	561	7975
56000	56	560	571	8120
57000	57	570	581	8265
58000	58	580	591	8410
59000	59	590	602	8555
60000	60	600	612	8700
61000	61	610	622	8845
62000	62	620	632	8990
63000	63	630	642	9135
64000	64	640	653	9280
65000	65	650	663	9425
66000	66	660	673	9570
67000	67	670	683	9715
68000	68	680	693	9860
69000	69	690	704	10005
70000	70	700	714	10150