

# CYLINDERS

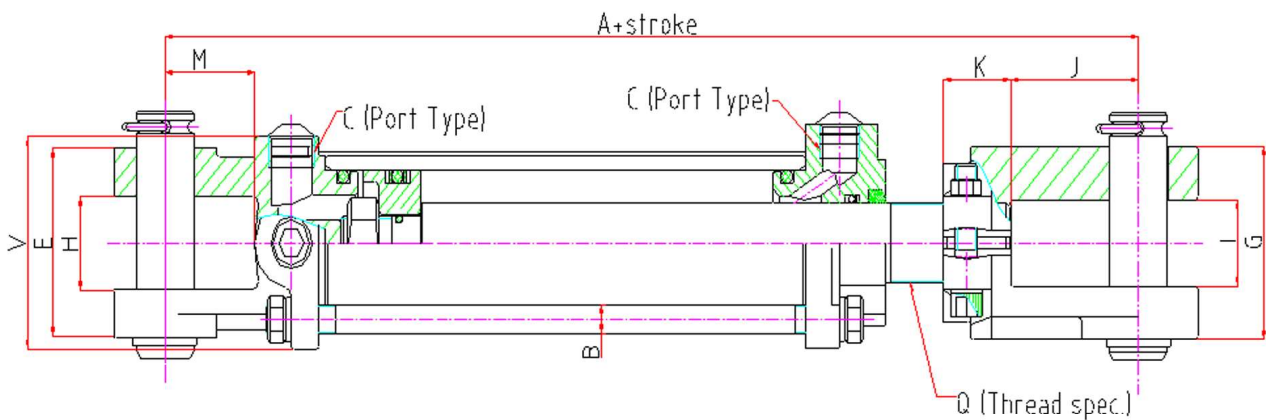

**HIRSCH HYDRAULIC SERVICES**



Unit 15, South Cape Industrial Park, 19 Leo Road, Diep River, Cape Town 7800  
P.O. Box 334, Bergvliet 7864

Tel: (021) 706 7573

Cell: 0827287796 / 0833737556

Email: [sales@hirschyd.co.za](mailto:sales@hirschyd.co.za)

[www.hirschhydraulics.co.za](http://www.hirschhydraulics.co.za)



# TAK - BOK

## 2" Bore Cylinders

### TIE ROD TYPE



Part Number	Bore x	Rod	Port	Clevis	Barrel	Shaft	Shaft	Barrel	Closed	Open	Force	Force	Swept	Swept	Wt.	RETAIL: 01-10-2022
	Stroke	Dia.	Size	Pin	Bore	stroke	O/D	Length	Centre	Centre	Rod	Piston	Volume	Volume	Kgs	
	inch	inch	Npt	Dia.	mm	mm	mm	mm	mm	mm	180 bar	180 bar	Rod	Piston	+/-	
											Tons	Tons	Litres	Litres		
81H-20006-106	2" x 6"	1-1/16"	3/8"	1"	50.8	152	26.9	210	413	565	2.37	3.53	0.22	0.31	7.1	
81H-20008-106	2" x 8"	1-1/16"	3/8"	1"	50.8	203	26.9	261	464	667	2.37	3.53	0.30	0.41	8	
81H-20008-106A	2" x 8"A	1-1/16"	3/8"	1"	50.8	203	26.9	261	514	717	2.37	3.53	0.30	0.41	8	
81H-20010-106	2" x 10"	1-1/16"	3/8"	1"	50.8	254	26.9	311	514	768	2.37	3.53	0.37	0.51	8.4	
81H-20012-106	2" x 12"	1-1/16"	3/8"	1"	50.8	305	26.9	362	565	870	2.37	3.53	0.44	0.62	9.1	
81H-20014-106	2" x 14"	1-1/16"	3/8"	1"	50.8	356	26.9	413	616	972	2.37	3.53	0.52	0.72	9.8	
81H-20016-106	2" x 16"	1-1/16"	3/8"	1"	50.8	406	26.9	464	667	1073	2.37	3.53	0.59	0.82	10.4	
81H-20018-106	2" x 18"	1-1/16"	3/8"	1"	50.8	457	26.9	515	718	1175	2.37	3.53	0.67	0.93	11.1	
81H-20020-106	2" x 20"	1-1/16"	3/8"	1"	50.8	508	26.9	565	768	1276	2.37	3.53	0.74	1.03	11.7	
81H-20024-106	2" x 24"	1-1/16"	3/8"	1"	50.8	610	26.9	667	870	1480	2.37	3.53	0.89	1.24	13	
81H-20028-106	2" x 28"	1-1/16"	3/8"	1"	50.8	711	26.9	769	972	1683	2.37	3.53	1.04	1.44	14.3	
81H-20030-106	2" x 30"	1-1/16"	3/8"	1"	50.8	762	26.9	819	1022	1784	2.37	3.53	1.11	1.54	15.1	
81H-20036-106	2" x 36"	1-1/16"	3/8"	1"	50.8	914	26.9	972	1175	2089	2.37	3.53	1.33	1.85	17.1	
81H-20048-106	2" x 48"	1-1/6"	3/8"	1"	50.8	1219	26.9	1277	1480	2699	2.37	3.53	1.78	2.47	21.4	
81H-20080-106	2" x 80"	1-1/16"	3/8"	1"	50.8	2032	26.9	2090	2292	4324	2.37	3.53	2.96	4.12	32.5	





# TAK - BOK

## 3" Bore Cylinders

### TIE ROD TYPE



Part Number	Bore x	Rod	Port	Clevis	Barrel	Shaft	Shaft	Barrel	Closed	Open	Force	Force	Swept	Swept	Wt.	RETAIL: 01-10-2022
	Stroke	Dia.	Size	Pin	Bore	stroke	O/D	Length	Centre	Centre	Rod	Piston	Volume	Volume	Kgs	
	inch	inch	Npt	Dia.	mm	mm	mm	mm	mm	mm	180 bar	180 bar	Rod	Piston	+/-	
											Tons	Tons	Litres	Litres		
81H-30006-125	3" x 6"	1-1/4"	1/2"	1"	76.2	152	31.75	210	413	565	6.74	8.16	0.57	0.69	10.1	
81H-30008-125	3" x 8"	1-1/4"	1/2"	1"	76.2	203	31.75	261	464	667	6.74	8.16	0.76	0.93	11	
81H-30008-150	3" x 8"	1-1/2"	1/2"	1"	76.2	203	38.1	261	464	667	6.11	8.16	0.69	0.93	12.1	
81H-30008-125A	3" x 8" A*	1-1/4"	1/2"	1"	76.2	203	31.75	261	514	717	6.74	8.16	0.76	0.93	11.3	
81H-30008-150A	3" x 8" A*	1-1/2"	1/2"	1"	76.2	203	38.1	261	514	717	6.11	8.16	0.69	0.93	12.4	
81H-30010-125	3" x 10"	1-1/4"	1/2"	1"	76.2	254	31.75	311	514	768	6.74	8.16	0.96	1.16	13.7	
81H-30010-150	3" x 10"	1-1/2"	1/2"	1"	76.2	254	38.1	311	514	768	6.11	8.16	0.87	1.16	15	
81H-30012-125	3" x 12"	1-1/4"	1/2"	1"	76.2	305	31.75	362	565	870	6.74	8.16	1.15	1.39	12.8	
81H-30012-150	3" x 12"	1-1/2"	1/2"	1"	76.2	305	38.1	362	565	870	6.11	8.16	1.04	1.39	14	
81H-30014-125	3" x 14"	1-1/4"	1/2"	1"	76.2	356	31.75	413	616	972	6.74	8.16	1.34	1.62	13.7	
81H-30014-150	3" x 14"	1-1/2"	1/2"	1"	76.2	356	38.1	413	616	972	6.11	8.16	1.22	1.62	15.1	
81H-30016-125	3" x 16"	1-1/4"	1/2"	1"	76.2	406	31.75	464	667	1073	6.74	8.16	1.53	1.85	14.8	
81H-30016-150	3" x 16"	1-1/2"	1/2"	1"	76.2	406	38.1	464	667	1073	6.11	8.16	1.39	1.85	16.3	
81H-30018-125	3" x 18"	1-1/4"	1/2"	1"	76.2	457	31.75	515	718	1175	6.74	8.16	1.72	2.08	15.8	
81H-30018-150	3" x 18"	1-1/2"	1/2"	1"	76.2	457	38.1	515	718	1175	6.11	8.16	1.56	2.08	17.4	
81H-30020-125	3" x 20"	1-1/4"	1/2"	1"	76.2	508	31.75	565	768	1276	6.74	8.16	1.91	2.32	16.8	
81H-30020-150	3" x 20"	1-1/2"	1/2"	1"	76.2	508	38.1	565	768	1276	6.11	8.16	1.74	2.32	18.5	
81H-30024-150	3" x 24"	1-1/2"	1/2"	1"	76.2	610	38.1	667	870	1480	6.11	8.16	2.09	2.78	21	
81H-30028-150	3" x 28"	1-1/2"	1/2"	1"	76.2	711	38.1	769	972	1683	6.11	8.16	2.43	3.24	23.6	
81H-30030-150	3" x 30"	1-1/2"	1/2"	1"	76.2	762	38.1	819	1022	1784	6.11	8.16	2.60	3.47	24.43	
81H-30036-150	3" x 36"	1-1/2"	1/2"	1"	76.2	914	38.1	972	1175	2089	6.11	8.16	3.12	4.17	28.2	
81H-30048-150	3" x 48"	1-1/2"	1/2"	1"	76.2	1219	38.1	1277	1480	2699	6.11	8.16	4.17	5.56	43.2	
81H-30080-150	3" x 80"	1-1/2"	1/2"	1"	76.2	2032	38.1	2090	2292	4324	6.11	8.16	6.95	9.26	52	
81H-30120-150	3" x 120"	1-1/2"	1/2"	1"	76.2	3048	38.1	3105	3308	6356	6.11	8.16	10.42	13.89	75	





# TAK - BOK

## 4" Bore Cylinders

### TIE ROD TYPE



Part Number	Bore x	Rod	Port	Clevis	Barrel	Shaft	Shaft	Barrel	Closed	Open	Force	Force	Swept	Swept	Wt.	RETAIL: 01-10-2022
	Stroke	Dia.	Size	Pin	Bore	stroke	O/D	Length	Centre	Centre	Rod	Piston	Volume	Volume	Kgs	
	inch	inch	Npt	Dia.	mm	mm	mm	mm	mm	mm	180 bar Tons	180 bar Tons	Rod Litres	Piston Litres	+/-	
81H-40008-200	4" x 8"	2"	1/2"	1"	101.6	203	50.8	261	464	667	10.76	14.41	1.23	1.64	18	
81H-40008-200A	4" x 8" A*	2"	1/2"	1"	101.6	203	50.8	261	514	717	10.76	14.41	1.23	1.64	18.4	
81H-40010-200	4" x 10"	2"	1/2"	1"	101.6	254	50.8	311	514	768	10.76	14.41	1.54	2.06	19.1	
81H-40012-200	4" x 12"	2"	1/2"	1"	101.6	305	50.8	362	565	870	10.76	14.41	1.85	2.47	20.6	
81H-40014-200	4" x 14"	2"	1/2"	1"	101.6	356	50.8	413	616	972	10.76	14.41	2.16	2.88	0.72	
81H-40016-200	4" x 16"	2"	1/2"	1"	101.6	406	50.8	464	667	1073	10.76	14.41	2.47	3.29	23.5	
81H-40018-200	4" x 18"	2"	1/2"	1"	101.6	457	50.8	515	718	1175	10.76	14.41	2.78	3.70	25.2	
81H-40020-200	4" x 20"	2"	1/2"	1"	101.6	508	50.8	565	768	1276	10.76	14.41	3.09	4.12	28.5	
81H-40024-200	4" x 24"	2"	1/2"	1"	101.6	610	50.8	667	870	1480	10.76	14.41	3.71	8.65	1.24	
81H-40028-200	4" x 28"	2"	1/2"	1"	101.6	711	50.8	769	972	1683	10.76	14.41	4.32	5.76	40.2	
81H-40030-200	4" x 30"	2"	1/2"	1"	101.6	762	50.8	819	1022	1784	10.76	14.41	4.63	6.17	42.2	
81H-40036-200	4" x 36"	2"	1/2"	1"	101.6	914	50.8	972	1175	2089	10.76	14.41	5.55	7.41	47.5	
81H-40048-200	4" x 48"	2"	1/2"	1"	101.6	1219	50.8	1277	1480	2699	10.76	14.41	7.41	9.88	56.2	
81H-40080-200	4" x 80"	2"	1/2"	1"	101.6	2032	50.8	2090	2292	4324	10.76	14.41	12.35	16.47	89.3	
81H-400120-200	4" x 120"	2"	1/2"	1"	101.6	3048	50.8	3105	3308	6356	10.76	14.41	18.52	24.70	128	



	<b>TAK - BOK</b>	
	<b>CYLINDER SPARES</b>	
	<b>TIE ROD TYPE</b>	

<u>Part Number</u>		<u>RETAIL:</u>
	<b><u>DESCRIPTION FOR ; 2" SPARES</u></b>	<b>01-10-2022</b>
81H-20-SKIT-NWO	2" SEAL KIT ; "O" RING DESIGN ; FOR SHAFT 1-1/16"	
81H-20-SKIT-NBU	2" SEAL KIT ; U SEAL DESIGN ; FOR SHAFT 1-1/16"	
81H-20-56891	2" ROD CLEVIS 1-1/16" OD SHAFT ; THREAD 1-1/16"- UNF	
81H-20-040001	2" ROD CLEVIS 1-1/16" OD SHAFT ; LOCKING SCREW TYPE 80" - 120" STROKE	
81H-A03-20A0C0	LOCKING SCREW FOR CLEVIS FOR 2" 3" 4"	
81H-N600001-2	LOCKING SCREW NYLON BLOCK FOR CLEVIS FOR 2" 3" 4"	
81H-20-59626	2" ROD CLEVIS PIN ; 1" OD	
81H-20-63512	2" R CLIP FOR PIN ; 1" OD	
81H-20-62538	2" HEAD ROD CAP ; "O" RING DESIGN ; FOR SHAFT 1-1/16"	
81H-20-62538NBU	2" HEAD ROD CAP ; U SEAL DESIGN ; FOR SHAFT 1-1/16"	
81H-20-59842	2" BASE BOTTOM CLEVIS 2 PORTS 3/8" NPT	
81H-20-59847	2" PISTON	
81H-20-P-NUT	2" PISTON NUT	
	<b><u>DESCRIPTION FOR ; 3" SPARES</u></b>	
81H-30-SKIT-NWO	3" SEAL KIT ; "O" RING DESIGN ; FOR SHAFT 1-1/4"	
81H-30-SKIT-NBO	3" SEAL KIT ; "O" RING DESIGN ; FOR SHAFT 1-1/2"	
81H-30-SKIT-NWU	3" SEAL KIT ; U SEAL DESIGN ; FOR SHAFT 1-1/4"	
81H-30-SKIT-NBU	3" SEAL KIT ; U SEAL DESIGN ; FOR SHAFT 1-1/2"	
81H-30-56892	3" ROD CLEVIS 1-1/4" & 1-1/2" OD SHAFT ; THREAD 1-1/4"- UNF; FOR BOTH SHAFT O/D	
81H-3040-040001	3" AND 4" ROD CLEVIS 1-1/2" & 2" OD SHAFT ; LOCKING SCREW 80" - 120" STROKE	
81H-A03-20A0C0	LOCKING SCREW FOR CLEVIS FOR 2" 3" 4"	
81H-N600001-2	LOCKING SCREW NYLON BLOCK FOR CLEVIS FOR 2" 3" 4"	
81H-30-59626	3" ROD CLEVIS PIN ; 1" OD	
81H-30-63512	3" R CLIP FOR PIN ; 1" OD	
81H-30-62541	3" HEAD ROD CAP ; "O" RING DESIGN ; FOR SHAFT 1-1/4"	
81H-30-62542	3" HEAD ROD CAP ; "O" RING DESIGN ; FOR SHAFT 1-12"	
81H-30-62541-NB	3" HEAD ROD CAP ; U SEAL DESIGN ; FOR SHAFT 1-1/4"	
81H-30-62542-NB	3" HEAD ROD CAP ; U SEAL DESIGN ; FOR SHAFT 1-1/2"	
81H-30-59844	3" BASE BOTTOM CLEVIS 2 PORTS 1/2" NPT	
81H-30-59849	3" PISTON	
81H-30-P-NUT	3" PISTON NUT	
	<b><u>DESCRIPTION FOR ; 4" SPARES</u></b>	
81H-40-SKIT-NWO	4" SEAL KIT ; "O" RING DESIGN ; FOR SHAFT 2"	
81H-40-SKIT-NBU	4" SEAL KIT ; U SEAL DESIGN ; FOR SHAFT 2"	
81H-40-56893	4" ROD CLEVIS 2" OD SHAFT ; THREAD 1-1/2"- UNF	
81H-3040-040001	3" AND 4" ROD CLEVIS 1-1/2" & 2" OD SHAFT ; LOCKING SCREW 80" - 120" STROKE	
81H-A03-20A0C0	LOCKING SCREW FOR CLEVIS FOR 2" 3" 4"	
81H-N600001-2	LOCKING SCREW NYLON BLOCK FOR CLEVIS FOR 2" 3" 4"	
81H-40-59626	4" ROD CLEVIS PIN ; 1" OD	
81H-40-63512	4" R CLIP FOR PIN ; 1" OD	
81H-40-62549	4" HEAD ROD CAP ; "O" RING DESIGN ; FOR SHAFT 2"	
81H-40-62549-NB	4" HEAD ROD CAP ; U SEAL DESIGN ; FOR SHAFT 2"	
81H-40-59846	4" BASE BOTTOM CLEVIS 2 PORTS 1/2" NPT	
81H-40-59851	4" PISTON	
81H-40-P-NUT	4" PISTON NUT	



# TIE ROD CYLINDER TECHNICAL

## HOW TO IDENTIFY TAK - BOK CYLINDERS

Barrel	Barrel	Barrel	*** How to work out closed centre	Cylinder
I/D	I/D	O/D	Measure barrel length in ? mm + 203 mm	Size
2"	50.8 mm	61 mm	Example ; TK 2008 -106 ( 261 + 203 ) = 464 mm C/C	2"
3"	76.2 mm	86 mm	Example ; TK 3008 -125 ( 261 + 203 ) = 464 mm C/C	3"
4"	101.6 mm	112 mm	Example ; TK 4008 -200 ( 261 + 203 ) = 464 mm C/C	4"

\*\*\* How to work out closed centre with no sample; use ( 260.4 mm ) + ( stroke mm ) = closed centre in mm

Barrel	Barrel	Barrel	*** How to work out open centre	Cylinder
I/D	I/D	O/D	Measure closed centre in ? mm + stroke in mm	Size
2"	50.8 mm	61 mm	Example ; TK 2008 -106 ( 464 + 203 ) = 667 mm C/C	2"
3"	76.2 mm	86 mm	Example ; TK 3008 -125 ( 464 + 203 ) = 667 mm C/C	3"
4"	101.6 mm	112 mm	Example ; TK 4008 -200 ( 464 + 203 ) = 667 mm C/C	4"

How to work out threads				
Bore Diameter	2" ( 50.8 mm )	3" ( 76.2 mm )	4" (101.6 mm)	
Shaft Diameter	1-1/16" (27mm)	1-1/4" (31.75mm)	1-1/2" (38.1mm)	2" (50.8mm)
Thread U N F	1-1/16" - 12 UNF	1-1/4" - 12 UNF		1-1/2" - 12 UNF
Ports N P T	3/8"	1/2"		1/2"

**NOTE: A\* - SHAFT STROKE FOR ASAE TYPE CYLINDERS, YOU MUST ADD AN EXTRA 50.8 mm OR 2"**

## BUCKLING LOADS FOR TIE ROD CYLINDERS

### 2" CYLINDER

BUCKLING LOADS		STROKE		
Bore 2"	Shaft 1-1/16	6" TO 18"	20" TO 24"	28" TO 36"
		Stable Region Safety 3:1	Safety 2:1	Safety 1:1

### 3" CYLINDER

BUCKLING LOADS		STROKE		
Bore 3"	Shaft 1-1/4"	6" TO 16"	18" TO 20"	24" TO 36"
Bore 3"	Shaft 1-1/2"	6" TO 24"	28" TO 36"	
		Stable Region Safety 3:1	Safety 2:1	Safety 1:1

### 4" CYLINDER

BUCKLING LOADS		STROKE		
Bore 4"	Shaft 2"	8" TO 36"		
		Stable Region Safety 3:1	Safety 2:1	Safety 1:1

## CYLINDER DIMENSIONS

BORE	A***	B	C	E & G	H & I	J	M	Q	V
2"	10.25"	0.188"	3/8"	2.441"	1.125"	2.125"	2"	1-1/16"	2.874"
50.8 mm	260.4 mm	4.8 mm	NPT	62 mm	29 mm	54 mm	50.8 mm	UNF	73 mm
3"	10.25"	0.188"	1/2"	2.717"	1.125"	2.125"	2"	1-1/4"	3.78"
76.2 mm	260.4 mm	4.8 mm	NPT	69 mm	29 mm	54 mm	50.8 mm	UNF	96mm
4"	10.25"	0.25"	1/2"	2.717"	1.125"	2.125"	2.118"	1-1/2"	5.039"
101.6 mm	260.4 mm	6.35 mm	NPT	69 mm	29 mm	54 mm	53.8 mm	UNF	128 mm

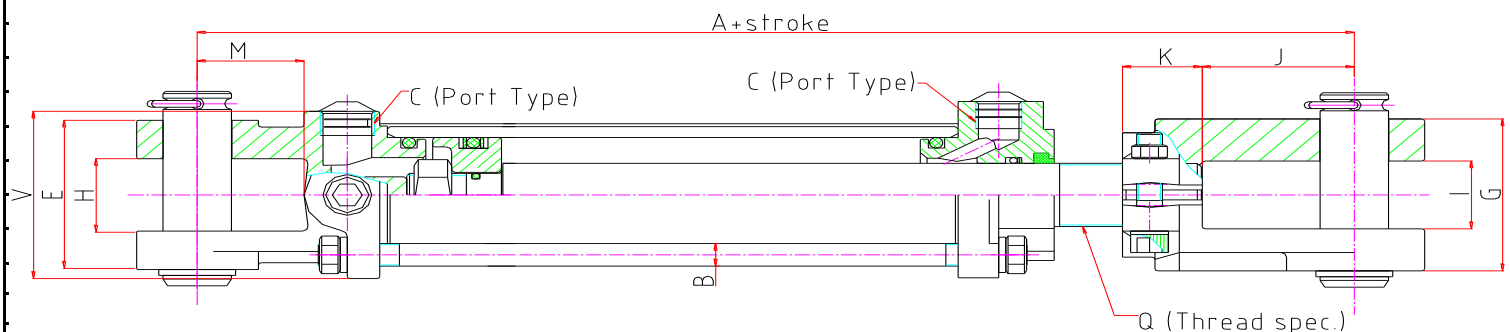

# TAK - BOK

## 2" Bore Cylinders

### WELDED TYPE

Part Number	Bore x	Rod	Port	Clevis	Barrel	Shaft	Shaft	Barrel	Closed	Open	Force	Force	Swept	Swept	Wt.	RETAIL: 01-01-2023
	Stroke	Dia.	Size	Pin	Bore	stroke	O/D	Length	Centre	Centre	Rod	Piston	Volume	Volume	Kgs	
	inch	inch	Bsp	Dia.	mm	mm	mm	mm	mm	mm	250 bar	250 bar	Rod	Piston	+/-	
											Tons	Tons	Litres	Litres		
81H-WC20006-113	2" x 6"	1-1/8"	3/8"	1"	50.8	152	28.7	242	413	565	3.4	5	0.21	0.31	6.1	
81H-WC20008-113	2" x 8"	1-1/8"	3/8"	1"	50.8	203	28.7	293	464	667	3.4	5	0.28	0.41	6.7	
81H-WC20010-113	2" x 10"	1-1/8"	3/8"	1"	50.8	254	28.7	344	514	768	3.4	5	0.35	0.51	7.3	
81H-WC20012-113	2" x 12"	1-1/8"	3/8"	1"	50.8	305	28.7	395	565	870	3.4	5	0.42	0.62	7.9	
81H-WC20014-113	2" x 14"	1-1/8"	3/8"	1"	50.8	356	28.7	446	616	972	3.4	5	0.49	0.72	8.5	
81H-WC20016-113	2" x 16"	1-1/8"	3/8"	1"	50.8	406	28.7	496	667	1073	3.4	5	0.56	0.82	9.1	
81H-WC20018-113	2" x 18"	1-1/8"	3/8"	1"	50.8	457	28.7	547	718	1175	3.4	5	0.63	0.93	9.7	
81H-WC20020-113	2" x 20"	1-1/8"	3/8"	1"	50.8	508	28.7	598	768	1276	3.4	5	0.70	1.03	10.3	
81H-WC20024-113	2" x 24"	1-1/8"	3/8"	1"	50.8	610	28.7	700	870	1480	3.4	5	0.84	1.24	11.4	
81H-WC20030-113	2" x 30"	1-1/8"	3/8"	1"	50.8	762	28.7	852	1022	1784	3.4	5	1.05	1.54	13.2	
81H-WC20036-113	2" x 36"	1-1/8"	3/8"	1"	50.8	914	28.7	1004	1175	2089	3.4	5	1.26	1.85	14.9	



Part Number	<div style="text-align: center;"> <b>TAK - BOK</b>  <b>3" Bore Cylinders</b>  <b>WELDED TYPE</b> </div>															<div style="text-align: center;"> <b>RETAIL:</b>  <b>01-01-2023</b> </div>
	Bore x Stroke	Rod Dia.	Port Size	Clevis Pin	Barrel Bore	Shaft stroke	Shaft O/D	Barrel Length	Closed Centre	Open Centre	Force Rod	Force Piston	Swept Volume Rod	Swept Volume Piston	Wt. Kgs	
	inch	inch	Bsp	Dia.	mm	mm	mm	mm	mm	mm	mm	250 bar	250 bar	Litres	Litres	
81H-WC30006-150	3" x 6"	1-1/2"	1/2"	1"	76.2	152	38.1	252	413	565	8.5	11.5	0.52	0.69	11.1	
81H-WC30008-150	3" x 8"	1-1/2"	1/2"	1"	76.2	203	38.1	303	464	667	8.5	11.5	0.69	0.93	12.2	
81H-WC30008150A	3" x 8" A*	1-1/2"	1/2"	1"	76.2	203	38.1	303	514	717	8.5	11.5	0.69	0.93	12.7	
81H-WC30010-150	3" x 10"	1-1/2"	1/2"	1"	76.2	254	38.1	354	514	768	8.5	11.5	0.87	1.16	13.4	
81H-WC30012-150	3" x 12"	1-1/2"	1/2"	1"	76.2	305	38.1	405	565	870	8.5	11.5	1.04	1.39	14.5	
81H-WC30014-150	3" x 14"	1-1/2"	1/2"	1"	76.2	356	38.1	456	616	972	8.5	11.5	1.22	1.62	15.6	
81H-WC30016-150	3" x 16"	1-1/2"	1/2"	1"	76.2	406	38.1	506	667	1073	8.5	11.5	1.39	1.85	16.6	
81H-WC30018-150	3" x 18"	1-1/2"	1/2"	1"	76.2	457	38.1	557	718	1175	8.5	11.5	1.56	2.08	17.7	
81H-WC30020-150	3" x 20"	1-1/2"	1/2"	1"	76.2	508	38.1	608	768	1276	8.5	11.5	1.74	2.32	18.8	
81H-WC30024-150	3" x 24"	1-1/2"	1/2"	1"	76.2	610	38.1	710	870	1480	8.5	11.5	2.09	2.78	21.1	
81H-WC30028-150	3" x 28"	1-1/2"	1/2"	1"	76.2	711	38.1	811	972	1683	8.5	11.5	2.43	3.24	23.1	
81H-WC30030-150	3" x 30"	1-1/2"	1/2"	1"	76.2	762	38.1	862	1022	1784	8.5	11.5	2.60	3.47	24.3	
81H-WC30036-150	3" x 36"	1-1/2"	1/2"	1"	76.2	914	38.1	1014	1175	2089	8.5	11.5	3.12	4.17	27.6	
81H-WC30048-150	3" x 48"	1-1/2"	1/2"	1"	76.2	1219	38.1	1319	1480	2699	8.5	11.5	4.17	5.56	34.1	
81H-WC30120-150	3" x 120"	1-1/2"	1/2"	1"	76.2	3048	38.1	3148	3308	6356	8.5	11.5	10.42	13.89	73.8	







**TAK - BOK**  
**CYLINDER SPARES**  
**WELDED TYPE**



Part Number	DESCRIPTION FOR ; 2" SPARES	RETAIL:
		01-01-2023
81H-20-SKIT-W	2" SEAL KIT	
81H-20-CLV2001	MALE ROD END CLEVIS 2"	
81H-20-WBC2003	MALE BASE BOTTOM CLEVIS 2"	



Part Number	DESCRIPTION FOR ; 3" SPARES	RETAIL:
81H-30-SKIT-W	3" SEAL KIT	
81H-30-CLV3001	MALE ROD END CLEVIS 3"	
81H-30-WBC3002	MALE BASE BOTTOM CLEVIS 3"	



# WELDED CYLINDER TECHNICAL

## CYLINDER DIMENSIONS

PART NUMBER	STROKE	RETRACTED	PART NUMBER	STROKE	RETRACTED
81H-WC20006-113	152.4 (6.00")	412.75 (16.25")	81H-WC20018-113	457.2 (18.00")	717.55 (28.25")
81H-WC20008-113	203.2 (8.00")	463.55 (18.25")	81H-WC20020-113	508.0 (20.00")	768.35 (30.25")
81H-WC20012-113	304.8 (12.00")	565.15 (22.25")	81H-WC20024-113	609.6 (24.00")	869.95 (34.25")
81H-WC20014-113	355.6 (14.00")	615.95 (24.25")	81H-WC20030-113	762.0 (30.00")	1022.35 (40.25")
81H-WC20016-113	406.4 (16.00")	666.75 (26.25")	81H-WC20036-113	914.4 (36.00")	1174.75 (46.25")

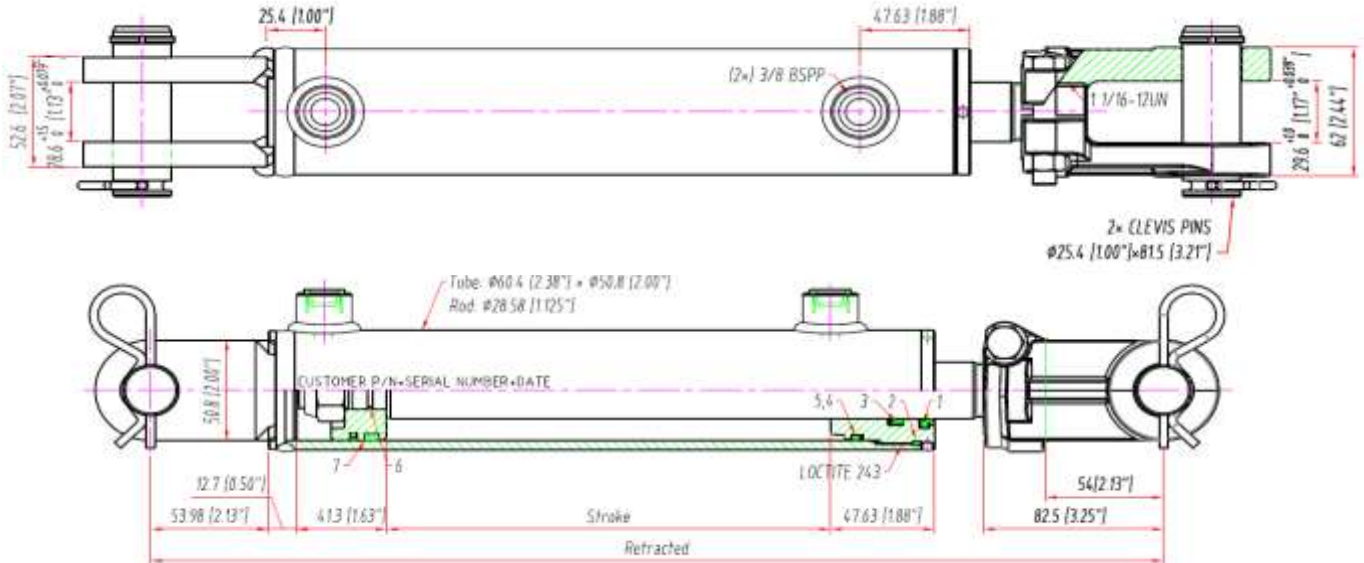

## CYLINDER DIMENSIONS

PART NUMBER	STROKE	RETRACTED	PART NUMBER	STROKE	RETRACTED
81H-WC30006-150	152.4 (6.00")	412.75 (16.25")	81H-WC30020-150	508.0 (20.00")	768.35 (30.25")
81H-WC30008-150	203.2 (8.00")	463.55 (18.25")	81H-WC30024-150	609.6 (24.00")	869.95 (34.25")
81H-WC30008-150A	203.2 (8.00")	514.35 (20.25")	81H-WC30028-150	711.2 (28.00")	971.55 (38.25")
81H-WC30010-150	355.6 (14.00")	615.95 (24.25")	81H-WC30030-150	762.0 (30.00")	1022.35 (40.25")
81H-WC30012-150	304.8 (12.00")	565.15 (22.25")	81H-WC30036-150	914.4 (36.00")	1174.75 (46.25")
81H-WC30014-150	355.6 (14.00")	615.95 (24.25")	81H-WC30048-150	1219.2 (48.00")	1479.55 (58.25")
81H-WC30016-150	406.4 (16.00")	666.75 (26.25")	81H-WC30120-150	3048.0 (120.00")	3308.35 (130.25")
81H-WC30018-150	457.2 (18.00")	717.55 (28.25")			

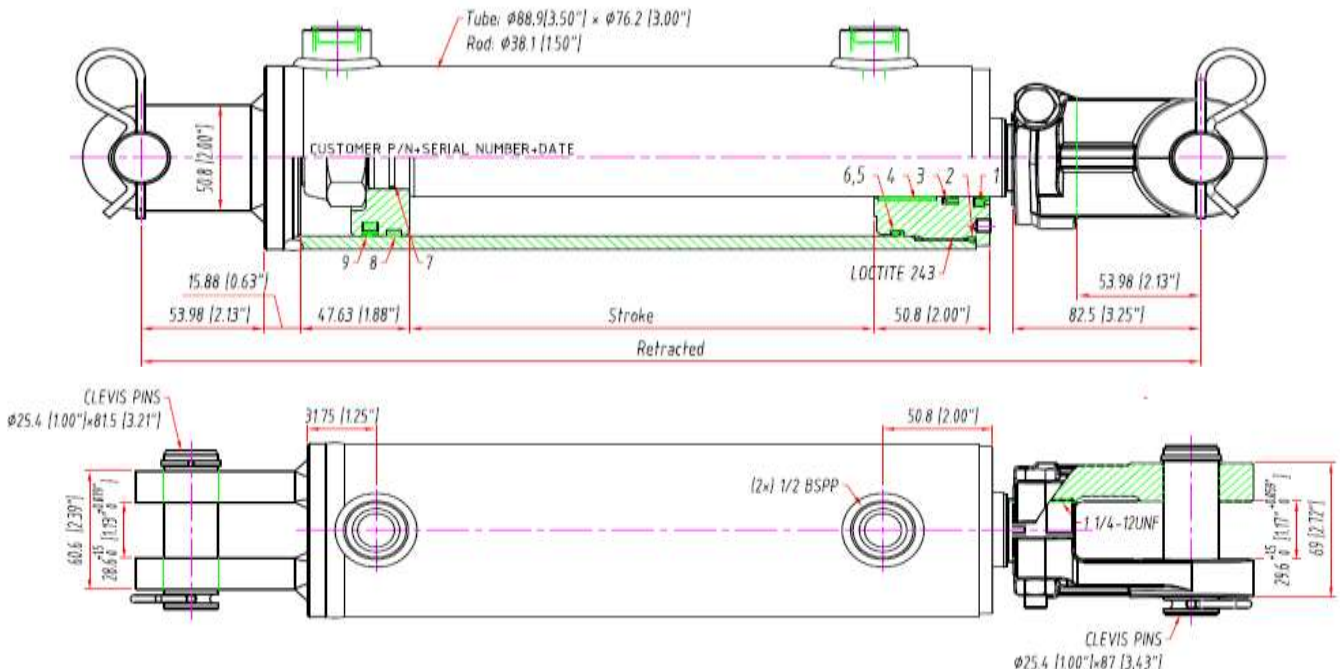

**CBT SERIES HI / LOW PUMPS**

72H-C-6-3-2-1	PUMP CBT 6.3 cc - 2.1 cc
72H-C-10-9-3-6	PUMP CBT 10.9 cc - 3.6 cc
72H-C-22-9-7-6	PUMP CBT 22.9 cc - 7.6 cc

**TECHNICAL SPECS ON CBT SERIES 210 Bar**

SHAFT	SPIGOT	MOUNT	SUCTION	PRESSURE	ROTATION
1/2" P/Key	45.25mm	4 BOLT 50.08 X 50.08	25.4mm PIPE	1/2" NPT	C/W
5/8" P/KEY	3-1/4"	2 BOLT	1" NPT	3/4" NPT	C/W

**LOG SPLITTER VALVE**

72H-LS-TW-20F	LS-TW LOG SPLITTER VALVE HAND OPERATED ONE WAY WITH DETENT PRESSURE RELEASE
---------------	---

**LOG SPLITTER CYLINDER**

82H-TKLOG518	LOG SPLITTER CYLINDER 125 X 810 X 1267 X 75
--------------	---

**SPECS**

LOG SPLITTER CYLINDER 25 TONS @ 210 BAR PISTON SIDE
BORE 125mm
CLOSED CENTRE 810mm
OPEN CENTRE 1267mm
STROKE 457mm
SHAFT OD 75mm



## HYDRAULIC WORKSHOP FORMULAE

### CYLINDER FORCE ; IN KILOGRAMS (KG)

$$\text{Kg} = \text{AREA} \times \text{PRESSURE} = \text{DIAMETER (cm)} \times \text{DIAMETER (cm)} \times \text{PRESSURE (bar)} \times 3.14 \div 4$$

$$\text{Kg} = 10.1 \text{ cm} \times 10.1 \text{ cm} \times 180 \text{ Bar} \times 3.14 \div 4 = 14414 \text{ Kg}$$

$$\text{tons} = \text{Kg} \div 1000$$

$$14414 \text{ Kg} \div 1000 = 14.41 \text{ tons}$$

### CYLINDER CAPACITY FLOW RATE ; IN LITRES PER MINUTE ( L/min )

$$\text{L/min} = \text{AREA} \times \text{SPEED} = \text{DIAMETER (cm)} \times \text{DIAMETER (cm)} \times \text{SPEED (m/s)} \times 4.71$$

$$\text{L/min} = 10.1 \text{ cm} \times 10.1 \text{ cm} \times .02 \text{ m/s} \times 4.71 = 9 \text{ L/min}$$

### CYLINDER SHAFT SPEED ; IN MILLIMETERS PER SEC (M/S)

$$\text{m/s} = \text{FLOW RATE} \div \text{AREA} = \text{FLOW RATE ( L/min)} \div \text{DIAMETER (cm)} \div \text{DIAMETER (cm)} \times 0.21$$

$$\text{m/s} = 9 \text{ L/min} \div 10.1 \text{ cm} \div 10.1 \text{ cm} \times .21 = .02 \text{ m/s} = 20 \text{ mm/s}$$

### CYLINDER STROKE TIME ; IN SECONDS PER STROKE

$$\text{sec} = \text{STROKE LENGTH (cm)} \div \text{SPEED (m/s)} \div 100$$

$$\text{sec} = 10 \text{ cm} \div .02 \text{ m/s} \div 100 = 5 \text{ sec}$$

### PUMP FLOW : IN LITRES PER MINUTE ( L/min )

$$\text{L/min} = \text{cc / Rev} \times \text{RPM} \div 1000$$

$$\text{L/min} = 14 \text{ cc/Rev} \times 1450 \text{ RPM} \div 1000 = 20.3 \text{ L/min}$$

### PUMP INPUT POWER ; IN KILOWATTS ( MILLIMETERS )

$$\text{Kw} = \text{FLOW} \times \text{PRESSURE} \div 600 \div 0.85$$

$$\text{Kw} = 20 \text{ LITRES} \times 180 \text{ Bar} \div 600 \div 0.85 = 7 \text{ KW ( KILOWATT )}$$

### MOTOR TORQUE ; IN NEWTON METER (Nm)

$$\text{Nm} = \text{PRESSURE (MPa)} \times \text{FLOW (L/min)} \times 159 \div \text{RPM}$$

$$\text{Nm} = 21 \text{ MPa} \times 9 \text{ L/min} \times 159 \div 1450 \text{ RPM} = 20.72 \text{ Nm}$$

### MOTOR TORQUE ; IN NEWTON METER (Nm)

$$\text{Nm} = \text{PRESSURE (MPa)} \times \text{DISPLACEMENT (cm X cm)} \div 6.28$$

$$\text{Nm} = 21 \text{ MPa} \times 10 \text{ cm}^2 \div 6.28 = 33.44 \text{ Nm}$$

### PUMP SHAFT PL FACTOR ; IN TORQUE NEWTON METER ( Nm )

$$\text{Nm} = \text{cc / Rev} \times \text{bar} / 57.2 = \text{Nm ( NEWTON METER )}$$

$$\text{Nm} = 14 \text{ cc / Rev} \times 140 \text{ bar} \div 57.2 = 34 \text{ Nm}$$

### CONVERSION FACTORS

$$1 \text{ Kw} = 1.34 \text{ HP}$$

$$1 \text{ HP} = 0.75 \text{ Kw}$$

$$1 \text{ Kw} = 1000 \text{ Watts}$$

$$1000 \text{ Kg} = 1 \text{ TON METRIC}$$

$$1 \text{ KILOGRAM} = 2.2 \text{ Lbs}$$

$$1 \text{ NEWTON METER ( nm )} = 8.9 \text{ in-Lbs.}$$

$$1 \text{ NEWTON METER ( nm )} = 0.74 \text{ ft-Lbs.}$$

$$10 \text{ NEWTON METERS ( nm )} = 1 \text{ Dnm}$$

$$1 \text{ US Gal} = 3.79 \text{ Litre}$$

$$1 \text{ Imp. Gallon} = 4.5 \text{ LITRE}$$

$$1 \text{ cu Inch} = 16.4 \text{ cc}$$

$$1 \text{ Inch} = 25.4 \text{ mm}$$

$$1 \text{ METER} = 39.4 \text{ Inch}$$

$$0.01 \text{ mm} = 4 \text{ thousands of an Inch}$$

$$1 \text{ bar} = 14.5 \text{ PSI}$$

$$1 \text{ MPA} = 10 \text{ bar}$$

$$1 \text{ bar} = 100 \text{ Kpa}$$

# HYDRAULIC FORMULA CALCULATOR

## CYLINDER CALCULATIONS

**NOTE;** Put your amounts in where the **red figures** are and check out the answer where the **blue figures** are (click enter) !

CONVERSION CYLINDER; INCH TO METRIC	2" = 5.08 cm	3" = 7.62 cm	4" = 10.16 cm	5" = 12.7
CONVERSION SHAFT; INCH TO METRIC	1.06" = 2.70 cm	1.25" = 3.2 cm	1.50" = 3.80 cm	2" = 5.08 cm
	1-1/16" = 2.70 cm	1-1/4" = 3.2 cm	1-1/2" = 3.80 cm	2" = 5.08 cm

### CONVERSIONS INCH TO METRIC

TO BE USED WHEN CALCULATING INCH TO METRIC (cm) AND METRIC (cm) TO INCH

1	FORMULA				
	Metric / Inch	INCH	METRIC ANSWER	METRIC (cm)	INCH ANSWER
		8	20.32	15.24	6

### FORCE

TO BE USED WHEN CALCULATING THE FORCE OF A HYDRAULIC CYLINDER (LARGE PISTON AREA)

2	FORMULA	PRESSURE	CYLINDER DIAMETER	FORCE (tons)	FORCE (kg)
	tons	ENTER (Bar)	ENTER (cm)	(click enter) !	(click enter) !
		90	16	18.0864	18086.4

### SPEED

TO BE USED WHEN CALCULATING THE SPEED USING THE PISTON AREA

3	FORMULA	ENTER FLOW RATE (L/min)	ENTER PISTON DIAMETER (cm)	SPEED (m/s)	SPEED (sec/25 mm)
	m/s	12.1	12.7	0.015927845	1.569578306
				mm /sec	SECONDS / METER
				15.92784502	62.78313223

### SPEED

TO BE USED WHEN CALCULATING THE SPEED USING THE SHAFT AREA

4	FORMULA	ENTER FLOW RATE (L/min)	ENTER SHAFT DIAMETER (cm)	SPEED (m/s)	SPEED (sec/25 mm)
	m/s	12.1	5.08	0.099549031	0.251132529
				mm /sec	SECONDS / METER
				99.54903137	10.04530116

### TIME TAKEN TO DO FULL STROKE

TO BE USED WHEN CALCULATING THE TIME TAKEN FOR THE SHAFT TO TRAVEL OVER A SET DISTANCE

5	FORMULA	PISTON ( SIDE )	SHAFT ( SIDE )		
	Seconds	ENTER STROKE (mm)	ENTER STROKE (mm)		
		500	500		
		SECONDS TAKEN	SECONDS TAKEN		
		31.39156612	26.36891554		

### SWEPT VOLUME OF A CYLINDER ; PISTON SIDE

TO BE USED WHEN CALCULATING THE AMOUNT OF OIL NEEDED PISTON SIDE

6	FORMULA	ENTER CYL DIAMETER (cm)	ENTER STROKE (cm)	VOL OF PISTON SIDE (L)	
	liters	10.16	500	40.516048	

### SWEPT VOLUME OF A CYLINDER ; SHAFT SIDE

TO BE USED WHEN CALCULATING THE AMOUNT OF OIL NEEDED SHAFT SIDE

7	FORMULA	ENTER DIAM OF SHAFT (cm)	ENTER STROKE (cm)	VOLUME OF SHAFT	
	liters	6	500	14.139	

### MINIMUM TANK VOLUME SIZE ;

TO BE USED WHEN CALCULATING THE MINIMUM AMOUNT OF OIL NEEDED ON A DOUBLE ACTING CYLINDER

8	FORMULA	PISTON SIDE VOLUME	SHAFT SIDE VOLUME	TANK VOLUME	
	liters	40.516048	14.139	26.377048	